

Dorat AL-Tal Co.
For Contracting



شركة درة التل
للمقاولات

PRECAST CONCRETE FACTORY
ISO Certified: ISO 9001:2015

1. Manhole
2. Culvert
3. Mini-Manhole
4. Handhole
5. Catch Basin
6. Sewer/Storm Manhole
7. Cabinet Base Foundation
8. Marker Post
9. Steel Pole Foundation
10. Safety (concrete barricade)

***** WE ARE ACCEPTING ALSO SPECIAL TYPE AS PER CLIENT SPECS.*****



PO.BOX 10700, RIYADH 11443
KINGDOM OF SAUDI ARABIA
TEL NO. 011 – 4660408
FAX NO. 011 – 4661016
Mobile NO. +966 552205844
Email : dorat@dorataltal.com
sales2@dorataltal.com

ص. ب. 10700, الرياض 11443
المملكة العربية السعودية
رقم هاتف 011 - 4660408
رقم فاكس 011 - 4661016
رقم جوال +966 552205844
Email : dorat@dorataltal.com
sales2@dorataltal.com



CONTENTS

- ✚ GENERAL INFORMATION

- ✚ Introduction

- ✚ Strategy

- ✚ Organizational Chart

- ✚ Technical Data Sheets

- ✚ Company Business Documents (Attachment #1)

- ✚ Approval Certificates from Vendor/Clients (Attachment #2)

- ✚ Location Maps (Attachment #3)

- ✚ Factories Layout (Attachment #4)

- ✚ QC/Safety Manual (Attachment #5)

- ✚ List of Projects (Attachment #6)

- ✚ Standard Drawings of Clients (Attachment #7)





GENERAL INFORMATION

Company Name: DORAT ALTAL PRECAST FACTORY
A Division of Dorat Al Tal Company
Dorat Al-Tal Company (for PRECAST, OSP & Electrical Works)

Premises: RIYADH, KINGDOM OF SAUDI ARABIA

Mailing Address: P.O. BOX 16829, RIYADH 11474
KINGDOM OF SAUDI ARABIA

Telephone: (00966 11) 466 0408

Fax: (00966 11) 466 1016

E-Mail: dorat@dorataltal.com
zakmaatouk@gmail.com

Contact Person: *Eng'r: Zakaria R. Maatouk*
General Manager
0552857000

Ahmad Al Mostafa

Factory Manager
(Sulay Factory)
0550931633

Ahmed Jamous

Sales Manager
(Head Office)
0504402963



A Branch of Mas Group of Companies



Introduction:

Dorat Al-Tal **Precast** factory is another division of Dorat Al-Tal Company in which the main work is specialized in productions of different types of precast manholes, mini-manholes, handholes, cabinet bases, lighting pole foundations, marker post, new-jersey concrete barricades and others.

Dorat Al-Tal precast factory is an approved supplier of Saudi Telecom Company(STC), Integrated Telecom Company(ITC), Mobily, Ministry of Interior(MOI), Ministry of Housing(MOH), GPT-National Guard, MODON, and has supplied also per project basis to Saudi Electricity Company(SEC)/National Grid, Saudi-ARAMCO, Saline Water Conversion Corporation(SWCC), National Water Corporation(NWC) and other companies with different types of telecom & electrical manholes/handholes, cabinet bases, lighting pole foundations, marker post and new jersey concrete barricades as per their specifications.

Dorat Al-Tal has international certifications from ISO, ISO 9001:2015.

Dorat Al-Tal precast factory is located in Sulay area, Al Kharj road.

We guarantee our customers the deliveries on time and supply them the best quality of precast products as per their specifications.

Thank you very much for your acceptance and we looking forward for mutual future relationship between us and your esteemed company.

Best Regards,

ZAKARIA R. MAATOUK
General Manager



A Branch of Mas Group of Companies



✚ Strategy:

✓ Vision statement

Dorat Al-Tal aims always to exceed the client's expectations.

✓ Mission statement

Dorat Al-Tal committed to supply the best quality of precast products in the market.

Company Profile



A Branch of Mas Group of Companies

Dorat AL-Tal Co.
For Contracting

C.R. 1010223989



شركة درة التل
للمقاولات

س.ت ١٠١٠٢٢٣٩٨٩

✚ Organizational Chart:

See attached...

Company Profile



A Branch of Mas Group of Companies

المملكة العربية السعودية - ص.ب ١٦٨٧٤ - ت: ٤٦٦٠٤٠٨ - ف: ٤٦٦١٠١٦ بريد الكتروني: dorat@dorataltal.com
Kingdom of Saudi Arabia, P.O. Box 16829, Riyadh 11474 Tel.: 4660408, Fax: 4661016, Email: dorat@dorataltal.com

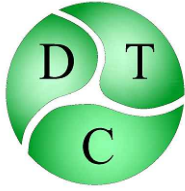

Dorat AL-Tal Co.
For Contracting

DORAT AL-TAL COMPANY ORGANIZATIONAL CHART

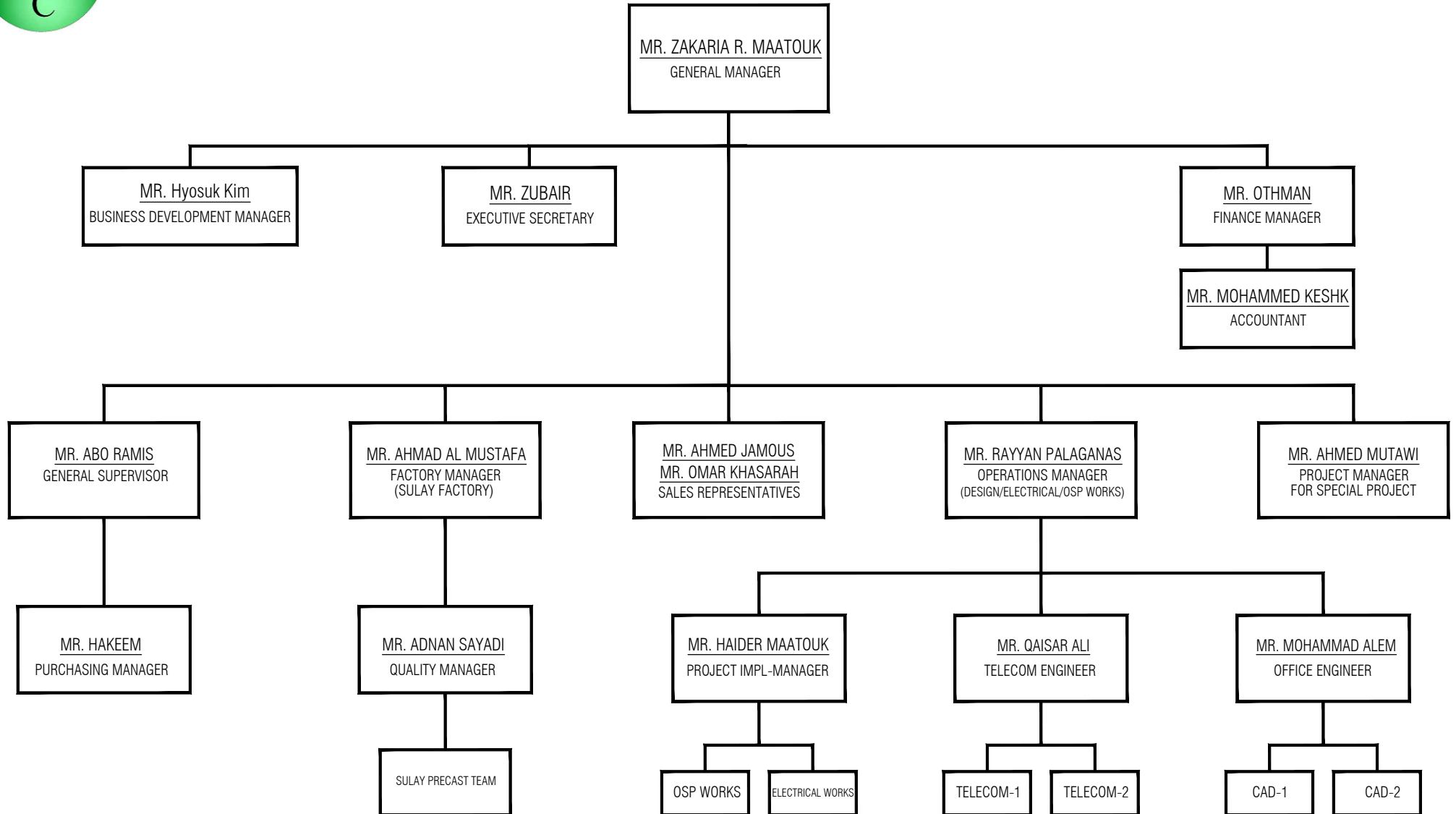



TECHNICAL DATA SHEET

S.No:	Description	Minimum Requirements	Specifications Conformed to
1.0	Precast Concrete		
1.1	Concrete Specification	Sulphate Resistant Cement (SRC, Type-V) conforming to ASTM C150.	STC/ITC/ZAIN/MOI/SEC
		Minimum compressive strength of 30MPa at 28 days(cube strength).	STC/ITC/ZAIN/MOI/SEC
1.2	Reinforcement Steel	Deformed steel bars with minimum Tensile strength of 300MPa, Grade-60 conforming to ASTM A615.	STC/ITC/ZAIN/MOI/SEC
1.3	Curing Compound	Conform to ASTM C309.	STC/ITC/ZAIN/MOI/SEC
1.4	External Coating	Apply two coats of Bitucure or alternates to walls exposed to earth.	STC/ITC/ZAIN/MOI/SEC
2.0	Cast Iron Cover		
2.1	Loading Capacity	Heavy Duty: 40 Tons, as per BS EN124 Class D400.	STC/ITC/ZAIN/MOI/SEC
		Medium Duty: 25 Tons, as per BS EN124 Class C250.	STC/ITC/ZAIN/MOI/SEC
2.2	Color	Black.	STC/ITC/ZAIN/MOI/SEC
3.0	Manhole and Handhole Accessories		
3.1	Material	The steel used for the manhole & handhole accessories shall comply with ASTM A-36 or equivalent. The steel accessories shall be galvanized according to ASTM A-123 or equivalent.	STC/ITC/ZAIN/MOI/SEC
3.2	Cable Bracket	Cable bracket shall be made of 400 thick steel, with capacity for vertical load $\geq 1.5\text{kN}$ and horizontal load $\geq 1\text{kN}$.	STC/ITC/ZAIN/MOI/SEC
3.3	Sump Cover	Sump cover, a square 400 x 400mm steel plate, with 10mm ϕ holes, shall stand a point load $\geq 100\text{kg}$.	STC/ITC/ZAIN/MOI/SEC
3.4	Pulling Eye	Pulling eye shall be 16mm ϕ plain bar and shall stand a pulling force $\geq 30\text{kN}$.	STC/ITC/ZAIN/MOI/SEC
3.5	Ladder	The ladder shall have 15mm ϕ rungs of corrugated steel bar.	STC/ITC/ZAIN/MOI/SEC
3.6	Ladder Hook	Ladder hook shall be fixed to a ladder rails with bolts, lock washers and nuts.	STC/ITC/ZAIN/MOI/SEC
3.7	Ladder Support	Ladder support shall be made from 15mm ϕ plain bar. It shall stand a point load $\geq 400\text{kg}$.	STC/ITC/ZAIN/MOI/SEC



Attachment #1

COMPANY BUSINESS

DOCUMENTS

(CR, Chamber of Commerce, GOSI, etc...)

CERTIFICATE OF REGISTRATION

INTERCERT hereby certifies that the Quality Management System of

DORAT AL TAL COMPANY FOR PRECAST MATERIALS

P. O. BOX 10700, OLAYA, RIYADH 11443, KINGDOM OF SAUDI ARABIA

Has been successfully assessed as per the requirements of

ISO 9001:2015

For the scope of

MANUFACTURING OF PRECAST MANHOLES, HANDHOLES, ROAD CROSSING, FOUNDATION, POLES AND CULVERTS, ETC.

Initial Certification Date : 04-08-2021
Certificate Issue Date : 04-08-2021
Surveillance Validity Date : 03-08-2022
Recertification Date : 03-08-2024

Registration Number: IC-QM-2108010



Issued on behalf of InterCert
Head - Certifications



MSCB-121



٧٠٠١٨٩٨٣٠٨

١٠١٠٢٢٣٩٨٩

١٤٢٧/٠٩/١٥ هـ

الرقم:

التاريخ:

شهادة تسجيل شركة

الاسم التجاري للشركة: شركة ذرة التل للمقاولات

نوعها: ذات مسؤولية محدودة

جنسيتها: سعودي

مدة الشركة: ٥٠ سنة

تبدأ من: ١٤٣٦/٠٢/٢٣ هـ وتنتهي في: ١٤٨٦/٠٢/٢٤ هـ

مركزها الرئيسي: الرياض - حي العليا - طريق مكة

ص ب: ١٦٨٢٩ الرمز البريدي: ١١٤٧٤ هاتف: ٤٦٦٠٤٠٨ فاكس: ٤٦٦١٠١٦

النشاط: صناعة أغطية غرف تفتيش الصرف الصحي*، إنشاء واصلاح الطرق والشوارع والارصفة ومستلزمات الطرق، إنشاء واقامة واصلاح محطات وابراج الاتصالات السلكية واللاسلكية والرادار، تركيب وتمديد شبكات الكمبيوتر والاتصالات، أنشطة خدمات صيانة المياني

*النشاط يتطلب الحصول على ترخيص من وزارة الطاقة والصناعة والثروة المعدنية

رأس المال: ٣٠٠٠٠٠٠ ريال سعودي

المديرون: ١ صفوان مصطفى عبدالله الاطرش

٢

٤

٦

٨

١٠

١٢

سلطات المدير/المديرون: حسب ما نص عليه عقد الشركة

يشهد مكتب السجل التجاري بمدينة: الرياض

بأنه تم تسجيل الشركة المذكورة أعلاه بمدينة: الرياض

وتنتهي صلاحية الشهادة في: ١٤٤٦/٠٢/٢٣

بموجب الإصدار رقم: ٤٥٨٣٣٥٣ وتاريخ: ١٤٤١/٠٢/١٨ هـ

الختم

مدير السجل التجاري الشركات: عبد الحسين بن إبراهيم الحماد

التوقيع:



Unified Membership No. : 101000172459

Date of Issue : 09/10/2006

Classification : Second

Riyadh Chamber of Commerce and Industry certifies that:

Commercial Register No 1010223989

Registered for this year.

The Certificate expires on 27/08/2024

رقم العضوية الموحد : ١٠١٠٠٠١٧٢٤٥٩

تاريخ الأصدار : ٢٠٠٦/١٠/٠٩

الدرجة : الثانية

تشهد الغرفة التجارية الصناعية بالرياض بأن :

شركة درة التل للمقاولات

المقيدة بالسجل التجاري / الترخيص رقم ١٠١٠٢٢٣٩٨٩

مشتركة لديها لهذا العام .

وينتهي سريان هذه الشهادة في ٢٧/٠٨/٢٠٢٤م

فاكس: 4661016

هاتف: 4660408

الرمز: 11474

ص.ب: 16829

مدير عام خدمات الاشتراكات

riyadhchamber

in t f g+ v



التاريخ ١٤٤٣/٠٤/٢٣
الموافق ٢٨/١١/٢٠٢١
رمز الشهادة ٤٢٤٥٦٥٥٦



شهادة

إسم المنشأة : شركة درة التل للمقاولات
ص.ب : ١٦٨٢٩ الرياض ١١٤٧٤
السعودية
رقم الإشتراك : ٥٠١٣٦٥٩٤٧
رقم السجل التجاري : ١٠١٠٢٢٣٩٨٩
مصدره : الرياض

رقما	كتابة	عدد المشتركين السعوديين
١٧	سبعة عشره مشتركا	عدد المشتركين غير السعوديين
٥٦	ستة و خمسون مشتركا	المجموع
٧٣	ثلاثة و سبعون مشتركا	

تشهد المؤسسة العامة للتأمينات الإجتماعية بأن المنشأة المذكورة أعلاه قد أوفت بالتزاماتها تجاه المؤسسة وفق البيانات المقدمة منها حتى تاريخ إصدار هذه الشهادة ، والتي تم منحها لتقديمها لأية جهة تطلبها ، وهي صالحة لجميع الأغراض التي نص عليها نظام التأمينات الإجتماعية في المادة (١٩/٦) منه.

هذه الشهادة سارية المفعول حتى ١٤٤٣/٠٥/٢٣ هـ.

يلزم التحقق من صحة وصلاحيه الشهادة عبر زيارة الرابط
أدناه في الموقع الإلكتروني للمؤسسة العامة للتأمينات الإجتماعية
أو عن طريق استخدام
الرمز المعرف التالي :



www.gosi.gov.sa/vc

(الشهادة معتمدة من صاحب الصلاحية ولا تحتاج إلى توقيع أو ختم)

ننهادت

www.gosi.gov.sa
800 1243344



تعد هذه الشهادة من الوثائق الإلكترونية الحكومية الرسمية ، ويحظر قطعيا تقليدها أو إدخال أي تعديلات عليها سواء بالإضافة أو الحذف أو التغيير في بياناتها أو غير ذلك من أنواع التعديل ، وتعد الشهادة لاغية إذا شابهها شيء من ذلك ، كما تعرض صاحبها للملاحقة النظامية أمام الجهات المختصة بالإضافة إلى مايفرضه نظام التأمينات الإجتماعية من عقوبات ، ولايجوز تداول الشهادة إلا في الأغراض التي أصدرت لأجلها وفقا لأحكام نظام التأمينات الإجتماعية ، والمؤسسة العامة للتأمينات الإجتماعية غير مسؤولة عن أي آثار أخرى مترتبة قبل الغير عن الشهادة وغير مسؤولة عن أي عملية تزوير أو تعديل تتم على البيانات الواردة فيها .

التأمينات الإلكترونية
بإمكانك من مكانك

شهادة سعودة

تاريخ الإصدار : ١٤٤٣/٥/٤
تاريخ صلاحية الشهادة : ١٤٤٣/٧/٥
رقم الشهادة : ٢٠٠٠٢١١٢٠٠٥٢٠٦

اسم المنشأة: شركة درة التل للمقاولات

رقم الملف: ١٠٧٦٠٩٣-١

سجل تجاري: ١٠١٠٢٢٣٩٨٩

الصادر من: الرياض

تشهد وزارة العمل والتنمية الاجتماعية بأن المنشأة المذكورة أعلاه حققت نسب التوطين المطلوبة منها..
وتم منحها هذه الشهادة حسب طلبها

(الشهادة معتمدة من صاحب الصلاحية ولا تحتاج إلى توقيع أو ختم)

تنبيهات:

١ - يمكن التحقق من صحة وصلاحية الشهادة عبر زيارة الرابط:

٢ - في حال اكتشاف أي عملية تزوير في الشهادة المقدمة نرجو التبليغ عن ذلك بخطاب رسمي لأقرب مكتب عمل.



رقم الشهادة: ١٠٢٠٨٣٥٦٧٠
التاريخ: ١٤٤٢/١١/٢٠ هـ
الرقم المميز: ٣١٠٠٧١٩٧٥٩



الهيئة العامة للزكاة والدخل
General Authority of Zakat & Tax

المملكة العربية السعودية
الهيئة العامة للزكاة والدخل
General Authority of Zakat & Tax

شهادة CERTIFICATE

تشهد الهيئة العامة للزكاة والدخل بأن المكلف / شركة درة التل للمقاولات

شركة رقم ٧٠٠١٨٩٨٣٠٨ وسجل تجاري رقم ١٠٢٢٣٩٨٩

قدم إقراره عن الفترة المنتهية في ٢٠٢٠/١٢/٣١ م

وقد منح هذه الشهادة لتمكينه من إنهاء جميع معاملاته بما في ذلك صرف مستحقاته
النهائية عن العقود.

يسري مفعول هذه الشهادة حتى تاريخ ١٤٤٣/٠٩/٢٩ هـ الموافق ٢٠٢٢/٠٤/٣٠ م.

(التاسع و العشرون من رمضان ألف و أربعمائة و ثلاثة و أربعون هجري)

الفروع (١) في النموذج المرفق



الختم الرسمي

هذه الوثيقة مستخرجة من النظام الآلي ولا تحتاج إلى توقيع

لا يعتد بهذه الشهادة إلا بعد التحقق من موقع الهيئة www.gazt.gov.sa



رقم الشهادة: ١٠٢٠٨٣٥٦٧٠
التاريخ: ١٤٤٢/١١/٢٠ هـ
الرقم المميز: ٣١٠٠٧١٩٧٥٩



الهيئة العامة للزكاة والدخل
General Authority of Zakat & Tax

المملكة العربية السعودية
الهيئة العامة للزكاة والدخل
General Authority of Zakat & Tax

قائمة فروع المكلف شركة درة التل للمقاولات

رقم السجل	الرخصة	إسم الفرع	المدينة
٢٠٥٠١٠٨٣٦٥		فرع شركة درة التل للمقاولات	



الختم الرسمي

هذه الوثيقة مستخرجة من النظام الآلي ولا تحتاج إلى توقيع

لا يعتد بهذه الشهادة إلا بعد التحقق من موقع الهيئة www.gazt.gov.sa



تاريخ الترخيص : ١٤٣٨/١٢/٠١ هـ
الرقم المميز : ٣١٠٠٧١٩٧٥٩



الهيئة العامة للزكاة والدخل
GENERAL AUTHORITY OF ZAKAT & TAX

المملكة العربية السعودية
الهيئة العامة للزكاة والدخل
GENERAL AUTHORITY OF ZAKAT & TAX
(١٨٥)

شهادة CERTIFICATE

شهادة تسجيل في ضريبة القيمة المضافة VAT registration certificate

تشهد الهيئة العامة للزكاة والدخل بأن المكلف : شركة درة التل للمقاولات
مسجل في ضريبة القيمة المضافة بتاريخ : ١٤٣٨/١٢/٠١ هـ، وتحمل الرقم الضريبي : ٣١٠٠٧١٩٧٥٩٠٠٠٠٣

عنوان المركز الرئيسي :
المدينة : الرياض الحي :
صندوق البريد : الرمز البريدي : ١١٢٢٢
الهاتف : ٠٠٩٦٦٥٥٢٢٠٥٨٤٤

الهيئة العامة للزكاة والدخل



هذه الوثيقة مرسله من النظام الآلي ولا تحتاج إلى توقيع



موافقة مبدئية

مدة الترخيص سنة قابلة للتجديد

رقم الترخيص ٤١٦٠٠١٨١٣٩ تاريخه ١٤٤٣-٠٢-٠٢ تاريخ الإنتهاء ١٤٤٣-٠٧-٠٧

بيانات المنشأة الصناعية

اسم المنشأة الصناعية مصنع شركة درة التل للمنتجات الخرسانية
موقع المنشأة الصناعية الرياض
ذات مسؤولية محدودة الكيان القانوني

بيانات صاحب المنشأة الصناعية

اسم صاحب المنشأة الصناعية: شركة درة التل للمقاولات
رقم السجل التجاري: 1010223989
المدينة: الرياض
الجوال: +٩٦٦٥٠٢٠٠١٢
البريد الإلكتروني: safwan0506@hotmail.com

المنتجات

صناعة قواطع وألواح وأطر ومباني جاهزة من الخرسانة سابقة الصنع

٦٨١٠٩١٠٠٣١	منتجات خرسانية مسبقة الصنع
٦٨١٠٩١٠٠٩٠	خرسانة مسبقة الصنع

صناعة المنتجات المعدنية الإنشائية وأجزائها الأخرى

٩٤٠٦٠٠٩٠١٦	وحدات خرسانية مسلحة مسبقة الصب
------------	--------------------------------





بلدي
balady



رخصة نشاط تجاري Commercial Activity Licence شركة درة التل للمقاولات

License Expiry Date	تاريخ انتهاء الرخصة	Payment Due Date	تاريخ انتهاء فترة السداد	License Number	رقم الرخصة الموحّد
1444/01/08		1444/01/08		40031919394	

Owner's Name	اسم المالك
شركة درة التل للمقاولات - - -	

Owner's ID	رقم هوية المالك
1010223989	

ISIC Classification	التصنيف الصناعي القياسي الدولي (نشاط ايزك)
ترميمات المباني السكنية والغير سكنية	

Detailed Activity	النشاط التفصيلي
ترميمات المباني السكنية والغير سكنية	

Sub-Municipality	البلدية
بلدية الملز	

Municipality	الأمانة
أمانة منطقة الرياض	

Street	الشارع
طريق مكة المكرمة	

District	الحي
العليا	

Shop's Sign's Area	مساحة اللوحات الإجمالية
1 متر مربع ارشادي 0 متر مربع اعلاني	



موقع المحل

Shop's Total Area	مساحة المحل الإجمالية
168 متر مربع	

Permit Expiry Date	تاريخ انتهاء التصريح	Permit Number	رقم التصريح	Permits	التصاريح

مركز الدعم الفني
199099

saudimomra

www.balady.gov.sa

Attachment #2

APPROVAL CERTIFICATES

from

VENDOR/CLIENTS

Cer. NO : RQ-0019
Approval Date : 26/Nov/2021
Valid Up To : 28/Aug/2023

شهادة اعتماد النوعية TYPE APPROVAL CERTIFICATE

stc

This is to certify that the undernoted manufacturer has been approved for the listed products below in accordance to STC specifications:

تم منح هذه الشهادة للمصنِّع الموضح بياناته لقائمة المنتجات أدناه حسب مواصفات STC:

Manufacturer Name **Dorat Al-Tal Company for Contracting**

اسم المصنِّع : **شركة درة التل للمقاولات**

Country of origin **KSA**

بلد المنشاء : **المملكة العربية السعودية**

For Below Products:

للمنتجات التالية :

Ser No.	Mic No.	AR/Description	EN/Description	Spec. Issue
1	1917019000977	فتحة التفتيش مسبقة الصنع بغطاء مفرد (مشروع الفاير)	Handhole, 1 cover, Precast Concrete (FTTH Project)	VM103 / 6
2	2718200300006	القاعدة الخرسانية لكبائن توصيل الألياف الزجاجية جبل الثاني، نوع 3:768	FDT Concrete Base ,GEN 2, Type 3:FDT 768	VM104 / 5
3	1917019000985	غرفة التفتيش مسبقة الصنع نوع أ	Manhole, Precast Concrete Type A	VM101 / 5
4	1917019000993	غرفة التفتيش الصغيرة مسبقة الصنع (إف تي تي اتش)	Mini Manhole, Precast Concrete (FTTH Project)	VM101 / 5
5	1917019000979	فتحة التفتيش مسبقة الصنع بغطائين (مشروع الفاير)	Handhole, 2 covers, Precast Concrete (FTTH Project)	VM103 / 6

مدير إدارة ضمان الجودة التقنية
Technology Quality Assurance Director

مدير شعبة المواصفات والمعايير التقنية
Technology Standardization Section Manager

م / بدر بن محمد السعيد

م / بدر بن عبد الرحمن الرشيد



Very Important:-

1-Receipt of this certificate from Type Approval Applicant will be considered a full compliance commitment with the mentioned technical specifications in this certificate with latest updates provided to him.

هام جداً :-

1- إن استلام طالب الاعتماد لهذه الشهادة يعتبر تعهداً منه بالالتزام التام بالمواصفة الفنية المنصوص عليها في هذه الشهادة مع آخر تحديثات المواصفة التي يتم تزويده بها .

This Certificate has been printed and stamped electronically and doesn't need a signature

Cer. NO : RQ-0019
Approval Date : 26/Nov/2021
Valid Up To : 28/Aug/2023

شهادة اعتماد النوعية TYPE APPROVAL CERTIFICATE



This is to certify that the undernoted manufacturer has been approved for the listed products below in accordance to STC specifications:

تم منح هذه الشهادة للمصنِّع الموضح بياناته لفائمة المنتجات أدناه حسب مواصفات STC:

Manufacturer Name **Dorat Al-Tal Company for Contracting**

اسم المصنِّع : **شركة درة التل للمقاولات**

Country of origin **KSA**

بلد المنشاء : **المملكة العربية السعودية**

For Below Products:

للمنتجات التالية :

Ser No.	Mic No.	AR/Description	EN/Description	Spec. Issue
1	1917019000973	غرفة التفتيش الصغيرة مسبقة الصنع (إف تي تي اتش)	Mini Manhole, Precast Concrete FTTH Project-window	VM101/5
2	1917019000963	فتحة التفتيش مسبقة الصنع بغطاء مفرد (مشروع الفاير)	Handhole, 1 cover, Precast Concrete FTTH Project-Window	VM103 / 6
3	1917019000964	فتحة التفتيش مسبقة الصنع بغطائين (مشروع الفاير)	Handhole, 2 covers, Precast Concrete FTTH Project-Window	VM103 / 6

مدير إدارة ضمان الجودة التقنية
Technology Quality Assurance Director

مدير شعبة المواصفات والمعايير التقنية
Technology Standardization Section Manager

م / بدر بن محمد السعيد

م / بدر بن عبد الرحمن الرشيد



Very Important:-

1-Receipt of this certificate from Type Approval Applicant will be considered a full compliance commitment with the mentioned technical specifications in this certificate with latest updates provided to him.

هام جداً :-

1- إن استلام طالب الاعتماد لهذه الشهادة يعتبر تعهداً منه بالالتزام التام بالمواصفة الفنية المنصوص عليها في هذه الشهادة مع آخر تحديثات المواصفة التي يتم تزويده بها .

This Certificate has been printed and stamped electronically and doesn't need a signature

Cer. NO : RQ-002316
Approval Date : 06/Apr/2021
Valid Up To : 06/Jan/2023

شهادة اعتماد النوعية TYPE APPROVAL CERTIFICATE

stc

This is to certify that the undernoted manufacturer has been approved for the listed products below in accordance to STC specifications:

تم منح هذه الشهادة للمصنع الموضح بياناته لقائمة المنتجات أدناه حسب مواصفات STC :

Manufacturer Name : DORAT AL TAL COMPANY FOR CONTRACTING

اسم المصنع : شركة درة التل للمقاولات

Country of origin : KSA

بلد المنشاء : المملكة العربية السعودية

For Below Products:

للمنتجات التالية :

Ser No.	Mic No.	AR/Description	EN/Description	Spec. Issue
1	1917019000989	غرفة التفتيش مسبقة الصنع نوع ب	Manhole, Precast Concrete Type B	VM101 / 5
2	1917019000990	غرفة التفتيش مسبقة الصنع نوع ج	Manhole, Precast Concrete Type C	VM101 / 5

مدير إدارة ضمان الجودة التقنية
Technology Quality Assurance Director

مدير شعبة المواصفات والمعايير الفنية
Technology Standardization Section Manager

م / بدر بن محمد السعيد

م / بدر بن عبد الرحمن الرشيد



Very Important:-

1-Receipt of this certificate from Type Approval Applicant will be considered a full compliance commitment with the mentioned technical specifications in this certificate with latest updates provided to him.

هام جدا :-

1- إن استلام طالب الاعتماد لهذه الشهادة يعتبر تعهدا منه بالالتزام التام بالمواصفة الفنية المنصوص عليها في هذه الشهادة مع آخر تحديثات المواصفة التي يتم تزويده بها .

This Certificate has been printed and stamped electronically and doesn't need a signature

Ref. No.: 394
 Sunday, November 7, 2021
 Certificate No.: Mobily/TAC/HH-MH/394

This certificate is valid from:

7-Nov-21	To	6-Nov-22
----------	----	----------

Name of the Manufacturer / Supplier: **DORAT AL-TAL CO**





Address of Manufacturer / Supplier: PO BOX 10700, RIYADH 11443, KSA

Type of Approval (~~Provisional~~/ Periodic):

Product(s) details:

Product- Name / Code	Description
Handholes and Manholes	Handhole One Cover (OD: 900mm x 900mm x 1000mm and ID: 600mm x 600mm x 850mm) Handhole Two Cover Hinge Type (OD: 1550mm x 900mm x 1100mm and ID: 1250mm x 600mm x 850mm) Mini-Manhole Type-1 With Cover Hinge Type (OD: 1550mm x 1550mm x 1980mm and ID: 1200mm x 1200mm x 1200mm) Handhole Round cover Type-1 With Cover Hinge Type (OD: 1200mm x 1200mm x 1350mm and ID: 900mm x 900mm x 700mm) Handhole Round cover Type-2 With Cover Hinge Type (OD: 1300mm x 1300mm x 1600mm and ID: 1000mm x 1000mm x 1000mm) (Other spec as stated in Mobily standards)

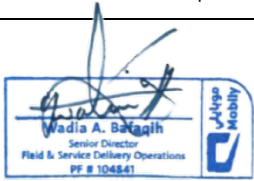
This certificate is valid with the terms and conditions applied by Mobily regarding the type approval

Verified By:	Verified By:	Verified By:
Asad Saeed Khan Section Head Transport Planning & Design	Wafi Mohamed Zahlan Section Head Transport Implementation	Wadia A. Bafaqih Director Network Site Field Operation
		
Approved By:	Feras T. Alfariss General Manager Transport Planning & Design	

Remarks(Terms & Conditions if any):

- . For Immediate Effect
- . For All OSP Contractors





Integrated Telecom Company-ITC

ITC-BB-2020-List of Approved Suppliers

OSP Network Engineering

Riyadh – Saudi Arabia

14-Aug-2017

2.2. Approved Supplier for Handhole and Manholes

Manufacturer / Supplier Details		Contact	Country of Origin
2.2	Dorat Al Tal Company	P.O Box : 16829, Riyadh 11474 Riyadh , Kingdom of Saudi Arabia Mob. No.: +966-530221993 Tel.: 01-466 0408 Ext. 101 Fax: 01-466 1016Email: dorat@doratal.com Location: 24.681388, 46.695926	Saudi Arabia
	Approved material:		
All ITC Concrete strutcures including: (All specs as per ITC approved Design) Manholes - Type A, Mini Type 1 / 2 (For Normal Duct entry and Micro Duct entry) Handholes - 1 cover / 2 Cover (For Normal Duct entry and Micro Duct entry) Pedestial Base - Tyco / R&M FDT Cabinet Base)(For Normal and Micro Duct entry) Protection Posts - 300 and 150 mm Dia. Marker Posts			

11 Regional Infrastructure

Regional Infrastructure

NEOM

Saudi Arabia



MAIL TYPE
Workflow Transmittal

MAIL NUMBER
ACM-WTRAN-000739

REFERENCE NUMBER
ACM-WTRAN-000739

Final (WF-000331) 11-1100000016/000-IN-Construction - IFR

From Mr Mouneimne Ahmad - AECOM

To (2) Neom Pmc Region 01 - AECOM
Mr Mouneimne Ahmad - AECOM

Cc (6) Werner Van Straaten - AECOM
Mr Imran Mohammed - AECOM
DC NEOM - NEOM - Projects
NEOM Regional DC - NEOM - Projects
Mr Abdulsalam Alharbi - NEOM - Projects
Mr 1100000016DCC SAPAC - SAUDI PAN KINGDOM, SAPAC

Sent Tuesday, 19 January 2021 10:58:19 AM AST (GMT +03:00)

Status N/A

DOCUMENT ATTACHMENTS (1)

(0 selected)

File	Document No	Revision	Revision Date	Title	Status
	11-000000-1100000016-SPC-ELE-MAT-000017	01	09/01/2021	1100000016/00 – Telecom Manhole (JRC-12) – (Dorat Al-Tal co)	Work May proceed

MESSAGE

Workflow Review History

The attached documents have completed the "11-1100000016/000-IN-Construction - IFR" workflow with the following results :

This transmittal was automatically generated.

Doc No	Step	Participant	Review Outcome	Comments
11-000000-1100000016-SPC-ELE-MAT-000017	NEOM/AECOM_Review	M Ahmad	Work May Proceed	

Submittal Reference #: IMA-1136-E-PRQ-CV-0001-00	Date: 13/10/2020
Project Name: Design & Build Substation for private Air Terminal PO#4500001136	Contractor: I-MANCO
RAC Project Manager: Hazaa EL-Ghalby	Consultant: WSP

Submittal Details (by the Contractor)

Type of Submittal:

<input type="checkbox"/> Material	<input type="checkbox"/> Shop Drawings	<input type="checkbox"/> Design Drawings	<input type="checkbox"/> Test Report	<input type="checkbox"/> Manufacturer's Data
<input type="checkbox"/> Method Statement	<input checked="" type="checkbox"/> Prequalification	<input type="checkbox"/> As- Built Drawings	<input type="checkbox"/> Sample	<input type="checkbox"/> Catalogues
<input type="checkbox"/> Others:				

Discipline:

<input type="checkbox"/> Architectural	<input checked="" type="checkbox"/> Civil/ Structure	<input type="checkbox"/> Mechanical	<input type="checkbox"/> Electrical	<input type="checkbox"/> Project Controls	<input type="checkbox"/> General
--	--	-------------------------------------	-------------------------------------	---	----------------------------------

Submittal Description:

#	Description	Revision	Date	Copies
1-	Prequalification for Dorat AL-Tal company that will supply the precast concrete for substation building roof slab & the concrete duct for cable route roads crossing	00	13/10/2020	Soft Copy
Submitted By/ Kamran Alam			Designation/QHS Manger	
			DATE AND SIG:	

Documents Review (by RAC's Execution Team)

Accepted
 Rejected

Reviewed by: A.HAFEEZ	Date: 21-10-20	Signature: <i>S.HAFEEZ</i>
-----------------------	----------------	----------------------------

Technical Review (by RAC's Engineering Team)

A: Approved
 B: Approved as Noted
 C: Revise & Resubmit
 D: Rejected



Prequalification for the Precast supplier (Dorat AL- TAL) is found acceptable. The contractor shall submit the related drawings and MS for RAC review and approval.

Consultant: Hossam	Date: 22.10.2020	Signature:
Discipline Engineer: Mohammad Altwaijri	Date: 22.10.2020	Signature:

Approval shall not relieve Contractor of his liabilities under the Contract or constitute authorization of any change to Contract Documents.

Supervision and Management Services for
King Faisal Air Academy Facilities Relocation and Construction Project, Majm'a

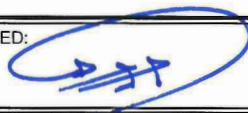
TRANSMITTAL FORM

TRANSMITTAL NO. DAR-RSA-TR-201202-01			
SUBJECT: Prequalification for Dorat Al-Tal Co for Contracting For Telecom Precast Manholes and Handholes			DATE: 2-Dec-2020
FROM: <input checked="" type="checkbox"/> Project Director Office <input type="checkbox"/> Technical Office Director <input type="checkbox"/> Project Controls Director <input type="checkbox"/> Quality Management Director <input type="checkbox"/> HSE Director <input type="checkbox"/> Finance and Contract Director <input type="checkbox"/> Documents Control Director <input type="checkbox"/> Construction Management Director		TO: <input checked="" type="checkbox"/> RSAF <input type="checkbox"/> Nesma & Partners & JV "Al Mabani & ATS" <input type="checkbox"/> Al Bawani, Shibh Al Jazira & Salini Impregilo <input type="checkbox"/> BAE Systems <input type="checkbox"/> Other: _____ CC: _____	
WE ARE SENDING Y <input checked="" type="checkbox"/> Attached <input type="checkbox"/> Under separate cover via: _____ the following items: <input type="checkbox"/> Drawings <input checked="" type="checkbox"/> Documents <input type="checkbox"/> Studies <input type="checkbox"/> Samples <input type="checkbox"/> Specifications <input type="checkbox"/> Copy of letter <input type="checkbox"/> Change order <input type="checkbox"/> Other: _____			
NO.	DATE	COPIES	DESCRIPTION
1	2-Dec-2020	1	1- Commented For BSS-0-GE00-CP069-0143-R00 - BSS-SB-0-GE00-DC-0870-R00
WE ARE SENDING YOU <input checked="" type="checkbox"/> For approval <input type="checkbox"/> For review and comment <input type="checkbox"/> As requested <input type="checkbox"/> For information <input type="checkbox"/> Other: _____ REMARKS: <i>Approved by the RSAP</i>			
SENDER'S NAME: Abdalaziz Al-Hamlan		JOB TITLE: Project Director	SIGNED:  Date: 02-Dec-20
Acknowledgement of Receipt (kindly acknowledge receipt and return this sheet to the sender)			
RECEIVED BY:		JOB TITLE:	SIGNED:  Date: 3/12/2020
Disclaimer: 1.This transmittal is intended for the subject and purpose indicated above only. 2.Any information in this document shall not be binding nor comprising any changes in the contract document unless submitted and approved by KFAA through the appropriate documentation channel.			

King Faisal Air Academy Facilities
Relocation and Construction Project, Majmaah

PREQUALIFICATION REVIEW SHEET

Client: RSAF Consultant: DAR AL RIYADH		Contractor: BSS JV	
Prequalification document for : Dorat Al-Tal Co for Contracting For Telecom Precast Manholes and Handholes		CLASSIFICATION <input checked="" type="checkbox"/> MANUFACTURER <input checked="" type="checkbox"/> SUPPLIER ONLY <input type="checkbox"/> SUBCON/ INSTALLER <input type="checkbox"/> DESIGNER <input type="checkbox"/> LABORATORY BLDG NO./ FACILITY facility Submission Planned Date:	DISCIPLINE <input type="checkbox"/> ARCHITECTURE <input type="checkbox"/> INTERIOR DESIGN <input type="checkbox"/> CIVIL <input type="checkbox"/> STRUCTURAL <input type="checkbox"/> MECHANICAL <input type="checkbox"/> ELECTRICAL <input checked="" type="checkbox"/> TELECOM <input type="checkbox"/> LANDSCAPE <input type="checkbox"/> SURVEY <input type="checkbox"/> OTHER()
BOQ ITEM REF: PHASE NO: 0		REFERENCE# BSS-0-GE00-CP069-0143-R00-FORM PREQUALIFICATION SUBMITTAL: <input checked="" type="checkbox"/> New Submittal <input type="checkbox"/> Re-submittal SPECS. REFERENCE: pProject Drawings 1422-04-TS-004,008,009,010& STC standards	

Proposed Manufacturer / Supplier/ Installer:			
COMPANY NAME	CONTACT PERSON	CONTACT NUMBER	
1 Dorat Al-Tal co for contracting	Eng.Ahmad Jamos	050 440 2963	

SUBMITTAL MANDATORY ATTACHMENT CHECKLIST (Contractor to check & verify all legal doc.content are valid & latest).

<input checked="" type="checkbox"/> Company profile	<input checked="" type="checkbox"/> Chamber of Commerce	<input checked="" type="checkbox"/> Organizational Structure	<input type="checkbox"/> RSAF prequalification criteria
<input checked="" type="checkbox"/> Completed project list (scope related)	<input checked="" type="checkbox"/> GOSI Certificate	<input checked="" type="checkbox"/> Manpower & tech. & skill staff	<input checked="" type="checkbox"/> Machinery & equipments
<input checked="" type="checkbox"/> Commercial Reg .(Commerce & Investment)	<input checked="" type="checkbox"/> Zakat & Tax Cert.	<input checked="" type="checkbox"/> Completed proj.list(scope related)	<input type="checkbox"/> SCE Certificate
<input type="checkbox"/> Saudi Contractors Authority (SCA) Cert.	<input checked="" type="checkbox"/> VAT Cert.	<input checked="" type="checkbox"/> List of Current projects.	<input type="checkbox"/> Non Disclosure Agreement Cert.
<input checked="" type="checkbox"/> Saudization Certificate	<input checked="" type="checkbox"/> ISO Certificate	<input checked="" type="checkbox"/> Mfc. Production capacity	<input type="checkbox"/> Mfc-Installer/Sup. Accredited Cert.
FACTORY VISIT <input type="checkbox"/> Required <input type="checkbox"/> Not Required	<input type="checkbox"/> Conflict of Interest disclosure		<input type="checkbox"/> Prev. client Informed consent

We certify that the above submitted documents have been reviewed in detail and are correct and in strict conformity with the contract requirements .

Submitted by: Mohammad Abdul Raheem
Contractor Representative

 **BSS** JOINT VENTURE
Signature

25-Noov-2020
Date

DAR RECOMMENDATION

<input type="checkbox"/> A- Approved	Construction / fabrication / installation may be undertaken
<input checked="" type="checkbox"/> B- Approved as noted	Approval does not authorize changes in the contract sum or contract time
<input type="checkbox"/> C- Revise and Resubmit	Construction / fabrication / Installation may not be undertaken
<input type="checkbox"/> D- Rejected	In resubmitting, limit corections to the items marked

Approval shall not relieve Contractor of his liabilities under the Contract or constitute authorization of any change to Contract Documents

Summary Comments

see attached prequalification, **CONTRACTOR TO SUBMIT & SECURE THE APPROVAL OF HIGH LEVEL DESIGN AND COMPLY WITH DCIT REQUIREMENT.**

Dar Al Riyadh (refer to attached for detailed comments)

Finance and Contracts Director

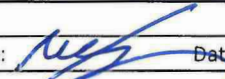
Name: Moustafa Ismail Signature:  Date: 02/12/2020

Project Director

Name: Abdulaziz Abdulrahman Alhamlan Signature:  Date: 02/12/2020

Final Approval Status

 Comments As per DAR review & approval	<input checked="" type="checkbox"/> Approved
	<input type="checkbox"/> Rejected

Quality Assurance

Name: Signature: Date:

Project Director

Name: Colonel Sultan Alghthami Signature:  Date: **28/12/2020**



MATERIAL APPROVAL REQUEST

SUBCONTRACTOR NAME: NOUR COMMUNICATION

CONTRACT NO.:

Date: 25-Oct-16

MAR NO.: Nour/GPT/Jebel Hith/0001-M-R1

Rev. No.: 01

Material Classification:

- BUILDING CIVIL STRUCTURAL MECHANICAL
 ELECTRICAL INSTRUMENT OTHERS

Material Description:

- Handhole One Cover (Single Chamber)
- Handhole Two Cover (Double Chamber)

Manufacturer:

Dorat AL-Tal Co.

Supplier:

Dorat AL-Tal Co.

Specifications: See attachment 1

Technical Details: See attachment 1

Attachment:

Sample:	Catalogue/ Brochure	Company Profile:	Test Certificates:
<input checked="" type="checkbox"/> Yes	<input type="checkbox"/> Yes	<input checked="" type="checkbox"/> Yes	<input type="checkbox"/> Yes
<input type="checkbox"/> No	<input type="checkbox"/> No	<input type="checkbox"/> No	<input type="checkbox"/> No

Requester: Faisal Bani Ata

Submitted By: Faisal Bani Ata

Date: 25-Oct-16

Approved By: Faisal Bani Ata

Date: 25-Oct-16

For GPT Review

Comments:

Ensure ring rebars are of size 14φ (not 4φ) and spaced @ 100mm as per NDR. Drawing to be updated

- Yes Yes Yes Yes
 Approved Approved with Comments Revised/Resubmit Rejected

Signed by GPT Representative

Name: *WILF MACALAN*

Title: *IDB*

Signature: *[Signature]*

For Authorities Approval

Comments:

- Yes Yes Yes Yes
 Approved Approved with Comments Revised/Resubmit Rejected

Signed by Authorities Representative

Name:

Title:

Signature:





SOUTH DHAHRAN HOME OWNERSHIP PROJECT
Transmittal Form (TR)



TR #: 01/08/00013/TR/00/02133 Rev. #: 01 Date: 12-Jun-17

Contractor: Consortium-Azmeel Contracting Company/Sinohydro Co.
 Contract Title: South Dharan Home Ownership Development Program
 Contract No.: 6600036216
 To: Company Representative Attn.: Engr. Mohamed A. Al-Naser

SUBMITTED	CODE	ACTION	CODE
FOR ACTION	1	NO OBJECTION	A
FOR INFORMATION	2	NO OBJECTION AS NOTED	B
		REVISE AND RESUBMIT	C
		REJECTED	D

WE ARE SENDING HERewith THE DRAWING / DOCUMENTS LISTED BELOW. (DELETE AS NECESSARY)

ITEM	QTY.	Dwgs., Specs. or BOQ Ref.	DOCUMENT / DRAWING NO.	DESCRIPTION	TYPE OF SUB*	DISCIPL**	CODE	
							SUBMIT. FOR	ACTION
1	3 Sets		AS-A18-EL-0466-Rev-01	Please find the attached Telecommunication Hand Hole & Cover (Saudi Ready Mix Concrete Co/Dorat Al-Tal Co) for your review and approval	OT	PR	1	A
	1 CD							

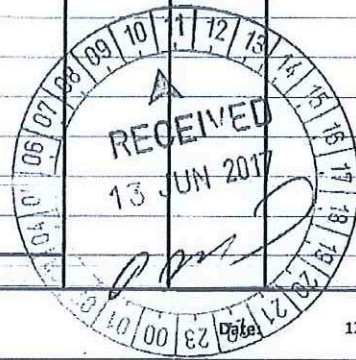

Only one subject is allowed to be submitted under this transmittal

FOR CONTRACTOR:
 Name: Engr. Mohamad El Ghor Signature:  Date: 12-Jun-17

*Type of Submittal: 60=60% Design Drawings | 90=90% Design Drawings | IFC=Issue for Const. | SD=Shop Drawing | TE=Technical | GT=Guarantee
 TT=Test | MD=Mfr's Data | CA=Calculations | CT=Certificates | SP=Specification | CI=Catalogues | Other: _____

**Discipline: AR = Arch. | ME = Mech. | ST = Structural | EL = Elect./Telecom | IS = Infra. | LD = Landscape | HSE | QA/QC | PCS | PR=Proc. | CN=Contractual | Others: _____

Reviewed for General Acceptance. This review does not relieve the Contractor of his responsibility for making the work conform to the requirements of the Contract

Remarks and Comments if Any: No Objection.

Correction or comments made relative to submittals during this review DO NOT relieve the contractor from compliance with the requirements of drawings and specifications. This check is only for review of general conformance with design concept of the project.

SAPMT PMT/CMT PMT
 Name: Engr. Mohamed A. Al-Naser Signature:  Date: 6-15-17

Distribution: SAPMT PMT PMT/CMT Other _____

For ASME
4/15/17
AS



MATERIAL TECHNICAL SUBMITTAL

TO: Saudi Aramco South Dhahran Home Ownership Housing and Community Facilities - District 2D & 2E Dhahran, Saudi Arabia ATTN: Mr. Mohamed El Naser Project Manager FROM: Azmeel Contracting Co. Branch of Sinohydro Corporation Limited P.O. Box 1498 Address: BUILDING NO.6517, Al-Khobar, 31952 ALTAKHASUSI Road, Riyadh 12311 Saudi Arabia Mob : +966 558068444 Tel: 013 826-7250 Tel: +966 18030338 Fax: 013 826-2196 Fax : +966 14622565	BIJD No. : 23-00013 CONTRACT No. : 660036216 PROJECT TITLE : South Dhahran Home Ownership Project (SDHOP), District 2D & 2E LOCATION : DHAHRAN, SAUDI ARABIA	No. of Copies: 3 SPECS REF.: DETAILED SCOPE OF WORK SECTION No.: SECTION 3 DRAWING REFERENCES: HB-023228-001-0A APPLICABLE STANDARD:	SUBMITTAL CODE A <input type="checkbox"/> Architectural C <input type="checkbox"/> Civil S <input type="checkbox"/> Structural M <input type="checkbox"/> Mechanical E <input type="checkbox"/> Electrical I <input checked="" type="checkbox"/> Telecommunication O <input type="checkbox"/> Others
	MATERIAL DESCRIPTION TELECOM HANDHOLES, COVERS & ACCESSORIES		

New Submittal <input type="checkbox"/> Re-submittal <input checked="" type="checkbox"/>	REFERENCE SUBMITTAL NO AS-A18-EL-0466	REV. NO. 1	DATE June 8, 2017	Attachments:	Data Sheet/ Catalogue Samples <input checked="" type="checkbox"/>	Test Certificates <input checked="" type="checkbox"/> Other Documents <input checked="" type="checkbox"/>	Inspection Category N/A
--	--	---------------	----------------------	--------------	---	--	----------------------------

SN	MATERIAL DESCRIPTION	MANUFACTURER NAME	VENDOR NAME & CONTACT DETAILS	(FOR SAUDI ARAMCO USE ONLY) REVIEW/COMMENTS/APPROVAL/ACTION
1	DESIGN MIX (CONCRETE READYMIX) 5000 psi	Concrete Supplied by: SAUDI READYMIX CONCRETE CO. AJYAL PLANT, DHAHRAN Batch Plant # 1 (SN: 95120) 9COM: 6000000453	SAUDI READYMIX CONCRETE CO. AJYAL PLANT, DHAHRAN Batch Plant # 1 (SN: 95120)	
2	PRECAST CONCRETE (CASTING AT SITE)	Element Casted by: AZMEEL CONTRACTING CO.	AZMEEL CONTRACTING CO.	
3	TELECOM HANDHOLE COVERS, BRACKETS, SUPPORTS, MOULDS, ACCESSORIES, ETC. AREA OF LOCATION FOR INSTALLATION: INFRASTRUCTURE FOR TELECOM HANDHOLES	DORAT AL-TAL CO. Engr. Rayyan 053 032 2816 STC APPROVED 4121970	DORAT AL-TAL CO. Engr. Rayyan 053 032 2816 STC APPROVED 4121970	<input checked="" type="checkbox"/> Approved <input type="checkbox"/> Correct & Resubmit <input type="checkbox"/> Approved with Comments <input type="checkbox"/> Rejected

Prepared By: Procurement Engineer Date: 8-6-2017	Reviewed By: PQCS Date:	Reviewed By: Technical Manager Date:	Approved By: Contractor Representative Date:	Reviewed By: SAPMT Material Specialist Date: June 15, 17	Reviewed By: SAPMT Project Engineer Date:	Reviewed By: SAPMT Quality Date: 09/15/17
				Approved By: Company Representative Date: 6-15-17		



Vendor 3: Dorat ATel - SUPPORTING DOCUMENTS (Page 8 of 8)

Dorat ATel

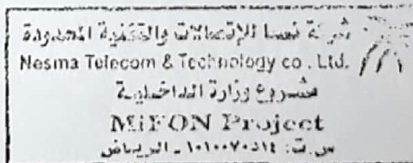

We the manufacturer of the above product confirm that we have read through and understood all the requirements presented in the bid for the aforementioned material. We hereby certify that the provided material is to the specification and quality requirement of Ministry of Interior of Kingdom of Saudi Arabia as per tender reference defined on page 1 of this document

MANUFACTURER AUTHORIZED SIGNATORY: _____

SEAL OF MANUFACTURER: _____

VENDOR 1 MATERAIL APPROVAL STATUS	COMMENTS	STAMP
<input checked="" type="checkbox"/> APPROVED <input type="checkbox"/> ACCEPTED WITH COMMENTS <input type="checkbox"/> REJECTED <input type="checkbox"/> TEMPORARY APPROVAL		

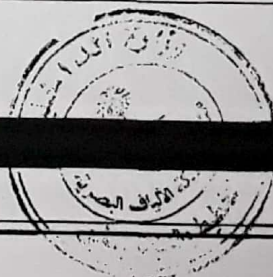

Handwritten signature

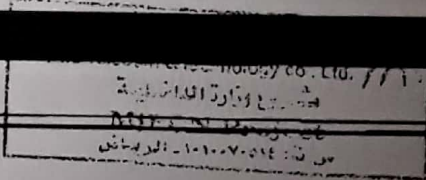



الموضوع: بشأن تأهيل شركة درة التل للمقاولات



المكرمين/ شركة درة التل للمقاولات

ص.ب: ١٠٧٠٠ الرياض: ١١٤٤٣ الهاتف: ٠١١٤٦٦٠٤٠٨ الفاكس: ٠١١٤٦٦١٠١

السلام عليكم ورحمة الله وبركاته .. وبعد

تهديكم الوكالة المساعد لمشاريع الأسكان أطيب التحايا والتقدير ، وإشارة إلى خطابكم الوارد للوزارة برقم (٤٢٠٠٨٣٣٦٤٩) وتاريخ ١١/٢٤/١٤٤٢ هـ، بشأن طلب تأهيل شركتكم في مشاريع الوزارة، وبعد الأطلاع والدراسة من قبل المختصين بالوزارة لملف التأهيل المقدم من قبلكم نفيديكم أنه لا مانع من تأهيل شركتكم لتوريد المنتجات الخرسانية مسبقة الصب كغرف التفتيش وقواعد الأنارة لمدة عامين من تاريخه على أن يتم تقديم من خلال المقاولين والمطورين المنفذين لمشاريع الوزارة مع الألتزام بما يلي عند كل تقديم:

١. شهادة هيئة المواصفات والمقاييس السعودية (SASO) عند كل تقديم.
 ٢. جميع شهادات الاختبارات لجميع المواد الموردة للمشاريع.
 ٣. سياسة وشهادة ضمان للمنتجات الموردة طبقا لمتطلبات العقد.
 ٤. الشروط والمواصفات الفنية وجداول الكميات والمخططات التعاقدية لكل مشروع.
- علماً بأن هذا الاعتماد لا يلزم الوزارة بأي منتجات لا تتوافق مع متطلبات المشاريع التابعة لها.
وتقبلوا خالص تحياتي وتقديري

الوكيل المساعد لمشاريع الإسكان

المهندس. نايف بن يوسف أبابطين

SUBMITTAL NO.: METS/NG-4094/C-21/17/R1

PROJECTS DEPARTMENT - EAST
PROJECTS DIVISION - AL HASSA



REVIEW OF CONTRACTOR'S SUBMITTAL

Use Prefix : C - Civil, M - Mechanical, E - Electrical, S - SCADA, CM - Communication, SF - Safety

PROJECT TITLE: Conversion of 115kV OHTL Between "Hameediyah\UYun\HIE" To U/G Cables, in Al-Hassa Area

CONTRACT NO. : : 4400004094/00 J.O.No: 1-1233075.02, 1-1333068.05

TO : PROJECTS DIVISION AL-HASSA FROM : (Contractor)
Al-Hassa, Service Centre Middle East Technical Services Est.-(METS)
P.O.Box No. 4323, Riyadh - 11491 - K.S.A

ACCEPTANCE OF THE FOLLOWING SUBMITTAL IS HEREBY REQUESTED :

Drawings/Sketch Materials/Equipment Others (Specify) :

FILL ALL THE REQUIRED INFORMATION BELOW :

Submittal Title : Communication Hand Hole and Manhole
(Pls,Find attach)
Reference Specification/Drawing : PTS- 13EC110
Manufacturer / Supplier Name : Dorat Al Tal EST
Manufacturer / Supplier Address :
Contact Person Name & Tel No. :

COMPLYING WITH SPECIFICATION(S) ? YES NO

Submitted By (Contractor)
Signature :
Name : Engr. Anwar Al-Hams
Title : Project Manager
Date : 4-Jan-17

Received By Sr.Transmission Engineer,PD-E/PD-H
Signature :
Name : Engr. Perry.C.Gahob
Date : Project Engineer 08/01/17
AL-HASSA PROJECT DIVISION

FOR NATIONAL GRID -SA USE ONLY

PD AL-HASSA HAS REVIEWED THIS SUBMITTAL AND FOUND IT :

ACCEPTABLE
 ACCEPTABLE, AS NOTED
 NOT ACCEPTABLE (RESUBMIT)
 CORRECT AND RESUBMIT
 PROVIDE ADDITIONAL INFORMATION
 COMPLY WITH THE COMMENTS

Sr. Transmission Engineer,PD-E/PD-H
Signature :
Name : Engr. Jawad M. Al Khamees
Title : Transmission Engineering Specialist, PMP
Al Hassa Project Division
Date : 16.01.2017

REMARKS :
Communication Handhole
Standard Drawings
(TB-800076 & TB-800077) &
SB-036373 to be followed
and shall be traffic type
cast iron cover shall be
submitted for review & approval.

Received By Signature :
(Contractor) Name :
Date :

NOTE : Acceptance does not release the Contractor from performing the Work in strict conformance with Contract Drawings and Specifications

CONSOLIDATED TRANSMISSION AREA PROJECTS DEPARTMENT
Support Facility Project Division



REVIEW OF CONTRACTOR'S SUBMITTAL

Use: C - for Civil, B - for Electrical, M - for Mechanical, CM - for Communication, S - for SCADA and SF - for Safety.

Submittal No.	C/015 Rev.0	Date	18.06.2011
PROJECT TITLE : Installation of 115kV U/G Cables to DIE 6A & Attakhassusy Substations and 132kV U/G Cables to Sakaka-C Substation			
CONTRACT No. :	30931054/00	BI No. :	
		JO No.:	1-0933076.01 1-0933078.01
To : CTAPD/EL & TPD RM 2-200E, SEC-EOA HQS, Dammam		From : SIEMENS LTD.	

ACCEPTANCE OF THE FOLLOWING SUBMITTAL IS HEREBY REQUESTED:

Check in the Drawings / Materials / Test Reports Others (Specify)

Appropriate Box: Sketches Equipment

FILL-UP APPLICABLE INFORMATION BELOW:

Description : SUBMITTAL OF COMMUNICATION HANDHOLE SUPPLIER
DORAT AL TAL ESTABLISHMENT
Project Portions 1: 115kV U/G Cables in DIE
Project Portions 2: 115kV U/G Cables in Attakhassusy

Reference Specification : PTS 08EC115 / PTS 08EC145

Manufacturer/Supplier : DORAT AL TAL EST.

Vendor Address : RIYADH

Expected Delivery Time :

COMPLYING WITH SCOPE OF WORK AND TECHNICAL SPECIFICATIONS? YES NO
IF "NO" INDICATE DEVIATIONS : (Provide justification and attach supporting documents)

<p>(Contractor)</p> <p>Submitted by : Project Manager <i>[Signature]</i></p> <p>Signature : <i>[Signature]</i></p> <p>Name : Erwin Tagaban</p> <p>Date : 18.06.2011</p>	<p>(SEC)</p> <p>Received by: Project Engineer, CTAPD/SFPD</p> <p>Signature : <i>[Signature]</i></p> <p>Name : HUSAIN I. AL-AWAMI</p> <p>Date : 19.06.2011</p>
--	--

FOR SEC USE ONLY**

<p>SEC HAVE REVIEWED THE ABOVE SUBMITTAL AND FOUND IT:</p> <p><input type="checkbox"/> ACCEPTABLE</p> <p><input checked="" type="checkbox"/> ACCEPTABLE, AS NOTED</p> <p><input type="checkbox"/> NOT ACCEPTABLE (RESUBMIT)</p> <p><input type="checkbox"/> PROVIDE ADDITIONAL INFORMATION</p> <p><input type="checkbox"/> SEE ATTACHED COMMENTS</p> <p>TES / Group Leader, CTAPD/EL & TPD</p> <p>Signature : <i>[Signature]</i></p> <p>Name : BASEM A. AL-GHAZWI</p> <p>Date : 21/06/2011</p>	<p>REMARKS :</p> <p>Communication Handhole standard (T.B. 8000.7.6 & T.B. 8000.7.7) need to be followed.</p> <p>Please use extra sheets if needed.</p> <p>Received by (Contractor) Signature : <i>[Signature]</i></p> <p>Name : Erwin Tagaban</p> <p>Date : 21/6/2011</p>
---	---

SEC - EOA/COA INTERNAL REFERENCES (FOR CTAPD USE ONLY)

Reference: _____ Dated: _____

NOTE : Acceptance does not release the Contractor from his responsibilities in performing the work in strict conformance with Contract, Scope of Work and Technical Specifications.

Exhibit 3.22
Contractor's Request for Review of Submittals

REVIEW OF CONTRACTOR'S SUBMITTAL

Use Prefix : C - Civil, M - Mechanical, E - Electrical, S - SCADA, CM - Commuincation, SF - Safety

Submittal No.:	HAIF/NG/AL-UQAIR-A/C-022/18	Date:	13 AUG 2018
----------------	-----------------------------	-------	-------------

PROJECT TITLE : Installation of 115kV U/G Cables for the Integration of Al Uqair-A 115/13.8kV S/S

CONTRACT NO. : 4400004382/00 BI No. _____ J. O. NO.: 3-1313003.04

TO : THE PROJECT ENGINEER National Grid SA, PD-East/PD- Al-Hassa Al-Hassa Service Center (SVC), K.S.A Tel No.: 013-5369787 Fax No.: 013-5369788	FROM : (Contractor) HAIF BIN MOHAMMED BIN ABBOUD AL QAHTANI & ASSOCIATES FOR TRADING AND CONTRACTING CO. P.O.Box 21, Khamis Mushayt, 61961 K.S.A.
--	--

ACCEPTANCE OF THE FOLLOWING SUBMITTAL IS HEREBY REQUESTED

Check in the Drawings/ Materials/ Test Report Others (Specify) _____

Appropriate Box Sketches Equipment

FILL ALL THE REQUIRED INFORMATION BELOW :

Description : TECHNICAL PROPOSAL FOR CAST IRON COVERS & FRAMES FOR DORAT AL TAL PRECAST CONCRETE COMMUNICATION HANDHOLES, LINK BOX PIT AND GROUNDING PIT (IN COMPLIANCE TO NG PD-E/PD-H LTR. # 18-11908-30303401)

Reference Specification/Drawing : PTS-13EC1021

Manufacturer / Supplier Name : MUNIF AL NAHDI GROUP - METAL INDUSTRIES DIVISION

Manufacturer / Supplier Address : P.O. BOX 22287, JEDDAH 21495 K.S.A. Tel. # 966-12-6081268

Expected Delivery Time :

COMPLYING WITH SCOPE OF WORK AND TECHNICAL SPECIFICATION(S) ? YES NO

IF "NO" INDICATE DEVIATIONS:(Provide justification and attach supporting documents)

(Contractor) Submitted By: Project Manager Signature :  Name : Engr. Mostafa Ahmed (A) Date : 13 AUG 2018	(NG) Received By: Project Engineer Signature :  Name : Shahid Hussain Date : 13/08/18
--	--

FOR NG-USE ONLY

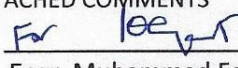
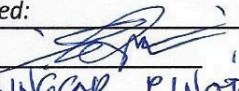
<p>NG HAVE REVIEWED THE ABOVE SUBMITTAL AND FOUND IT :</p> <p><input type="checkbox"/> ACCEPTABLE</p> <p><input checked="" type="checkbox"/> ACCEPTABLE, AS NOTED</p> <p><input type="checkbox"/> NOT ACCEPTABLE (RESUBMIT)</p> <p><input type="checkbox"/> PROVIDE ADDITIONAL INFORMATION</p> <p><input type="checkbox"/> SEE ATTACHED COMMENTS</p> <p>Signature :  Name : Engr. Muhammad Fahad Al-Mulhim Title : Project Engineer Date : 16/08/2018</p>	<p>REMARKS :</p> <p>Refer to attached comments</p> <p>Please use extra sheets if needed:</p> <p>Received By Signature :  (Contractor) Name : KINGCAR P/NOTE Date : 16-AUG-2018</p>
--	---

Reference: _____ Dated: _____

NOTE : Acceptance does not release the Contractor from his responsibilities in performing the work in strict conformance with Contract, Scope of Work and Technical Specifications

REVIEW OF CONTRACTOR'S SUBMITTAL

Use Prefix : C - Civil, M - Mechanical, E - Electrical, S - SCADA, CM - Commuincation, SF - Safety

Submittal No.	HAIF/NG/AL-UQAIR-B/C-023/18	Date:	13 AUG 2018
PROJECT TITLE	: Installation of 115kV U/G Cables for the Integration of Al Uqair-B 115/13.8kV S/S		
CONTRACT NO.	: 4400004381/00	BI No.	J. O. NO.: 3-1313003.06
TO :	THE PROJECT ENGINEER National Grid SA, PD-East/PD- Al-Hassa Al-Hassa Service Center (SVC), K.S.A Tel No.: 013-5369787 Fax No.: 013-5369788	FROM :	(Contractor) HAIF BIN MOHAMMED BIN ABOUD AL QAHTANI & ASSOCIATES FOR TRADING AND CONTRACTING CO. P.O.Box 21, Khamis Mushayt, 61961 K.S.A.

ACCEPTANCE OF THE FOLLOWING SUBMITTAL IS HEREBY REQUESTED

Check in the Drawings/ Materials/ Test Report Others (Specify) _____
Appropriate Box Sketches Equipment

FILL ALL THE REQUIRED INFORMATION BELOW :

Description : **TECHNICAL PROPOSAL FOR CAST IRON COVERS & FRAMES FOR
DORAT AL TAL PRECAST CONCRETE COMMUNICATION HANDHOLES,
LINK BOX PIT AND GROUNDING PIT
(IN COMPLIANCE TO NG PD-E/PD-H LTR. # 18-11908-30303401)**

Reference Specification/Drawing : **PTS-13EC1022**

Manufacturer / Supplier Name : **MUNIF AL NAHDI GROUP - METAL INDUSTRIES DIVISION**

Manufacturer / Supplier Address : **P.O. BOX 22287, JEDDAH 21495 K.S.A. Tel. # 966-12-6081268**

Expected Delivery Time :

COMPLYING WITH SCOPE OF WORK AND TECHNICAL SPECIFICATION(S) ? YES NO
IF "NO" INDICATE DEVIATIONS:(Provide justification and attach supporting documents)

(Contractor)	(NG)
Submitted By: <i>Project Manager</i>	Received By: Project Engineer
Signature : 	Signature : 
Name : Engr. Mostafa Ahmed	Name : Shahid Hussain
Date : 13 AUG 2018	Date : 13/08/2018

FOR NG-USE ONLY**

NG HAVE REVIEWED THE ABOVE
SUBMITTAL AND FOUND IT :

ACCEPTABLE
 ACCEPTABLE, AS NOTED
 NOT ACCEPTABLE (RESUBMIT)
 PROVIDE ADDITIONAL INFORMATION
 SEE ATTACHED COMMENTS

Signature : 

Name : **Engr. Muhammad Fahad Al-Mulhim**

Title : **Project Engineer**

: **Al-Hassa Projects Division**

Date : **16/08/2018**

REMARKS :

Refer to attached comments

Please use extra sheets if needed:

Received By Signature : 

(Contractor) Name : **RINGAR PINOTE**

Date : **16-AUG-2018**

Reference: NG-INTERNAL REFERENCES(FOR PD-E USE ONLY) Dated:

NOTE : Acceptance does not release the Contractor from his responsibilities in performing the work in strict conformance with Contract, Scope of Work and Technical Specifications

ص ب 5190
الدمام 31422
المملكة العربية السعودية

هاتف: +966-3-857-2300
فاكس: +966-3-857-6060
www.se.com.sa



HV PROJECTS
Projects Department - East
Projects Division - Al-Hassa
Al-Hassa Service Centre (SVC)
Tel.: 013-5369787 | Fax: 013-5369788

18-11910-30303401
24 May 2018G
(08 Ramadan 1439H)

HAIF BIN MOHAMMED
CONTRACTING COMPANY
P.O. Box 21, Khamis Mushayt 61961
Kingdom of Saudi Arabia
Fax: (017) 2234754

Contract No. #4400004381
Al-Uqair 115/13.8 kV Substation- B Al Hassa Area
(115 kV Underground Cables Portion)

Attention: Project Manager Mr. Mostafa M. Ahmed

Subject: **Prequalification document of M/s Dorat Al -Tal Co. for Precast Concrete**

Reference : Letter No. Haif/NG/Al-Uqair-B /L-053/18 Dated 23-04-2018

With reference to the above subject and cited letter, Please be inform that National Grid-SA has reviewed Prequalification document of M/s Dorat Al-Tal Co. for precast concrete of communication handhole, link box pit and grounding pit under the captioned contract is found acceptable however standard drawings TB-00076, TB-00077 & TA-800142 R0 shall be followed and shall be traffic type. Cast iron cover shall be submitted for NG review & approval. Contractor to make sure that approved third party lab technician (INAT) shall be available during casting of precast elements.

Please note that contractor is fully responsible for any errors and for fulfillment of detailed requirements of the contract documents.

This is for your information & further necessary action.

SMS/MFM/KSH

CC : Letter File
Route : CN-4400004381/00 File # 3.2

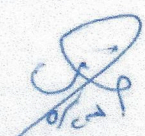
KHALID A.AL-HUMAM
Division Manager
PD-East/PD-Al-Hassa

ص ب 5190
الدمام 31422
المملكة العربية السعودية

هاتف: +966-3-857-2300
فاكس: +966-3-857-6060
www.se.com.sa



نقل الكهرباء
National Grid SA

HV PROJECTS
Projects Department - East
Projects Division - Al-Hassa
Al-Hassa Service Centre (SVC)
Tel.: 013-5369787 | Fax: 013-5369788

18-11908-30303401
24May 2018G
(08 Ramadan 1439H)

HAIF BIN MOHAMMED
CONTRACTING COMPANY
P.O. Box 21, Khamis Mushayt 61961
Kingdom of Saudi Arabia
Fax: (017) 2234754

Contract No. #4400004382
Al-Uqair 115/13.8 kV Substation- A Al Hassa Area
(115 kV Underground Cables Portion)

Attention: Project Manager Mr. Mostafa M. Ahmed

Subject: **Prequalification document of M/s Dorat Al -Tal Co. for Precast Concrete**

Reference : Letter No. Haif/NG/Al-Uqair-A/L-068/18 Dated 23-04-2018

With reference to the above subject and cited letter, Please be inform that National Grid-SA has reviewed Prequalification document of M/s Dorat Al-Tal Co. for precast concrete of communication handhole, link box pit and grounding pit under the captioned contract is found acceptable however standard drawings TB-00076, TB-00077 & TA-800142 R0 shall be followed and shall be traffic type. Cast iron cover shall be submitted for NG review & approval. Contractor to make sure that approved third party lab technician (INAT) shall be available during casting of precast elements.

Please note that contractor is fully responsible for any errors and for fulfillment of detailed requirements of the contract documents.

This is for your information & further necessary action.

SMS/MFM/KSH

CC : Letter File
Route : CN-4400004382/00 File # 3.2

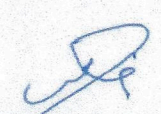
KHALID A.AL-HUMAM
Division Manager
PD-East/PD-Al-Hassa

Rev.1

Manufacturer Approval Form



1. Company: DORAT AL-TAL COMPANY FOR CONTRCTING

Product: Precast Manholes & Handholes

Location : OLAYA, MAKKAH STREET, NEAR DUNKIN DONUTS, RIYADH 11474

2. COMPANY CERTIFICATES AND PROFILE:

- | | | |
|---|---|---|
| GOSI <input checked="" type="checkbox"/> | Specilized Lab Tests Certificate <input checked="" type="checkbox"/> | Major Client Approval <input checked="" type="checkbox"/> |
| Zakat <input checked="" type="checkbox"/> | Technical Catalog <input checked="" type="checkbox"/> | Reputed consultant Approval <input checked="" type="checkbox"/> |
| Saudization Certificate <input checked="" type="checkbox"/> | 5 Years Projects References in Saudi Arabia <input checked="" type="checkbox"/> | After sales service in GCC <input type="checkbox"/> |
| Ministry of Industry <input checked="" type="checkbox"/> | Other Certificates (ISO, ASTM, ...etc.) <input checked="" type="checkbox"/> | |
| Chamber of Commerce <input checked="" type="checkbox"/> | Certificate of Origin <input checked="" type="checkbox"/> | |
| SASO <input type="checkbox"/> | Warranty Certificate <input checked="" type="checkbox"/> | |

comment:

3. Visit Report to Factory/Projects:

"To be attached"

4. Originator:

Site Supervision

Technical Team

Comments:

Name :

Signature :.....

Date :

5. Technical Team Comments: -After review submitted documents, certificates for The vendor, we accept Technically to add it, which comply MODON requiremnt in addition to global codes requirements.

Name : *Shafiq Saudgeu*
Abdulrahman Alluhaidan

Signature :..... *[Signature]*

Date : 26/12/2019

[Signature]
26/12/2019

6. Authorized By:

Name :

Signature :..... *[Signature]*

Date : 30/12/2019

7. DOCUMENT CONTROL :





Name :

Abdulwahed Alghumartz

Signature :..... *[Signature]*

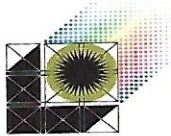
Date :...../...../.....

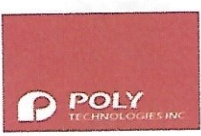
30 12 2019

ZUHAIR FAYEZ PARTNERSHIP  CONSULTANT	MINISTRY OF DEFENSE  CLIENT	POLY TECHNOLOGIES INC.  MAIN - CONTRACTOR	AL-FAHD CO. Trading, Industries and Contracting  SUB- CONTRACTOR
--	---	--	--

DOCUMENT SUBMITTAL
Supporting Buildings Project (Phase 1) – 009/56/EPC/2019 Q-5 (ZONE –A) #

SUBJECT: Precast Manhole And Poles Base (Pre-Qualification)

Specs. Code & Ref.	B.O.Q. Code Ref.	Drawing No.	Submittal No. <u>Q5-PH1-ZA-E-DC-033</u>
			Date Received: <u>22-04-2021</u>
			Date Returned: _____

Sub-contractor
 Name: AL-FAHD CO. Trading, Industries and Contracting Address: P.O. BOX 354 QASSIM -UNAIZAH
 Address: P.O. BOX 5445 RIYADH 11422 Phone: 063644555 Telex: 063645969

Manufacturer	Supplier/Agent
Name: <u>Dorat AL-Tal Co. For Contracting</u>	Name: <u>Dorat AL-Tal Co. For Contracting</u>
Address: <u>PO.BOX 10700, RIYADH 11443</u>	Address: <u>PO.BOX 10700, RIYADH 11443</u>
Phone: <u>011 – 4660408</u>	Phone: <u>011 – 4660408</u>
Fax: <u>011 – 4661016</u>	Fax: <u>011 – 4661016</u> Telex: _____

Information submitted and attached:

Certificates <input type="checkbox"/>	Operation & Maintenance Manual <input type="checkbox"/>
Technical Brochure <input type="checkbox"/>	Spare Parts List <input type="checkbox"/>
Manufacturer's Data & Specs. <input type="checkbox"/>	As Built Drawings <input type="checkbox"/>
Shop Drawings <input type="checkbox"/>	Warranty <input type="checkbox"/>
Samples <input type="checkbox"/>	Others (specify) <input type="checkbox"/>

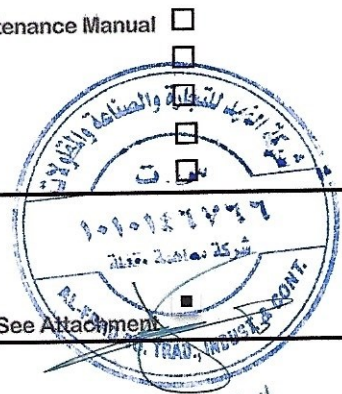



Contractor's Comments:

Note: This review does not relieve the contractor (Contractor)
 Of his responsibilities under the terms of the contract nor authorize additional compensation. Signature: ENG. MAHMOUD DAHAB
 Date: _____





Consultant's Comments:

APPROVED AS PRE-QUALIFICATION
SUBMIT TECHNICAL SUBMITTAL WITH SAMPLE
MENTION THE SPECIFIC USE AND TYPE AS PER SITE REQUIREMENTS
ATTACH WARRANTY & ALL OTHER CERTIFICATES.

See Attachment

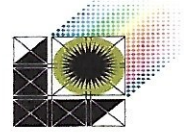
Status:	Discipline	Sign & Date	Resident Engineer	Client Note
A - Approved <input type="checkbox"/>	<input type="checkbox"/> Arch			
B - Approved as noted <input checked="" type="checkbox"/>	<input type="checkbox"/> Civil		Sign: _____	Sign: _____
C - Revise and submit <input type="checkbox"/>	<input type="checkbox"/> Mech		Date: <u>03/05/2021</u>	Date: _____
D - Rejected <input type="checkbox"/>	<input type="checkbox"/> Elect	 K.M.Wasim	Name: _____	Name: _____
E - Noted/ NA <input type="checkbox"/>	<input type="checkbox"/> HVAC	<u>03-MAY-2021</u>	<u>E-COPY</u>	
	<input type="checkbox"/> LS			

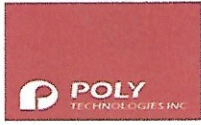
Remarks:
 1. The drawings and materials submitted by the contractor should be covered by the contract value. Any additional materials or drawings should be mentioned in the submittal.
 2. Copies and Attachments: Original (For Consultant), Copy No. (1) (For Consultant), Copy No. (2) (For Site Manager).

ZUHAIR FAYEZ PARTNERSHIP  CONSULTANT	MINISTRY OF DEFENSE  CLIENT	POLY TECHNOLOGIES INC.  MAIN - CONTRACTOR	AL-FAHD CO. Trading, Industries and Contracting  SUB- CONTRACTOR
---	--	---	---

DOCUMENT SUBMITTAL DETAILS
Supporting Buildings Project (Phase 1) – 009/56/EPC/2019 Q-5 (ZONE –A)

Submittal No. : Q5-PH1-ZA-E-DC-033

ITEM NO.	DESCRIPTION	REVIEW / APPROVAL STATUS
1	Precast Manhole And Poles Base (Dorat AL-Tal Co. For Contracting)	B

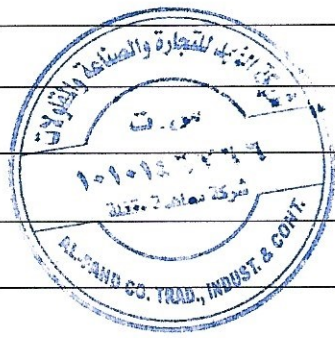

Reviewer Company Name: ZUHAIR FAYEZ PARTNERSHIP

Main Reviewer's Name: _____ Designation: _____ Signature: *Darim* Date: 03-MAY-2021

Reviewer's Name: _____ Designation: _____ Signature: _____ Date: _____

Remarks:
 1. The drawings and materials submitted by the contractor should be covered by the contract value. Any additional materials or drawings should be mentioned in the submittal.
 2. Copies and Attachments: Original (For Consultant), Copy No. (1) (For Consultant), Copy No. (2) (For Site Manager).

Attachment #3

LOCATION MAP

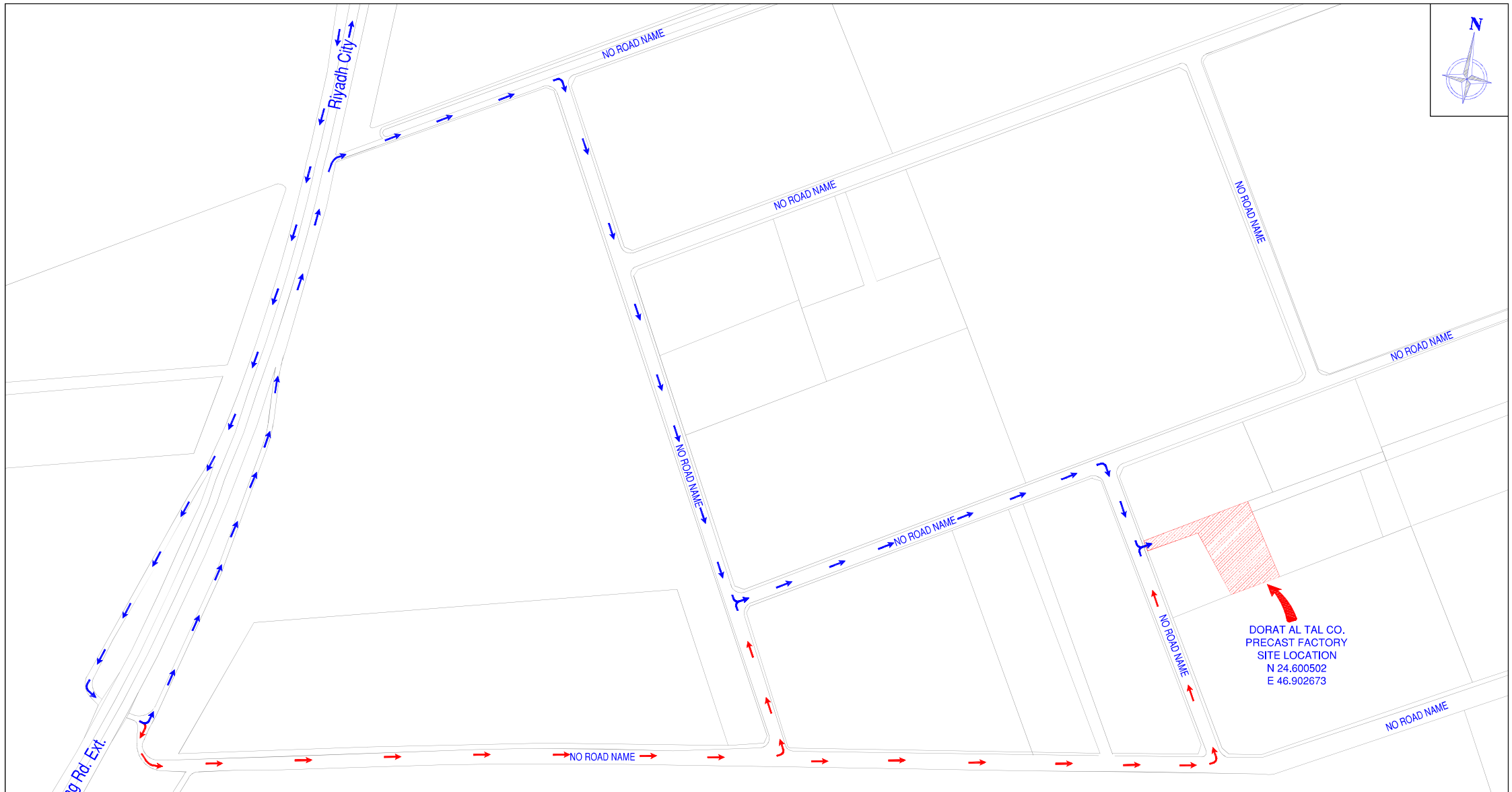
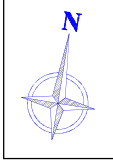

CONTRACTOR			 Dorat AL-Tal Co. For Contracting		
ENGR.: ENG. RAYYAN		PROJECT: DORAT AL TAL CO. PRECAST CONCRETE FACTORY		SCALE: SCALE	
CAD: ALEEM		TITLE: ROUTE MAP		HCR: VERT.	
REV.	DATE	SIGN.	DRAWING NO.		
1	06/12/2018		SHEET NO. 1 OF 1		
			DATE:		
			CHECKED BY:		
			APPROVED BY:		

Attachment #4

FACTORY LAYOUT

(Sulay Eastern Ring Road Exit)

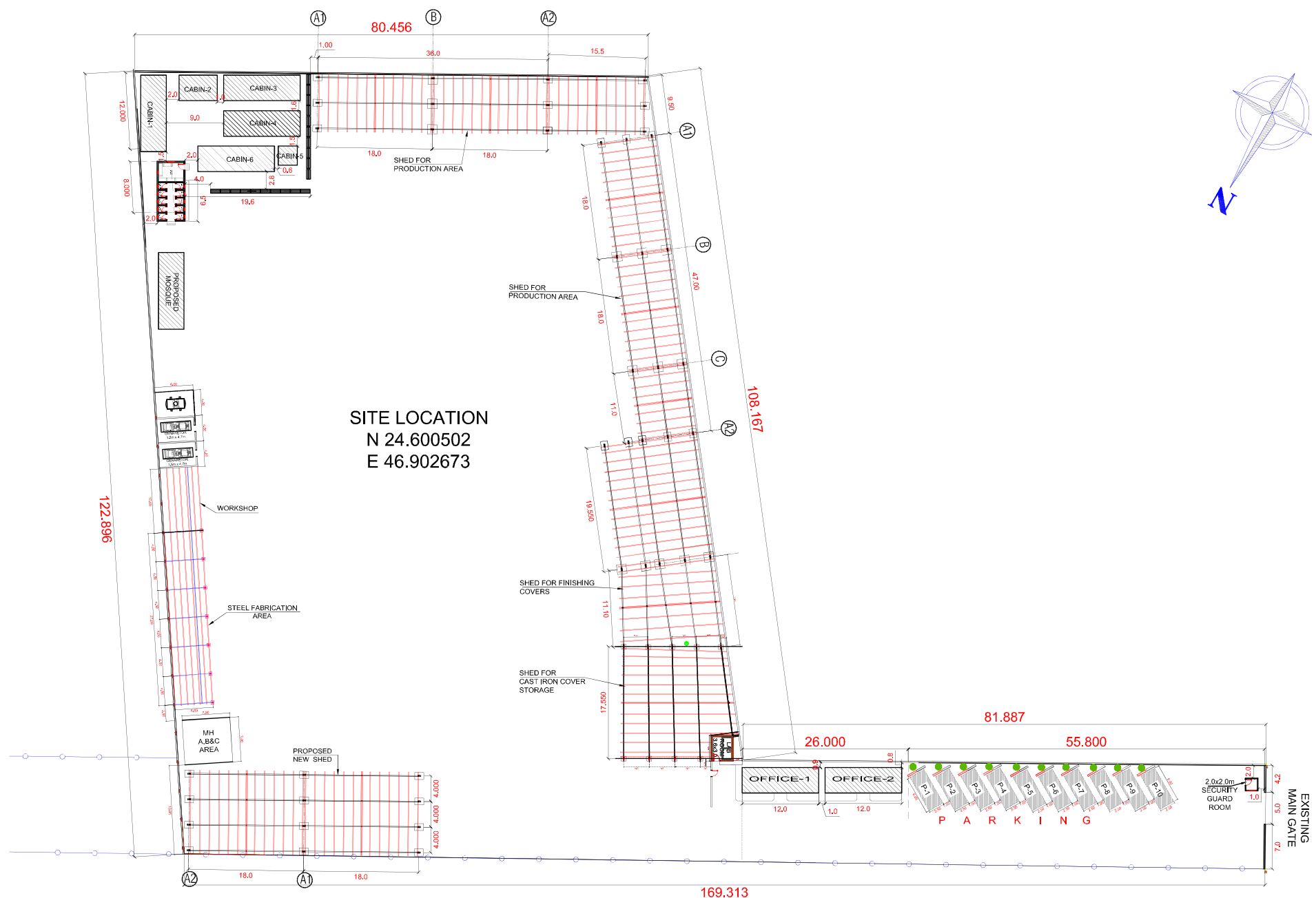
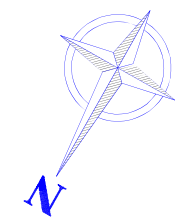

SITE LOCATION
 N 24.600502
 E 46.902673

PLAN

ENGR.:	RAYYAN	CONTRACTOR	SCALE:	SCALE
CAD:	MD.ALEEM		HOR.	
FEV.	DATE		VERT.	
	1	14/09/19	DRAWING NO.	
SIGN:			SHEET NO.	1 OF 1
			DATE:	
			CHECKED BY:	
			APPROVED BY:	
			TITLE:	DORAT AL TAL CO. PRECAST CONCRETE FACTORY

Attachment #5

QC/SAFETY MANUAL



QUALITY CONTROL And SAFETY MANUAL Precast Concrete

Prepared by: **Dorat AL-Tal Co.**

Precast Concrete Factory



Tel. No.: **011-4660408**

Fax No.: **011-4661016**

Email: dorat@dorataltal.com

P.O. Box 16829, Riyadh 11474



TABLE OF CONTENTS

	Page
COVER PAGE	1
TABLE OF CONTENTS	2
CHAPTER 1 – MATERIALS	5
1.1 CONCRETE	5
1.1.1 Cement	5
1.1.2 Aggregates	5
1.1.3 Mixing Water	5
1.2 REINFORCEMENT	6
1.2.1 Reinforcing Bars	6
1.2.2 Reinforcing Wire	6
1.3 MISCELLANEOUS MATERIALS	6
1.3.1 Lifting Devices and Lifting Apparatus	6
1.3.2 Embedded Steel Shapes and Plates	7
1.3.3 Anchor Bolts	7
1.3.4 Protective Coating	7
1.3.5 Manhole Accessories	7
1.4 STORAGE OF MATERIALS	7
CHAPTER 2 – CONCRETE	8
2.1 CONCRETE MIXES	8
2.1.1 Mix Proportions	8
2.1.2 Water-Cement Ratio	8
2.1.3 Compressive Strength	9





2.2	BATCHING AND MIXING.....	9
2.2.1	Requirements for Batching and Mixing.....	9
CHAPTER 3 – FORMWORKS, EMBEDDED PIPES, JOINTS.....		10
3.1	FORMWORKS.....	10
3.1.1	Design of Formworks.....	10
3.1.2	Removal of Forms	10
3.2	EMBEDDED PIPES.....	10
3.3	JOINTS.....	11
CHAPTER 4 – SAFETY PRODUCTION PRACTICES.....		11
4.1	GENERAL.....	11
4.1.1	Plant Layout.....	11
4.1.2	Housekeeping.....	11
4.1.3	Forms and Forming Equipment.....	12
4.1.4	Handling Equipment.....	12
4.2	FABRICATION OF REINFORCEMENT AND BLOCKOUTS.....	13
4.2.1	Fabrication of Reinforcement.....	13
4.2.2	Fabrication and Positioning of Blockouts.....	13
4.3	PRE-POUR OPERATIO.....	13
4.3.1	Cleaning of Forms.....	13
4.3.2	Application of Form Release Agent.....	14
4.3.3	Positioning of Reinforcement.....	14
4.3.4	Positioning of Miscellaneous Embedded Items.....	14
4.4	CASTING OF CONCRETE.....	14
4.4.1	Conveying Concrete.....	14
4.4.2	Depositing Concrete into Forms.....	14



4.4.3	Consolidating Concrete.....	15
4.4.4	Finishing Unformed Surface.....	15
4.4.5	Secondary Pours.....	15
4.5	CURING CONCRETE.....	16
4.5.1	General.....	16
4.6	STRIPPING PRODUCTS FROM FORMS.....	16
4.6.1	Minimum Strength Requirement.....	16
4.6.2	Product Damage During Stripping.....	16
4.6.3	Formed Surfaces.....	16
4.6.4	Post-Pour Inspection.....	17
4.6.5	Inspection of Repairs.....	17
4.7	MARKING, STORAGE, AND SHIPMENT OF PRODUCTS.....	17
4.7.1	Product Marking.....	17
4.7.2	Storage Areas.....	17
4.7.3	Shipment of Products.....	18
4.7.4	Final Inspection.....	18
CHAPTER 5 – PLANT SAFETY	18
5.1	SAFETY PROGRAM.....	18
5.1.1	Safety Gadgets.....	18
5.1.2	First Aid Kit	19
5.1.3	Flammable or Hazardous Materials.....	19



CHAPTER 1 – MATERIALS

1.1 CONCRETE

1.1.1 Cement

Cement shall conform to ASTM C150, "Standard Specification for Portland Cement".

Type V, sulfate-resisting cement(SRC) should be used where high sulfate resistance is needed.

1.1.2 Aggregates

Fine and Course aggregates shall conform to the requirements of ASTM C 33, "Standard Specification for Concrete Aggregates".

The maximum size of course aggregate shall be as large as practical, but shall not exceed one-fifth of the minimum thickness of the precast concrete product, or three-fourths of the clear cover between reinforcement and the surface of the product.

Uniformity of aggregate gradation is needed to maintain uniformity of concrete quality.

Fine and course aggregates should be free from deleterious substances and organic impurities that may affect the quality of concrete.

1.1.3 Mixing Water

Water used in mixing concrete shall be cleaned and free from deleterious amounts of oils, acids, alkalis, salts, organic material or other substances that may adversely affect properties of fresh or hardened concrete.



1.2 REINFORCEMENT

1.2.1 Reinforcing Bars

Steel reinforcing bars shall conform to the specification required in the design:

Reinforcing bars shall have a minimum Grade-60 conforming to

"Standard Specification for Deformed and Plain Billet – Steel Bars for Concrete Reinforcement".....ASTM A615

Other bars may be used for specific purposes if permitted by design.

Reinforcing bar suppliers shall furnish mill certificates for each shipment. Records of incoming reinforcing steel mill certificates shall be kept current on file.

1.2.1 Reinforcing Wire

Steel wire shall conform to "Standard Specification for Steel Wire, Deformed, for Concrete Reinforcement".....ASTM A496

Other wires may be used for specific purposes if permitted by design.

1.3 MISCELLANEOUS MATERIALS

1.3.1 Lifting Devices and Lifting Apparatus

Lifting devices used in precast concrete products shall be verified for capacity and shall have an adequate factor of safety for lifting and handling products taking into account the various forces acting on the device(impact).

The capacity of commercial lifting devices shall be marked on devices and operated by a well-trained operator.

Lifting apparatus such as slings, lift bars, chains, hooks, etc., shall be verified for capacity and shall have an adequate factor of safety for lifting and handling products.



1.3.2 Embedded Steel Shapes and Plates

Steel shapes and plates that are to be embedded in precast concrete shall conform to the requirements of ASTM A36, "Standard Specification for Carbon Structural Steel". Other types of steel shapes and plates may be used if the requirements are specified in the design.

Embedded steel shapes or plates exposed to moisture or other corrosive environments should be galvanized, stainless steel, or coated with suitable rust-inhibiting materials.

1.3.3 Anchor Bolts

Embedded anchor bolts shall conform to standard specifications of ASTM F1554, Grade 36. And should be galvanized.

1.3.4 Protective Coating

Apply two coats of bitumen to all exposed wall surface to earth. Approved type of protective coating shall be used.

1.3.5 Manhole Accessories

All Manhole accessories like ladder and ladder support, cable bracket and bracket support, sump cover etc., shall be hot dipped galvanized.

1.4 STORAGE OF MATERIALS

Cement and aggregates shall be stored in such manner as to prevent deterioration or intrusion of foreign matter.

Any materials that has deteriorated or has been contaminated shall not be used for concrete.



Aggregates shall be handled and stored in such a manner that segregation of particle sizes is minimized, gradations are kept within specified limits, contamination from underlying soil does not occur and cross-contamination between adjacent aggregate stock does not occur.

In addition, organic matter (such as leaves and twigs) shall not be allowed to accumulate and plants shall not be allowed to grow in aggregate stockpiles.

CHAPTER 2 – CONCRETE

2.1 CONCRETE MIXES

2.1.1 Mix Proportions

Concrete mixes shall be proportioned in accordance with ACI211.1, "Practice for Selecting Proportions for Normal, Heavyweight, and Mass Concrete. Mix proportions shall determine by qualified precast plant personnel for each combination of aggregates, cement, and water.

Adequate workability and proper consistency to permit concrete to be worked readily into the forms without excessive segregation or bleeding.

2.1.2 Water-Cement Ratio

Water-cement ratio for each mix design shall be calculated and documented. Concrete that will be exposed to freezing and thawing shall contain entrained air and shall have water-cement ratio of 0.45 or less. Concrete which will not be exposed to freezing, but which is required to be watertight, shall have a water-cement ratio of 0.48 or less if the concrete is exposed to fresh water. For corrosion protection, reinforced concrete exposed to deicer salts, brackish water, or sea water shall have a water-cement ratio of 0.40 or less.

Careful control of water going into the concrete is important to achieving consistent, high quality concrete.



Slump test to be made prior to placing of concrete. The slump of the fresh concrete mixed shall be 100 ±50mm.

2.1.3 Compressive Strength

Concrete Compressive Strength shall be minimum 4000psi(28MPa) at 28 days.

Compressive strength (7 or 28 days) of concrete shall be tested a minimum of once per week. Strength data shall be documented to ensure minimum strength requirements are met and kept on files.

2.2 BATCHING AND MIXING

2.2.1 Requirements for Batching and Mixing

1. All equipment for mixing and transporting concrete shall be cleaned.
2. All debris and other foreign materials shall be removed from spaces to be occupied by concrete.
3. Water shall be removed from place of deposit before concrete is place.
4. All concrete shall be mixed until there is a uniform distribution of materials and shall be discharged completely before mixer is recharged.
5. Ready-mixed concrete shall be mixed and delivered in accordance with requirements set forth in "Specification for Ready-mixed Concrete"(ASTM C94).
6. Job-mixed concrete shall be done in batch mixer approved type. Mixing shall be continued for at least 1-1/2 min. after all materials are in the drum.



CHAPTER 3 – FORMWORKS, EMBEDDED PIPES, JOINTS

3.1 FORMWORKS

3.1.1 Design of Formworks

Forms shall result in a final structure that conforms to shapes, lines and dimensions as required by the design drawings and specifications.

Forms shall be of a quality, substantial and sufficiently tight to prevent leakage of mortar and to prevent the product damage due to forces and vibrations.

Forms shall be properly braced or tied together to maintain position and shape.

Forms and their supports shall be designed so as not to damage previously placed concrete.

Forms shall be carefully cleaned and free from concrete build-up after each use before placing new concrete.

3.1.2 Removal of Forms

Forms shall be removed in such manner as not to impair safety and serviceability of the product. All concrete to be exposed by form removal shall have sufficient strength not to be damaged thereby.

3.2 EMBEDDED PIPES

Conduits, pipes, and sleeves of any material not harmful to concrete may be embedded in concrete as per the design approval of drawings. They shall not impair significantly the strength of concrete in the product.



3.3 JOINTS

Where a joint is to be made, the surface of concrete shall be thoroughly clean and all foreign materials, concrete debris, standing water be removed.

CHAPTER 4 – SAFETY PRODUCTION PRACTICES

4.1 GENERAL

4.1.1 Plant Layout

The physical layout of the plant shall be planned well in such that production, handling, storage, and shipment of concrete products can be done in an efficient, safe manner and minimal product damage.

The plant layout shall incorporate the following general guidelines:

1. Minimize transport distances of fresh concrete.
2. Adequate workspace to minimize accidents and hazards.
3. Avoid stripping or lifting product over personnel or equipment.
4. Prevent marking or splash on other products during casting operations.
5. Adequate storage space for materials.
6. Adequate space to strip products and perform post-pour inspection and repairs.

4.1.2 Housekeeping

Plant shall have an active housekeeping program. The purpose of the program shall be to provide a clean and safe environment so that quality precast concrete products can be manufactured efficiently.



The plant QC Inspector shall spot-check housekeeping daily.

A clean plant is also good for morale of workers, minimizes safety hazards, and generally improves production efficiently and quality.

4.1.3 Forms and Forming Equipment

Forms and forming equipment for manufacturing precast products shall be of a quality that prevents product damage due to forces and vibrations subjected to the forms.

Forms shall be carefully cleaned of concrete build-up after each use. Coatings of form release agents not be allowed to build up.

4.1.4 Handling Equipment

Equipment such as hoists, overhead crane, forklift trucks shall be used to lift and handle products which weigh less than the rated capacity of the equipment.

Inspection and maintenance records for all handling equipment must be maintained in accordance with applicable requirements.

Routine inspections should be made of all handling equipment to assure that safety is not compromised.

Worn cables and other parts should be replaced or repaired.

A well-trained or certified equipment operators shall manage the operation of equipment.



4.2 FABRICATION OF REINFORCEMENT AND BLOCKOUTS

4.2.1 Fabrication of Reinforcement

Reinforcing steel shall be fabricated in conformance with the precast concrete product tolerances and /or tolerances provided in the specifications or drawings. If no tolerances have been established, dimensional tolerances given in the "Concrete Reinforcing Steel Institute(CRSI) shall govern.

Adequate concrete cover is required in order to protect the steel against corrosion and to provide adequate structural bond between steel and concrete.

4.2.2 Fabrication and Positioning of Blockouts

Blockouts may be made of any rigid, non-absorptive material that will not harm the concrete and that can be held in place during the casting and curing of concrete. Dimensional blockout tolerances shall be specified for each product and blockout type.

Blockouts shall be held in place during casting with non-corrosive supports and not with reinforcing steel.

Or Coring holes in the hardened concrete is sometimes used instead of installing blockouts.

4.3 PRE-POUR OPERATIONS

4.3.1 Cleaning of Forms

Forms shall be cleaned after each use. Concrete, tape, and other materials adhering to the forms shall be removed.



4.3.2 Application of Form Release Agent

Form release agent shall be applied after the forms are cleaned and, if necessary, the seams sealed. Reinforcement and other items to be embedded in concrete shall be free of form release agent. Care shall be taken to avoid over-application of form release agent.

4.3.3 Positioning of Reinforcement

Reinforcing steel shall be positioned as specified by the design and concrete cover must conform to product requirements.

4.3.4 Positioning of Miscellaneous Embedded Items

Embedded items shall be positioned at locations specified in the design. Inserts, plates, weldments, lifting devices/hook and other items to be embedded in precast concrete products shall be held rigidly in place during casting operations.

4.4 CASTING OF CONCRETE

4.4.1 Conveying Concrete

Concrete may be conveyed from the mixer to the casting locations by any means that does not contaminate the concrete or cause excessive segregation. Concrete discharged directly from the mixer into the forms is permitted.

Conveying equipment shall be capable of providing a supply of concrete to place of final deposit without separation of ingredients and without interruptions sufficient to permit loss of plasticity between successive increments.

4.4.2 Depositing Concrete into Forms

Conventional concrete shall be deposited into forms as near to final location as practical keeping free fall of concrete to a minimum.



Concrete that has practically hardened or been contaminated by foreign materials shall not be deposited.

4.4.3 Consolidating Concrete

Concrete shall be consolidated in such a manner that segregation of the concrete is minimized. Vibrators used to consolidate concrete and shall have frequencies and amplitudes sufficient to produce well-consolidated concrete.

Internal vibrators shall be lowered vertically into the concrete without being forced downward until the tip of the vibrator reaches the bottom of the form or until it penetrates into a previously consolidated lift. Vibrate the concrete until air bubbles within the vibrator's field of action essentially stop coming to the surface. Do not use vibrators to move concrete laterally.

Proper use of vibrators to consolidate concrete requires trained operators.

4.4.4 Finishing Unformed Surface

Unformed surfaces of wet-cast precast concrete products shall be finished as specified.

4.4.5 Secondary Pours

For products that require secondary pours, procedures shall be established to assure that concrete cast during the secondary pour adequately bonds to the precast concrete product and becomes an integral part of the product.

The surfaces of the product against which the secondary pour is to be made should be free of laitance, dirt, dust, grease or any other material that will tend to weaken the bond between the original and new concretes. If the surface is very smooth, it should be roughened to help promote good bond.



4.5 CURING CONCRETE

4.5.1 General

Effective curing shall begin as soon as casting is completed.

Concrete shall be maintained above 55 F(13 C) and in a moist condition for at least the first 7 days after placement.

Concrete can be cured by properly spraying/ponding clean water for the first 7 days after placement to prevent excessive concrete temperatures or water evaporation that may impair required strength or the serviceability of the product.

4.6 STRIPPING PRODUCTS FROM FORMS

4.6.1 Minimum Strength Requirement

Products shall not be removed from the forms until the concrete reaches the designed compressive stripping strength or at least one-day.

4.6.2 Product Damage During Stripping

Products damaged during stripping shall be evaluated by qualified plant personnel to determine if repairs are necessary, and if so, repair is required before shipping.

4.6.3 Formed Surfaces

Formed surfaces shall be considered satisfactory if they are relatively free of air voids and honeycombed areas, unless the surfaces are required by the design to be finished.



4.6.4 Post-Pour Inspection

A post-pour inspection shall be made of each product.

After products are stripped from the forms, they shall be inspected for conformance with the design. Items to be repaired shall be classified as "major" or "minor" defects, or as honeycombed areas.

4.6.5 Inspection of Repairs

Products that require repairs of honeycombed areas or major repairs shall be inspected while repairs are made.

QC Inspector shall perform checks of repairs.

4.7 MARKING, STORAGE, AND SHIPMENT OF PRODUCTS

4.7.1 Product Marking

Products shall be marked as required by project specifications. Marking should be as follows;

1. Manufacturer Name
2. Production Date
3. Type
4. QC Inspected tag

4.7.2 Storage Areas

Areas used for storage of products shall be firm enough and level enough to avoid causing damage to stored products.

It is good practice to place in storage only products that are ready for shipment, thus minimizing product handling.



4.7.3 Shipment of Products

Trucks and other conveyances used to transport precast concrete products from the plant to the location designated by customer shall be equipped and maintained to deliver those products without damaging them to the extent that they must be repaired or rejected.

Trucks and other delivery equipment should be inspected periodically to ensure products will be delivered without damage.

4.7.4 Final Inspection

Prior to shipment, products shall be inspected to assure design conformance and proper identification.

The QC Inspector shall inspect the storage area and the stored product daily.

CHAPTER 5 – PLANT SAFETY

5.1 SAFETY PROGRAM

The plant shall have an active plant safety program. The program shall include requirements from local municipality.

The management or designated representative shall hold safety meetings with plant personnel a minimum of once every month. Attendance of plant personnel is a must.

5.1.1 Safety Gadgets

Provide plant workers all necessary safety gadgets as required in their work such as;

1. Hand gloves
2. Safety Goggles
3. Overall Uniform
4. Safety Shoes



5. Other safety tools

5.1.2 First Aid Kit

In case of minor injury, First Aid Kit should be available in the plant area for treatment of injured worker.

5.1.3 Flammable or Hazardous Materials

Flammable or hazardous materials should be kept away from the plant area. Proper segregation and keeping of materials must be observed carefully.

Workplace should maintain cleanliness for good and safe work environment.

Constant housekeeping must be observed at all times.

This Quality Control Manual is prepared by Dorat Al Tal Co. to be carefully observed and guidelines for the precast factory to achieve the above quality of the products.

Prepared by:



Attachment #6

LIST OF PROJECTS



LIST OF PROJECTS:

S.NO	CLIENT	PROJECT	TYPE OF PRECAST	Remarks
1	Saudi Telecom Company(STC)	Supply All types of Precast required by STC.	ALL TYPES OF MANHOLES/ MINI-MANHOLES/ HANDHOLES/ CABINET BASE/ MARKER POST	Dorat Al Tal Factory is Approved Supplier of STC
2	Integrated Telecom Company(ITC)	Supply All types of Precast required by ITC.	ALL TYPES OF MANHOLES/ MINI-MANHOLES/ HANDHOLES/ CABINET BASE/ MARKER POST	Dorat Al Tal Factory is Approved Supplier of ITC
3	DAWIYAT	Supply All types of Precast required by DAWIYAT.	ALL TYPES OF MANHOLES/ MINI-MANHOLES/ HANDHOLES/ CABINET BASE/ MARKER POST	Dorat Al Tal Factory is Approved Supplier of DAWIYAT
4	GPT-National Guard	Supply All types of Precast required by GPT for National Guard.	ALL TYPES OF HANDHOLES/ CABINET BASE/ MARKER POST	Dorat Al Tal Factory is Approved Supplier of GPT
5	MOI	MIFON	Supply of HH2C, HH3C, Mini-Manhole, Service Maintenance Manhole, Marker Post	Dorat Al Tal Factory is Approved Supplier of MOI
6	Saudi Electricity Company(SCECO)	Installation of 115kV U/G Cables to DIE 6A & Attakhassusy Substation and 132kV U/G Cables to Sakaka-C Substation.	Communication Handhole Standard (DWG NO. TB-800076 & 800077)	Supplied to contractor MASTOURA company.
7	National Grid Company(NG)	NG Hameediyah project & Al Uqair project	Communication Handhole and Link Box	Supplied to main contractor Middle East Technical Service Est. (METS) and HAIF Company
8	Saline Water Conversion Corporation (SWCC)	Supply of Manholes for Rass Al Khair SWCC WTS.	MANHOLES	Supplied to main contractor Weltex Saudi Arabia Ltd.
9	National Water Company(NWC)	Supply of Manholes in Riyadh project.	MANHOLES	Supplied to main contractor Weltex Saudi Arabia Ltd.
10	CALIFORNIA COMPOUND, Riyadh	New Compound Construction.	MANHOLES/HANDHOLES	Supplied all the required manholes/handholes for the new compound under construction.
11	Saline Water Conversion Corporation (SWCC)	Supply of Manholes for Taif – Al Baha SWCC WTS.	MANHOLES	Supplied to main contractor TOLEDO & Weltex Saudi Arabia Ltd.
12	Saudi ARAMCO	Supply of Telecom Manholes for Dahrhan Housing Project	MANHOLES	Supplied to main contractor AZMEEL Company





13	SABIC - JUBAIL	Supply of 3-cover Handholes.	3-Cover Handhole	Supplied to main contractor ITEA.
14	SITAF Saudia Co.	Supply of Mini manhole for CCASG/GCC project.	Mini manhole	Supplied to main contractor SITAF.
15	FAST (Riyadh Metro Project)	Supply of New Jersey Barriers for Riyadh Metro Project.	New Jersey Barriers (concrete barricades)	Supplied to contractor FAST .
16	FAST (Riyadh Metro Project)	Supply of Lintel Beams for Riyadh Metro Project.	Lintel Beams	Supplied to contractor FAST .
17	MODON	Supply Handhole two cover to SAPAC company.	2-Cover Handhole	Supplied to main contractor SAPAC.
18	NATIONAL GRID	Al Uqair Substations	Electrical & Fiber Optic Manholes	Supplied to main contractor Haif Company.
19	Saline Water Conversion Corporation (SWCC)	Riyadh New City Feeders Project	Electrical Manholes	Supplied to main contractor RTCC Company.
20	OTHERS	SPECIAL CASES.	As per client drawings	Supply different types of precast as per client drawings and requirements.



Attachment #7

Standard Drawings of Clients

Category : Civil Item Spec. No. : VM 101 Date : 06-07-2020 Issue :4	<u>Man-holes with Covers</u>	
--	------------------------------	---

4. APPENDIXES

Appendix 1: Manhole Type A – Dimensions

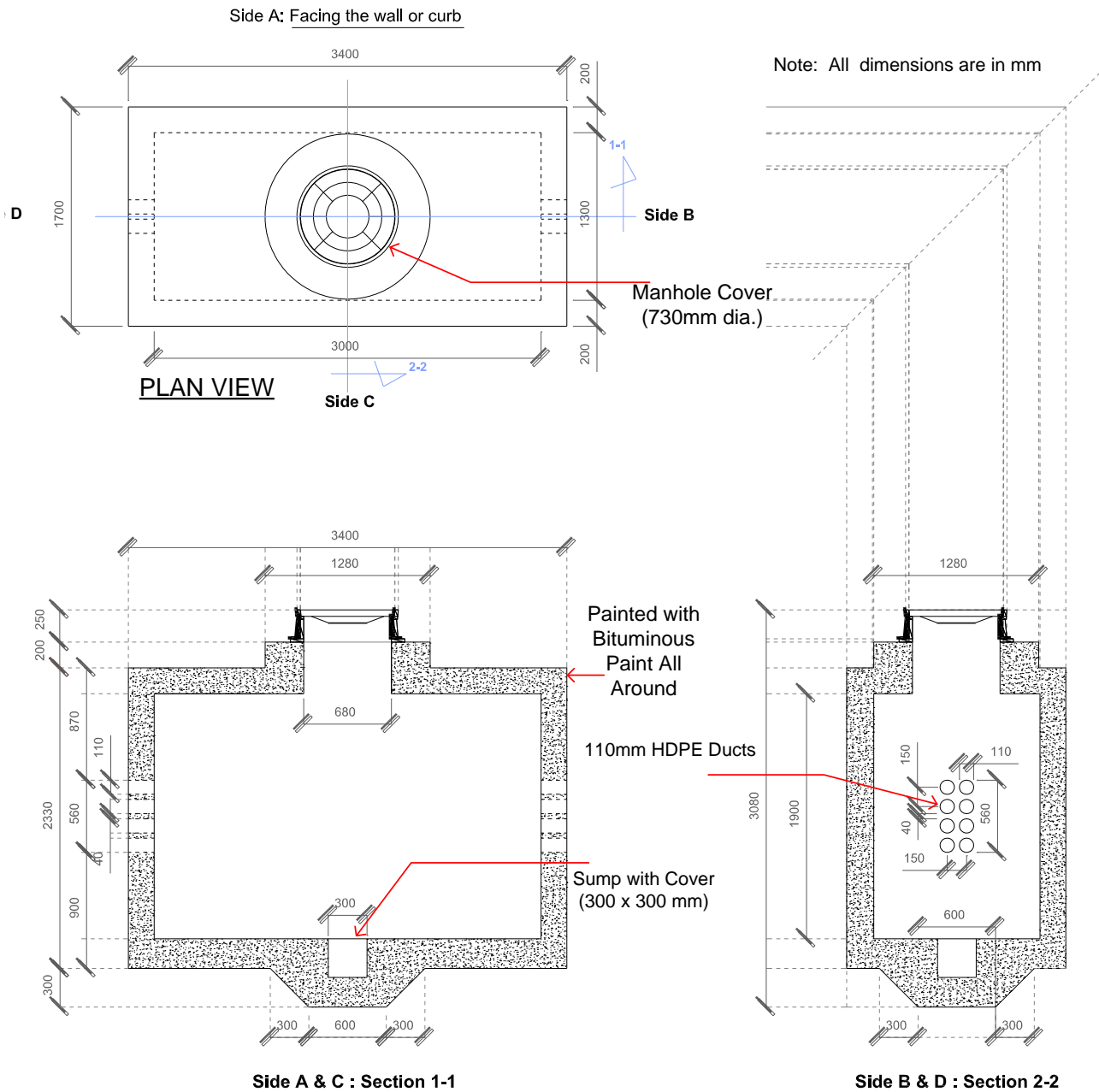

Category : Civil Item Spec. No. : VM 101 Date : 06-07-2020 Issue : 4	<u>Man-holes with Covers</u>	
---	------------------------------	---

Appendix 2: Manhole Type B – Dimensions

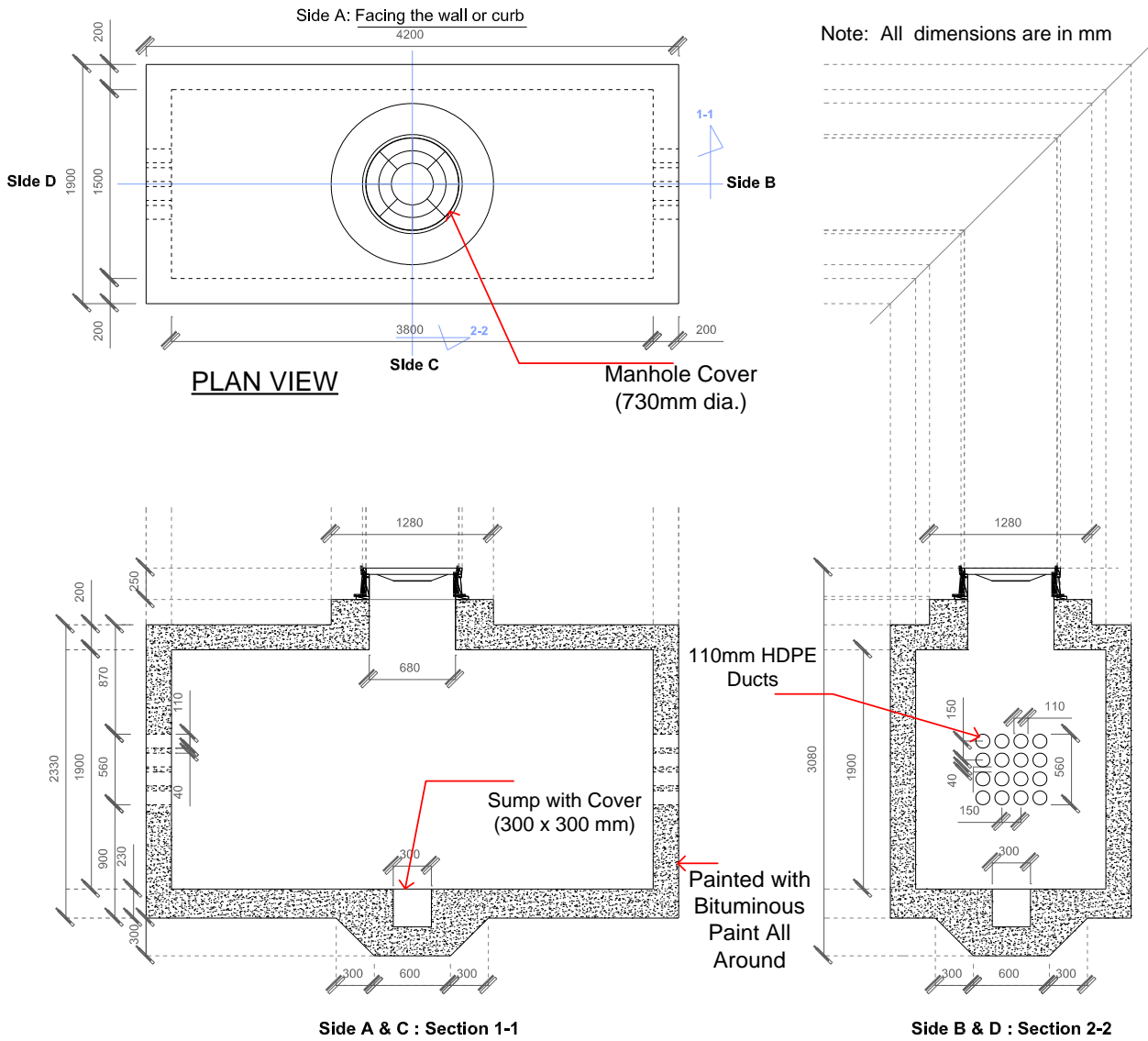

Category : Civil Item
Spec. No. : VM 101
Date : 06-07-2020
Issue : 4

Man-holes with Covers



Appendix 3: Manhole Type C – Dimensions

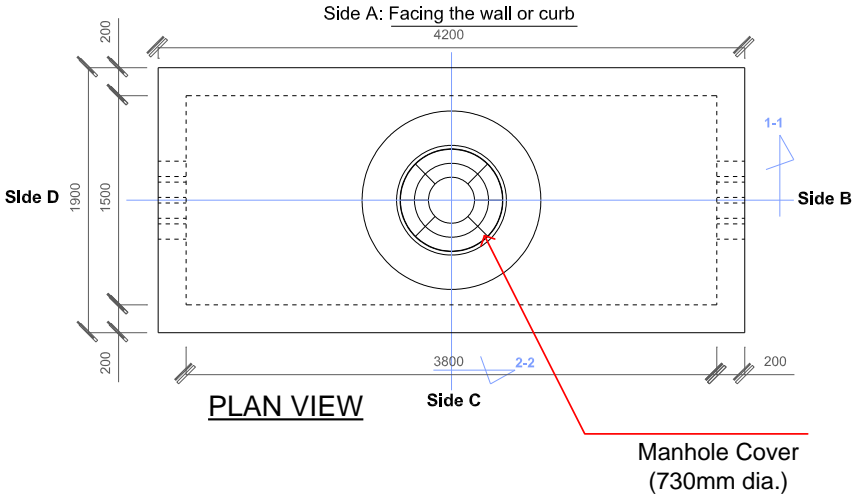

Note: All dimensions are in mm

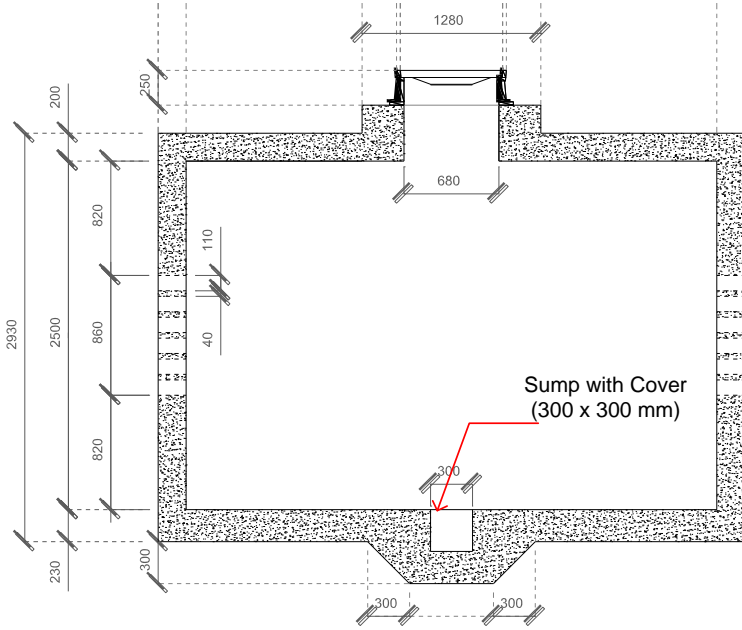

Side A & C : Section 1-1

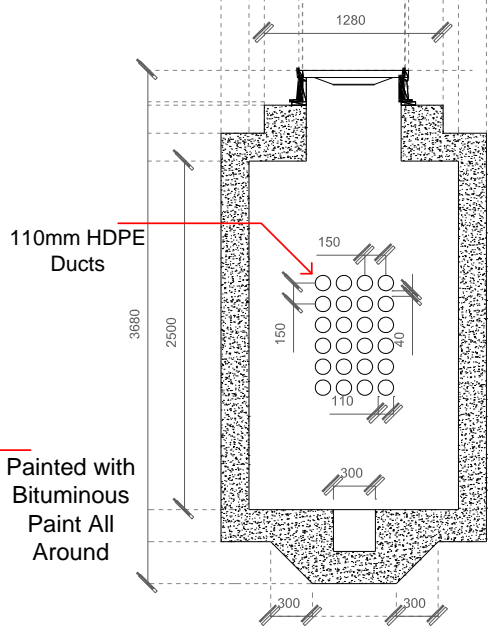

Side B & D : Section 2-2

Category : Civil Item
Spec. No. : VM 101
Date : 06-07-2020
Issue : 4

Man-holes with Covers



Appendix 4: Manhole Type D – Dimensions

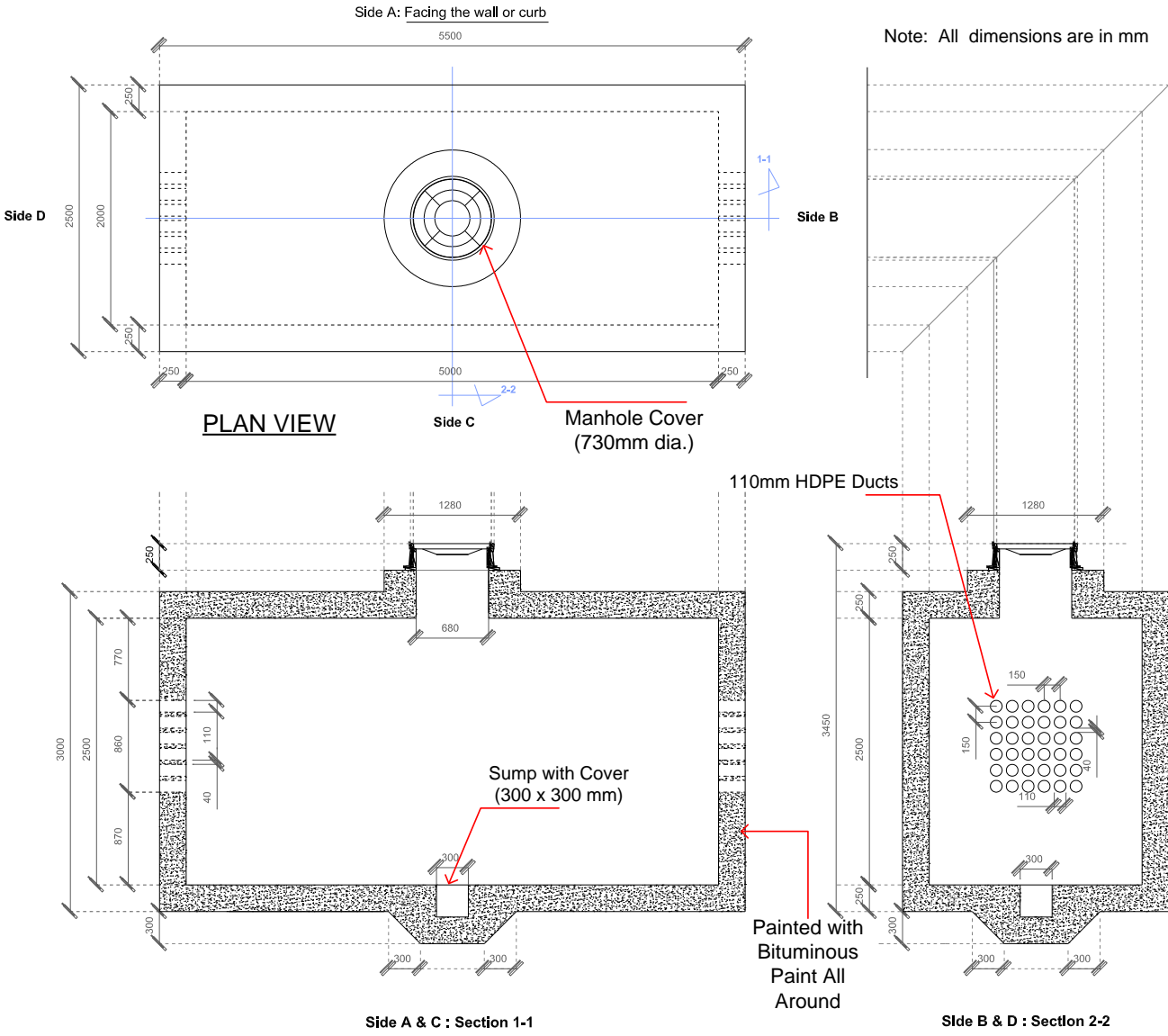

Category : Civil Item
 Spec. No. : VM 101
 Date : 06-07-2020
 Issue : 4

Man-holes with Covers



Appendix 5: Mini Manhole – Dimensions

Appendix 5-A: Mini Manhole (Standard)

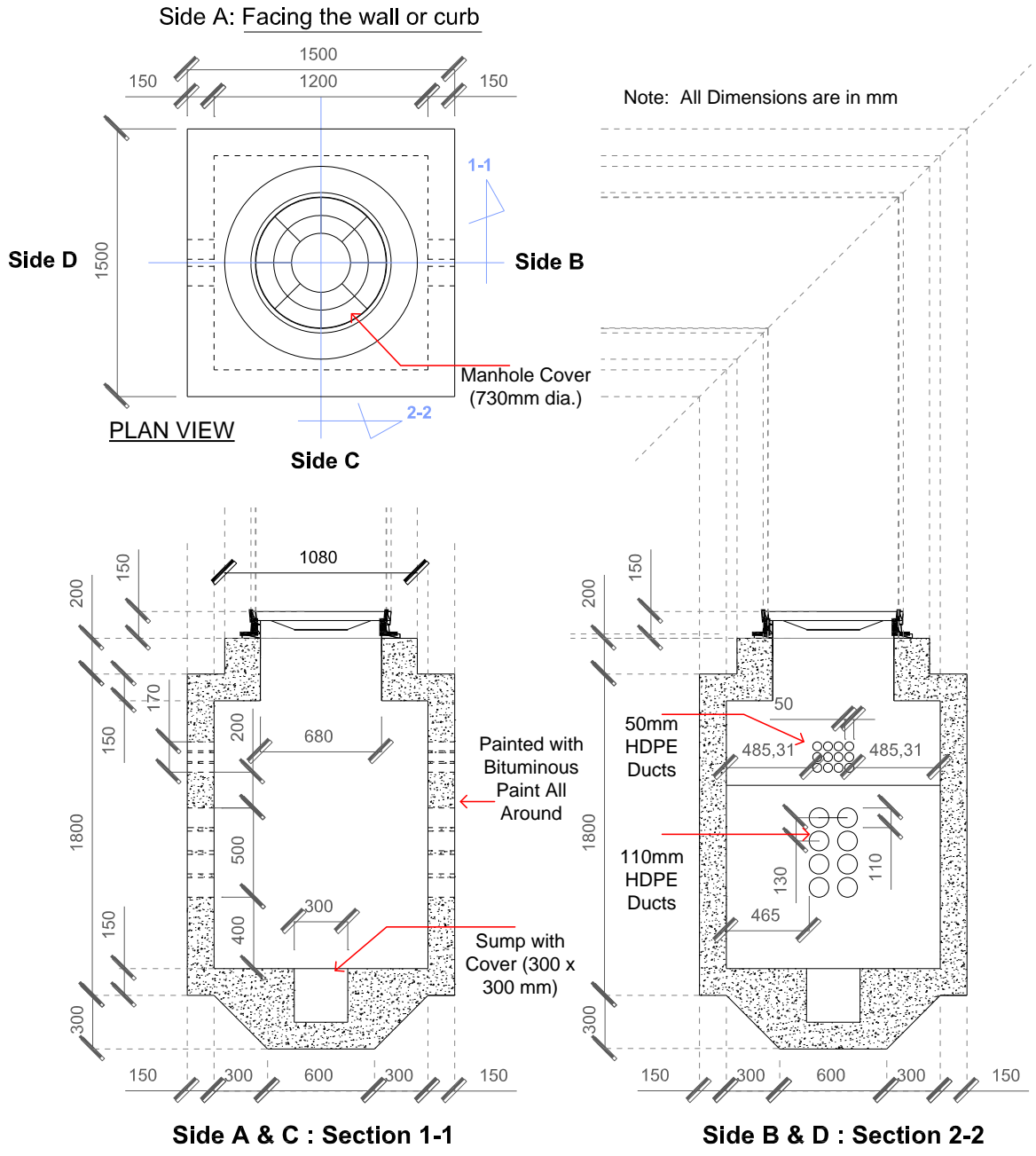

Category : Civil Item Spec. No. : VM 101 Date : 06-07-2020 Issue : 4	<u>Man-holes with Covers</u>	
---	------------------------------	---

Appendix 5-B: Mini Manhole (FTTH Project)

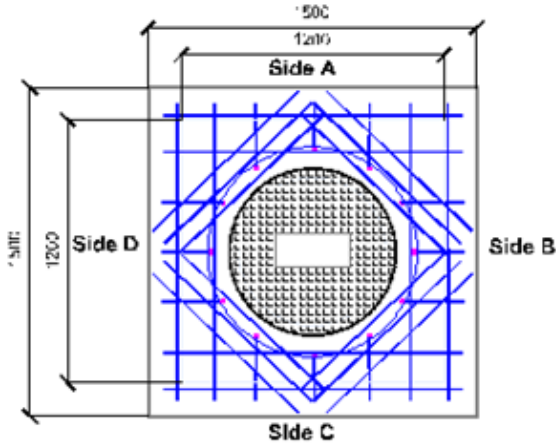

Top View

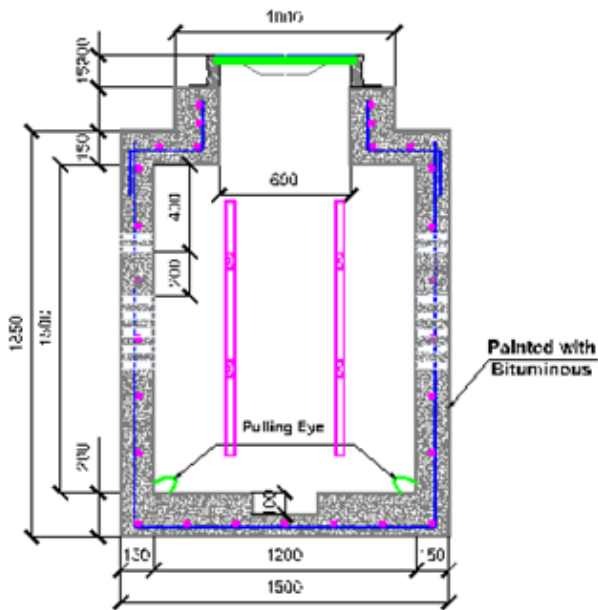

Side A-C View

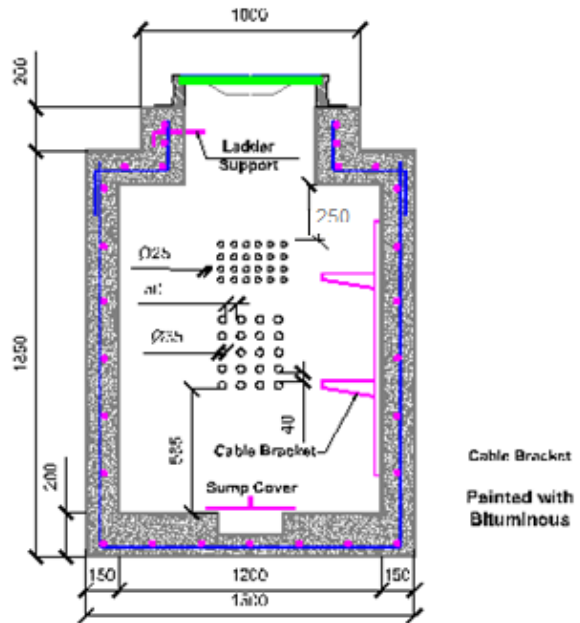

Side B-D View

Category : Civil Item Spec. No. : VM 101 Date : 06-07-2020 Issue :4	<u>Man-holes with Covers</u>	
--	------------------------------	---

Appendix 5 C : Mini manhole with knock-out window. As 5B but now with knock-out window instead of single duct-holes

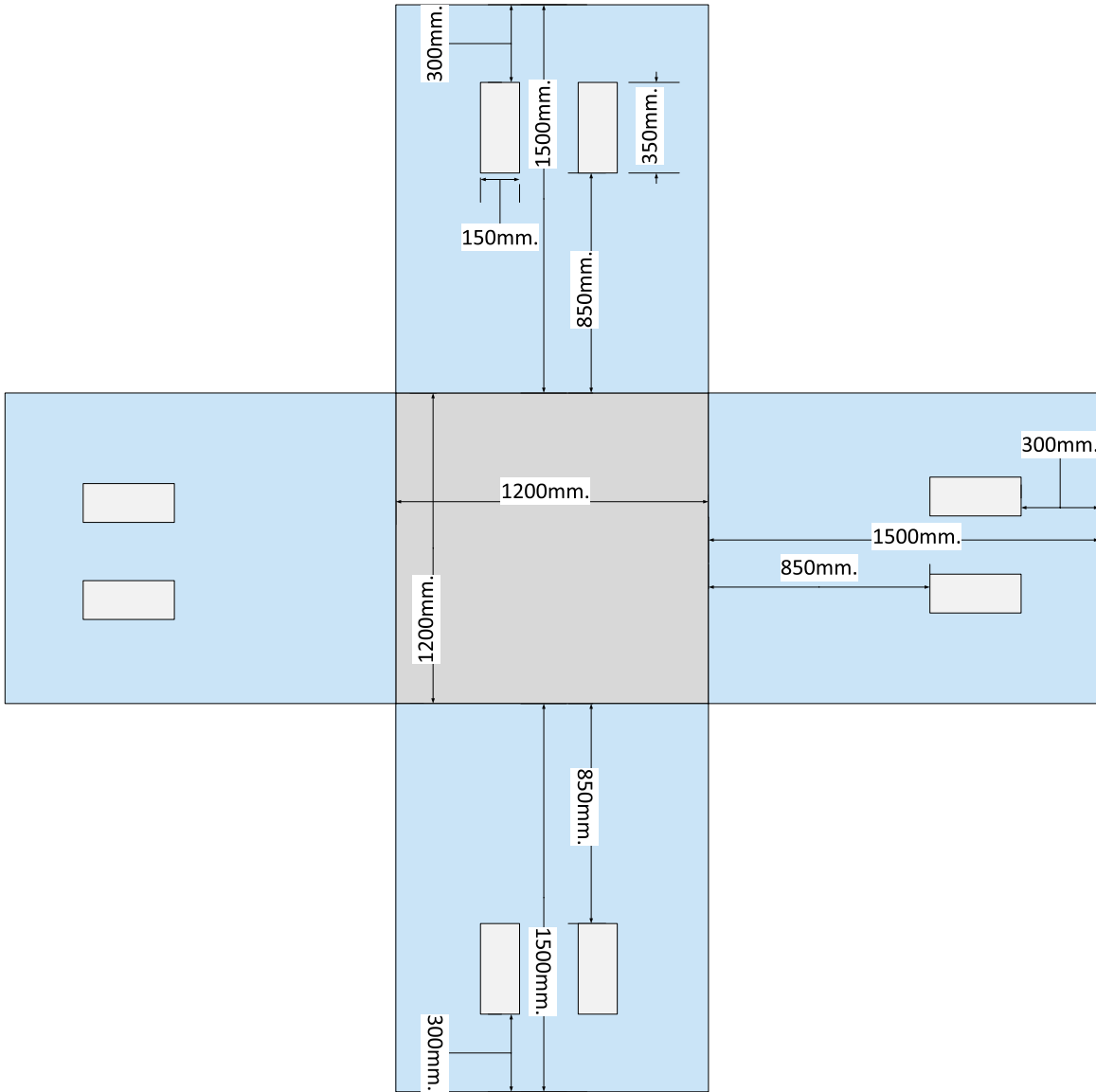

Category : Civil Item Spec. No. : VM 101 Date : 06-07-2020 Issue :4	<u>Man-holes with Covers</u>	
--	------------------------------	---

Appendix 6: Manhole Cover & Frame (operation maintenance) – Dimensions

Category : Civil Item
 Spec. No. : VM 101
 Date : 06-07-2020
 Issue : 4

Man-holes with Covers

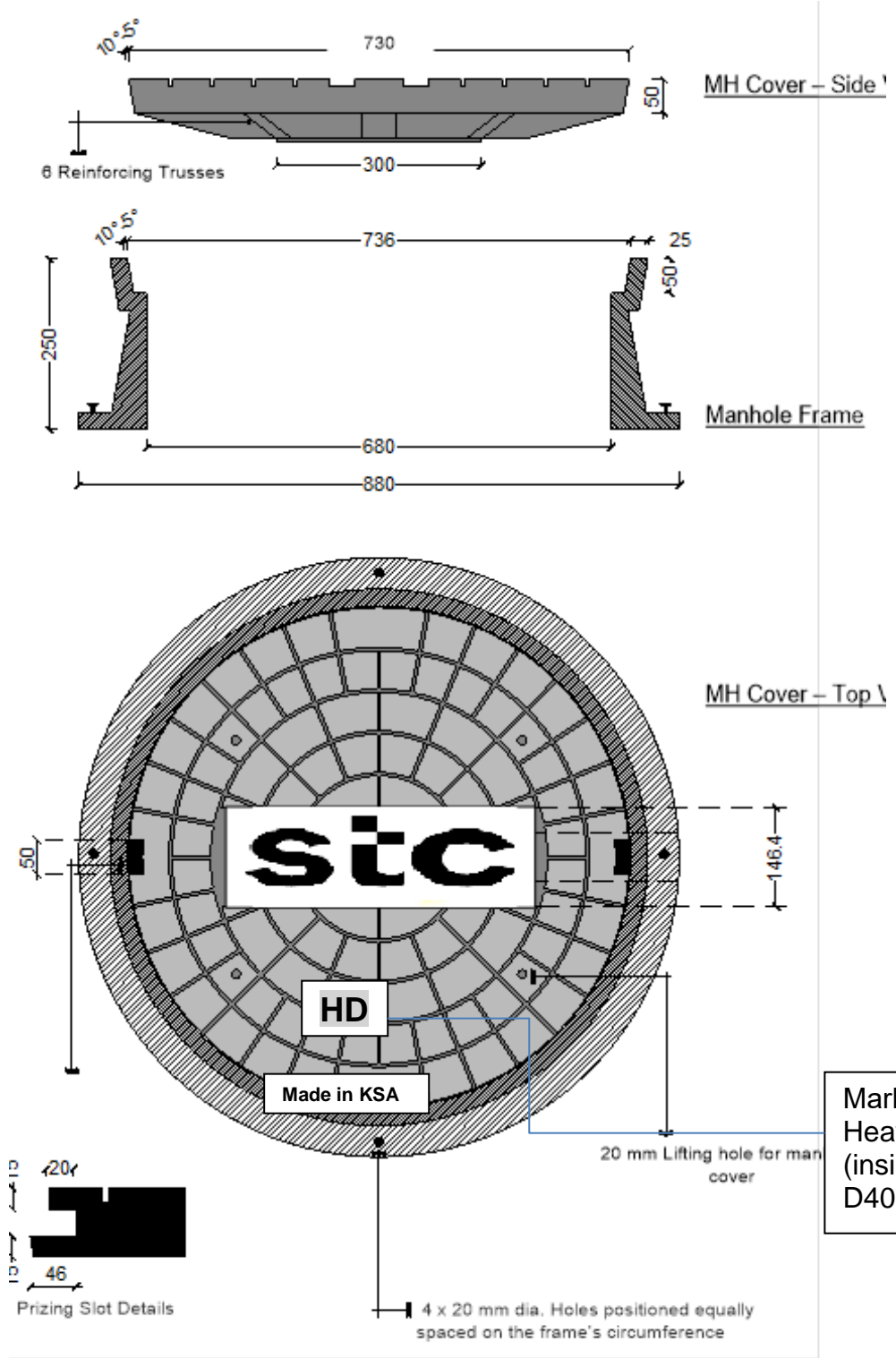

1) All dimensions are in mm.
 2) Tolerances shall be +/- 2 mm (min.) between all interfacing components; All others shall be +/- 5mm.

Appendix 7: Manhole Cover & Frame with hinges – Dimensions

Category : Civil Item
 Spec. No. : VM 101
 Date : 06-07-2020
 Issue : 4

Man-holes with Covers

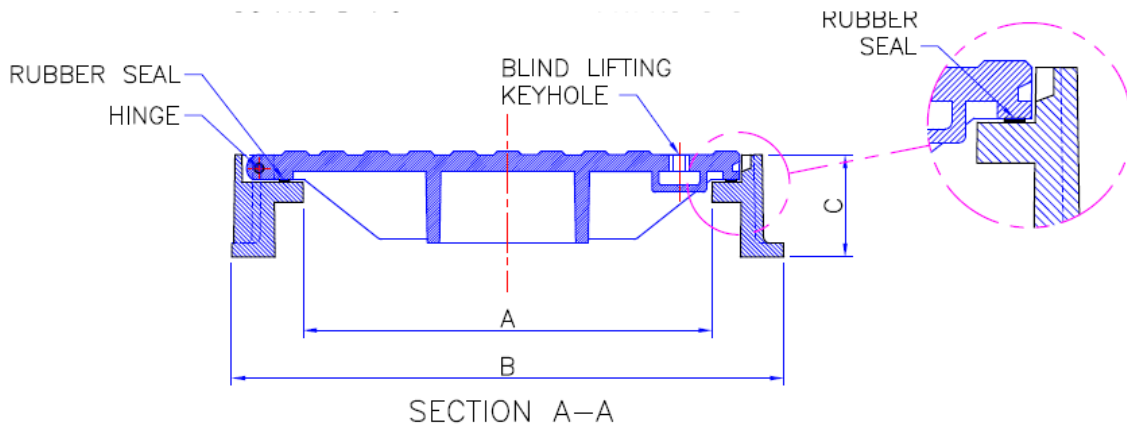
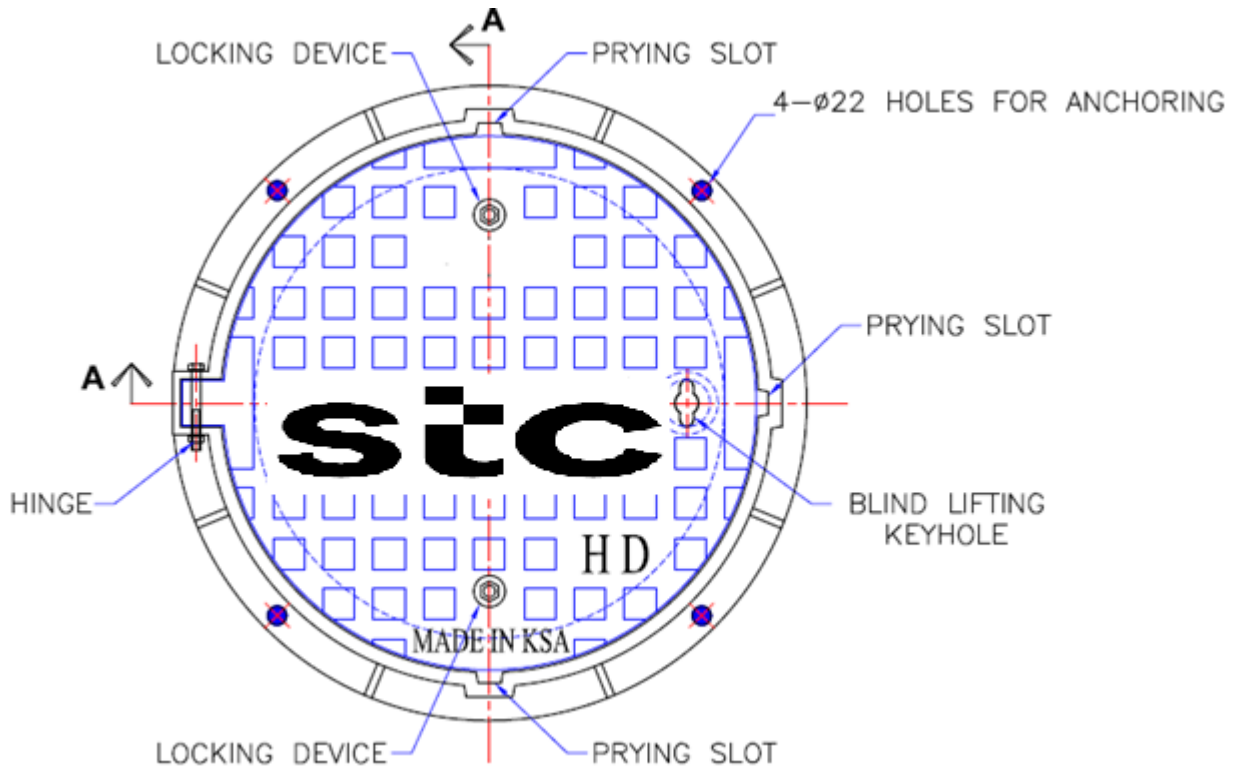

Clear Opening A(mm)	Over Base B(mm)	Depth C(mm)	Loading (Tons)	Standard
Ø600	Ø810	150	40	EN124/D400

Category : Civil Item Spec. No. : VM 101 Date : 06-07-2020 Issue :4	<u>Man-holes with Covers</u>	
--	------------------------------	---

Appendix 8: Marking Plate and QR Code :



The inserted information in clause 3.2 has to be printed clearly in the plate and appear when the QR code scanning .

For more details please see “ Design Guideline “

Category : Civil Item
Spec. No. : VM 103
Date : 6-7-2020
Issue :5

Hand-holes with Covers



4. APPENDICES

Appendix 1: Handhole Type 1 (Standard & FTTH types) 1-A: Hand hole Type 1, One Cover (Standard Type) –

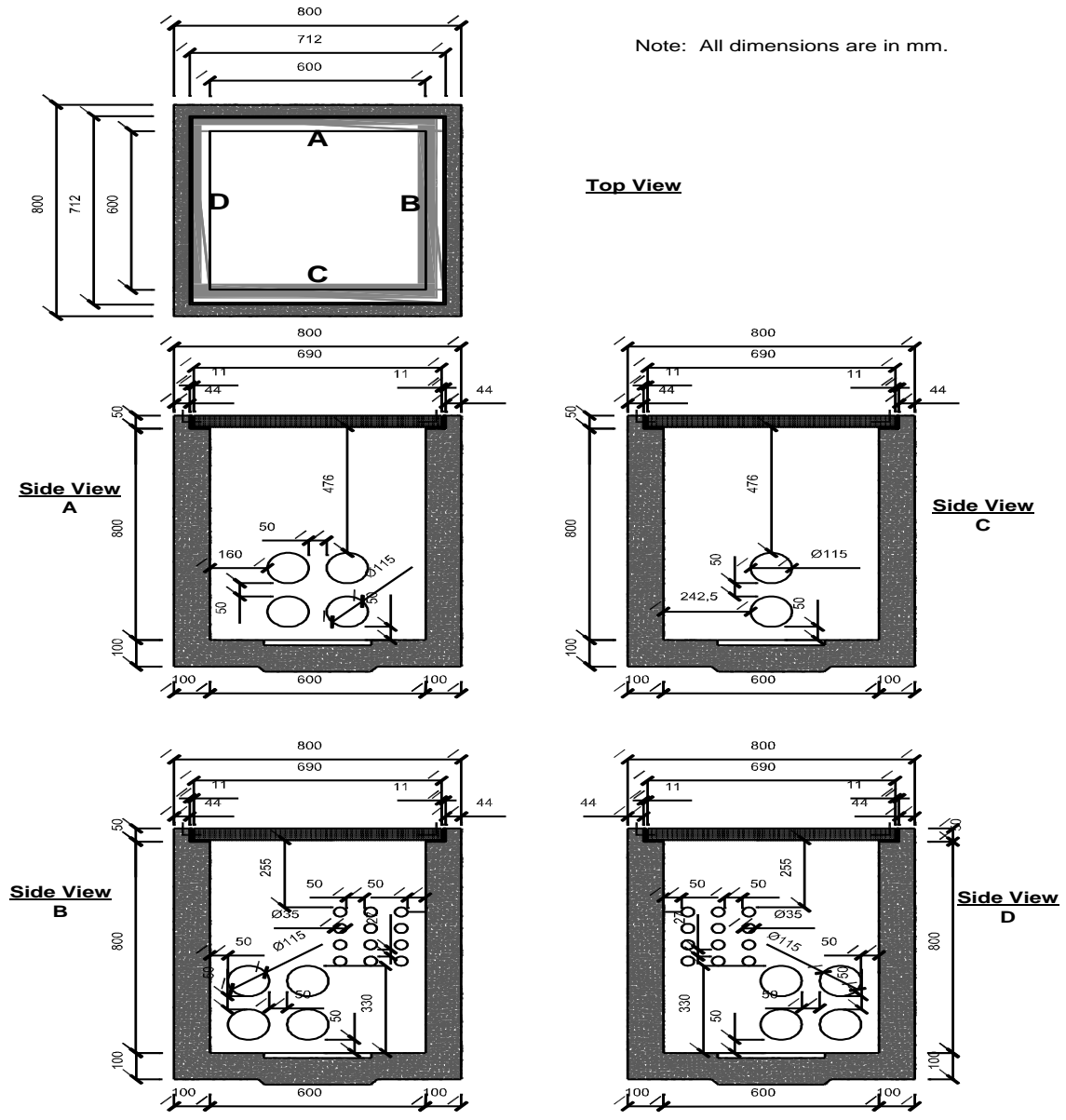

Category : Civil Item
Spec. No. : VM 103
Date : 6-7-2020
Issue :5

Hand-holes with Covers



1-B: Handhole Type 1, One Cover (FTTH Type)

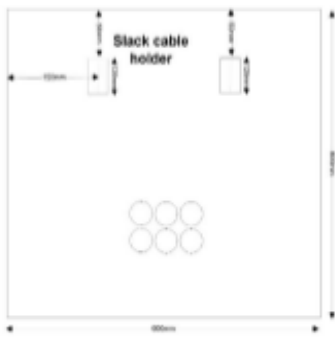
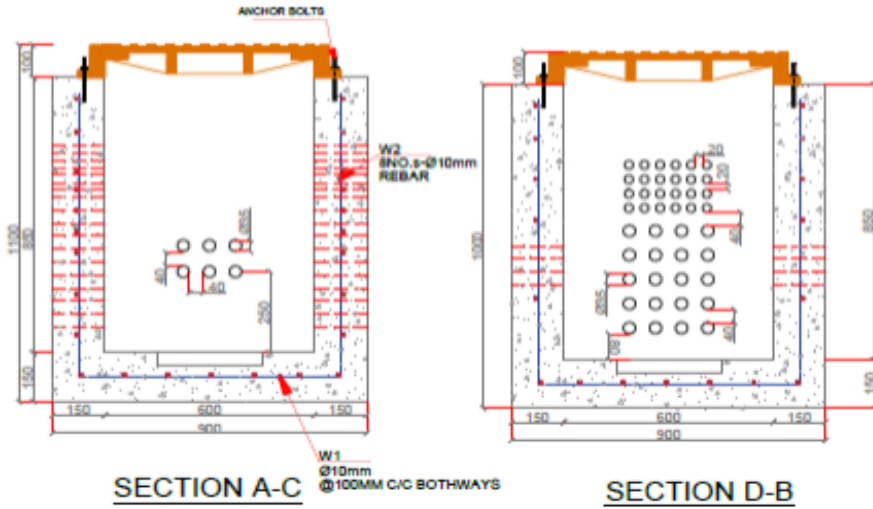
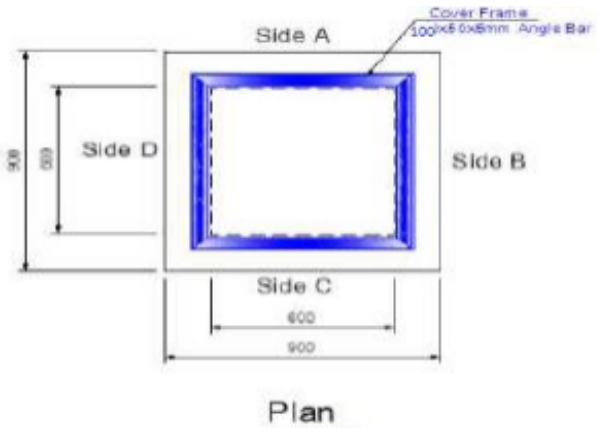

Section (A-C)
Slack Cable Holder position

Category : Civil Item
 Spec. No. : VM 103
 Date : 6-7-2020
 Issue :5

Hand-holes with Covers

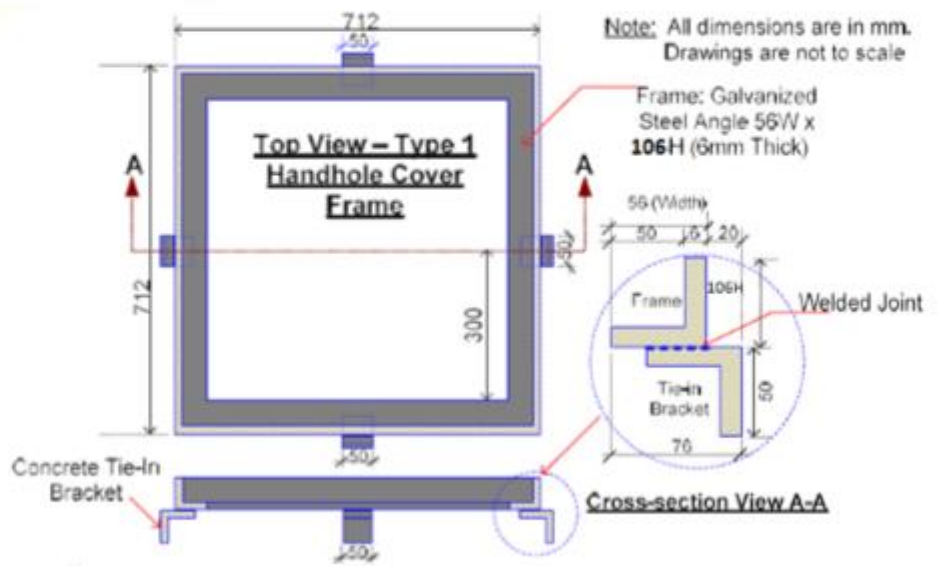
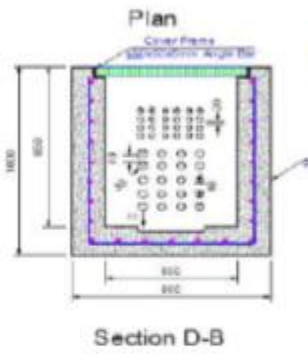
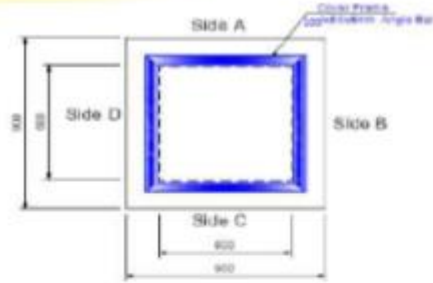

Category : Civil Item
Spec. No. : VM 103
Date : 6-7-2020
Issue :5

Hand-holes with Covers



Appendix 1-C: Handhole cover without hinges Details

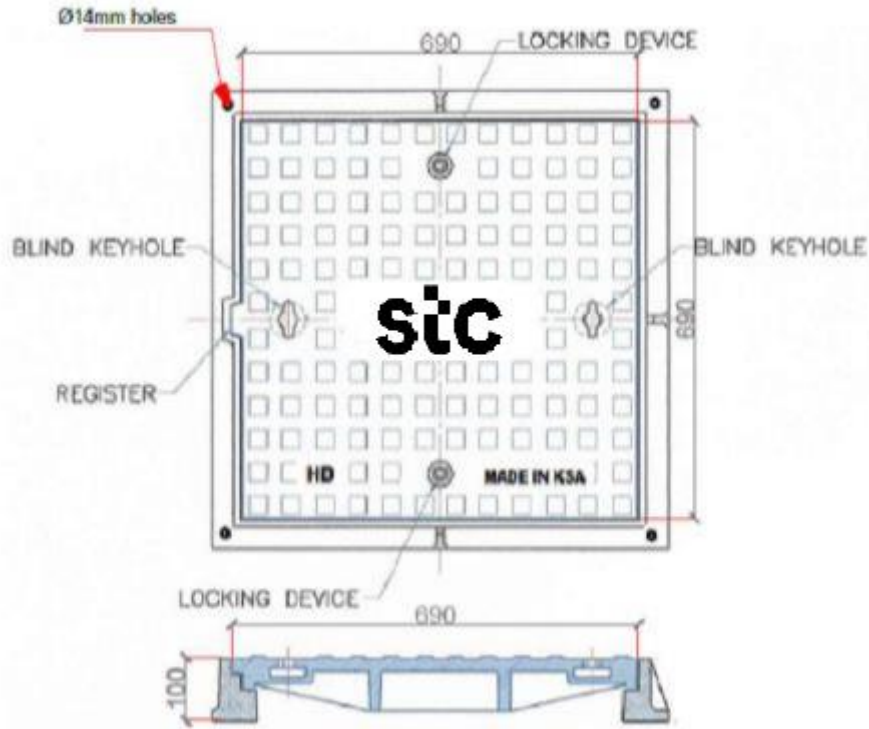

HANDHOLE COVER & FRAME

HANDHOLE COVER & FRAME

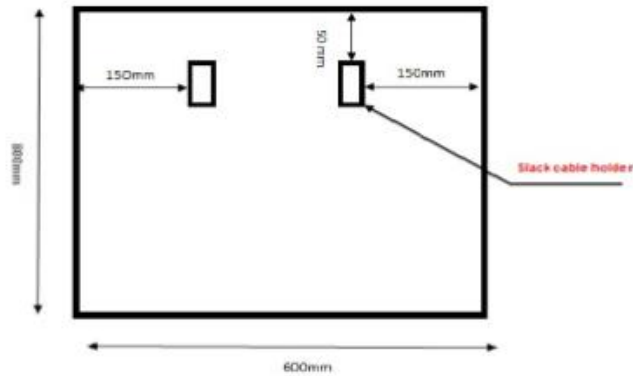

**Section (A-C)
Slack Cable Holder position**

Category : Civil Item Spec. No. : VM 103 Date : 6-7-2020 Issue :5	<u>Hand-holes with Covers</u>	
--	-------------------------------	---

1-D: Handhole Type 1, One Cover (FTTH Type Window)

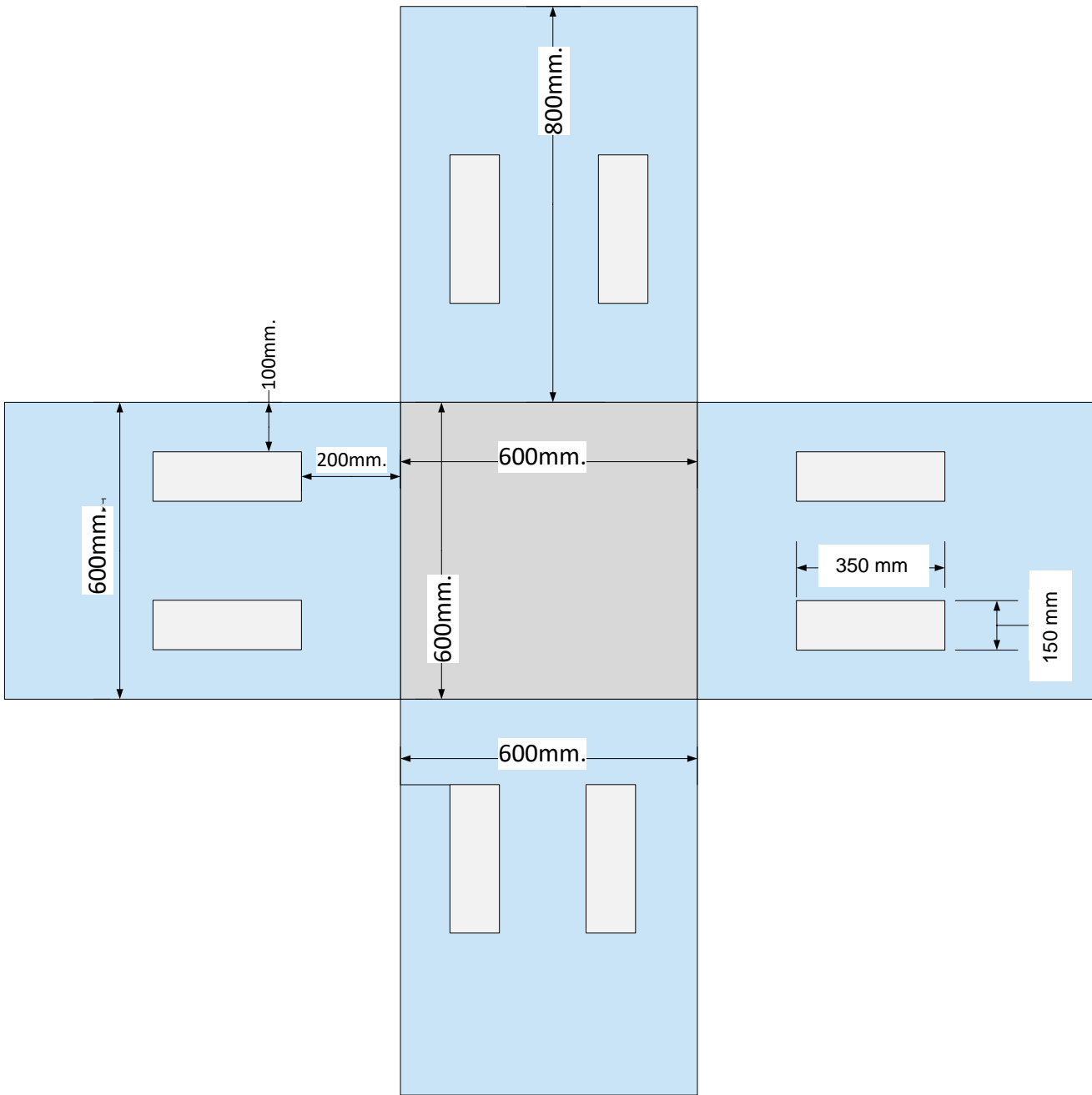

Category : Civil Item
Spec. No. : VM 103
Date : 6-7-2020
Issue :5

Hand-holes with Covers

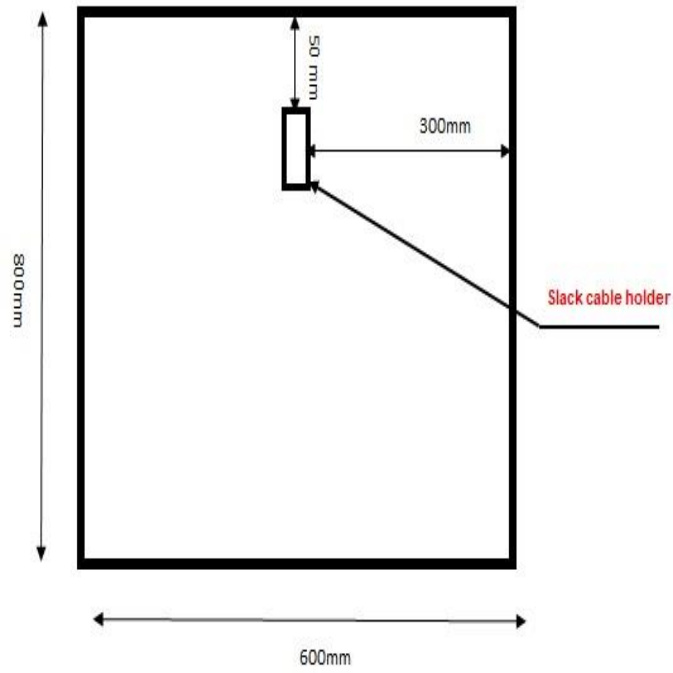

Section (A, B, C, D)
Slack Cable Holder position

Category : Civil Item Spec. No. : VM 103 Date : 6-7-2020 Issue :5	<u>Hand-holes with Covers</u>	
--	-------------------------------	---

Appendix 2: Handhole Type 2 (Standard & FTTH types)

2-A: Handhole Type 2, Two Covers (Standard Type)

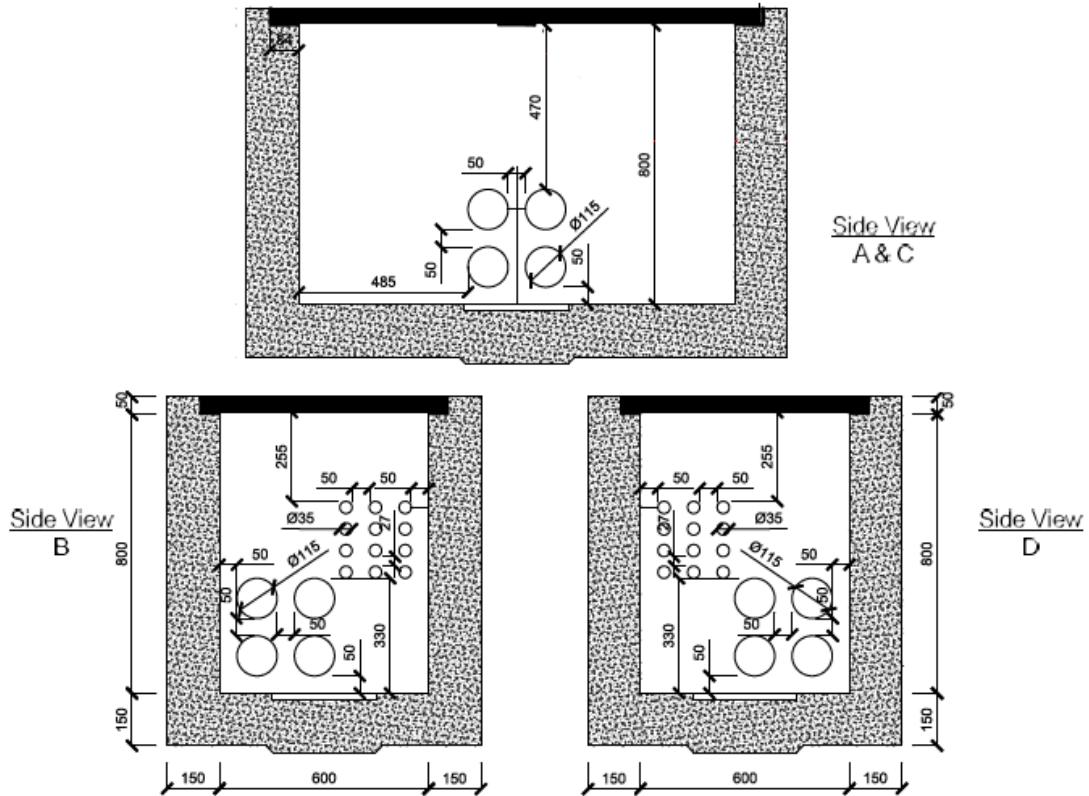

Note: this graph is for duct entrance configuration only, for complete dimension reading please refer to appendix 2 –B.

Category : Civil Item
Spec. No. : VM 103
Date : 6-7-2020
Issue :5

Hand-holes with Covers



2-B: Handhole Type 2, Two Covers (FTTH Type)

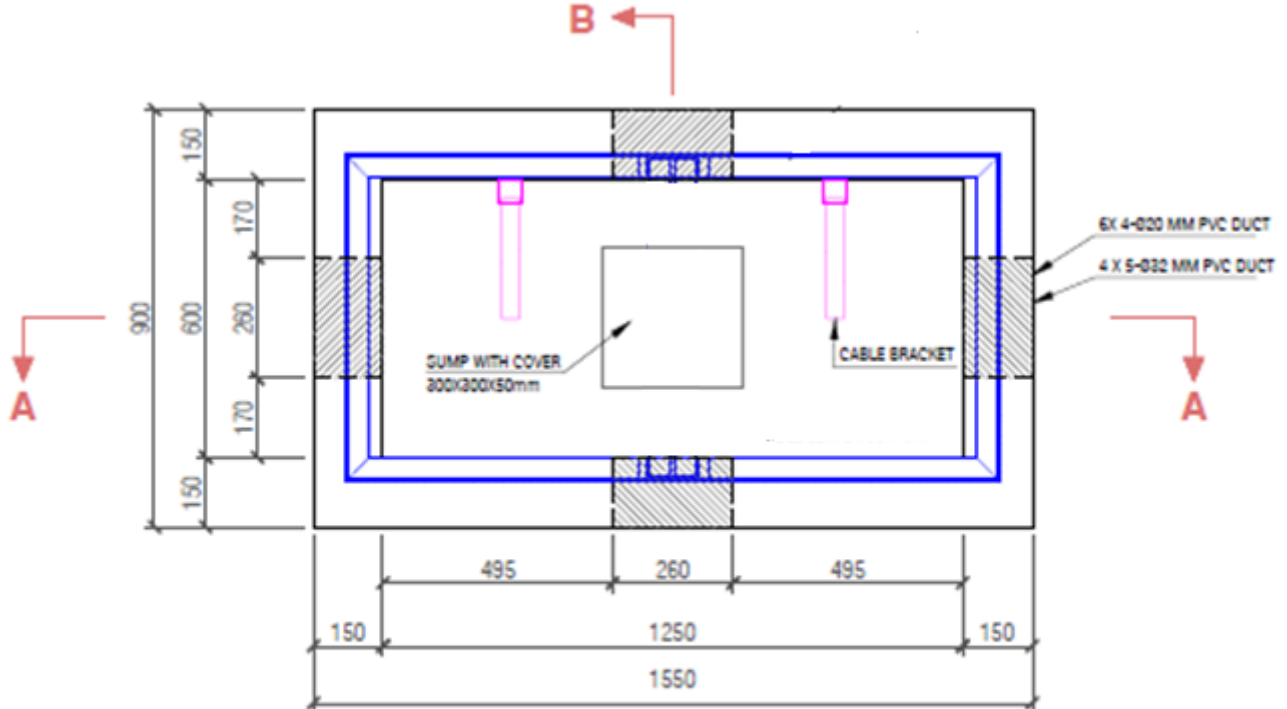

PLAN

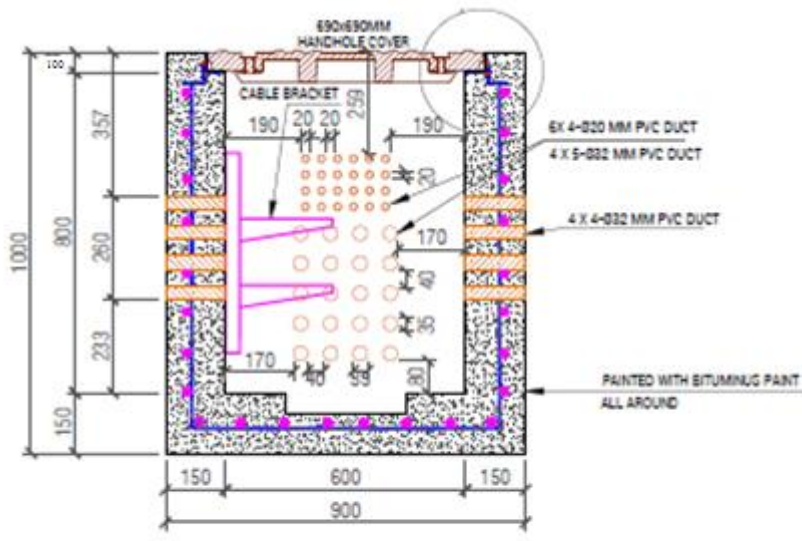

SECTION B-B

Category : Civil Item
Spec. No. : VM 103
Date : 6-7-2020
Issue :5

Hand-holes with Covers

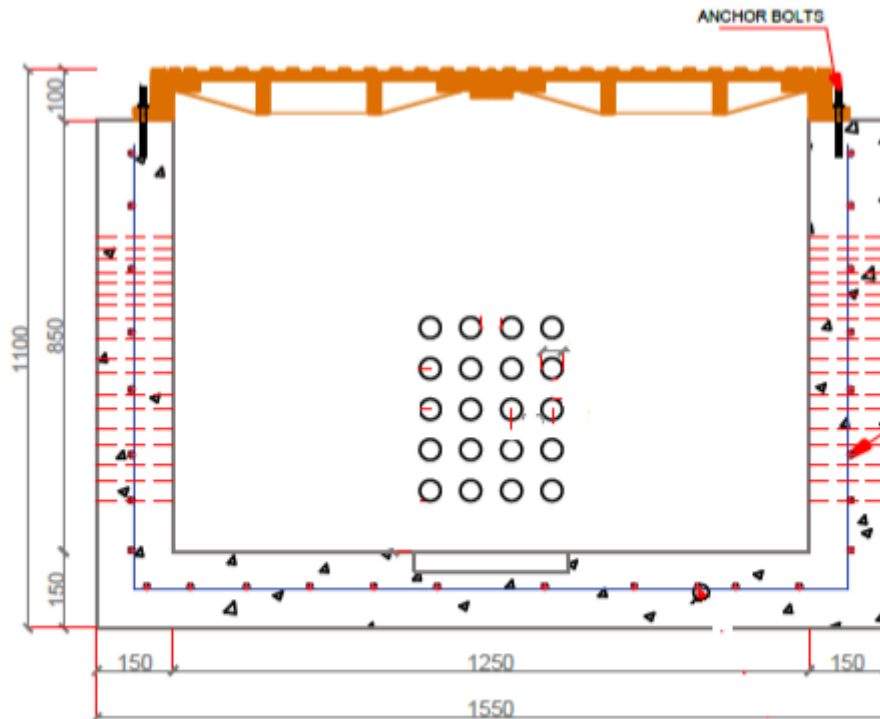

Frame cover depth and position

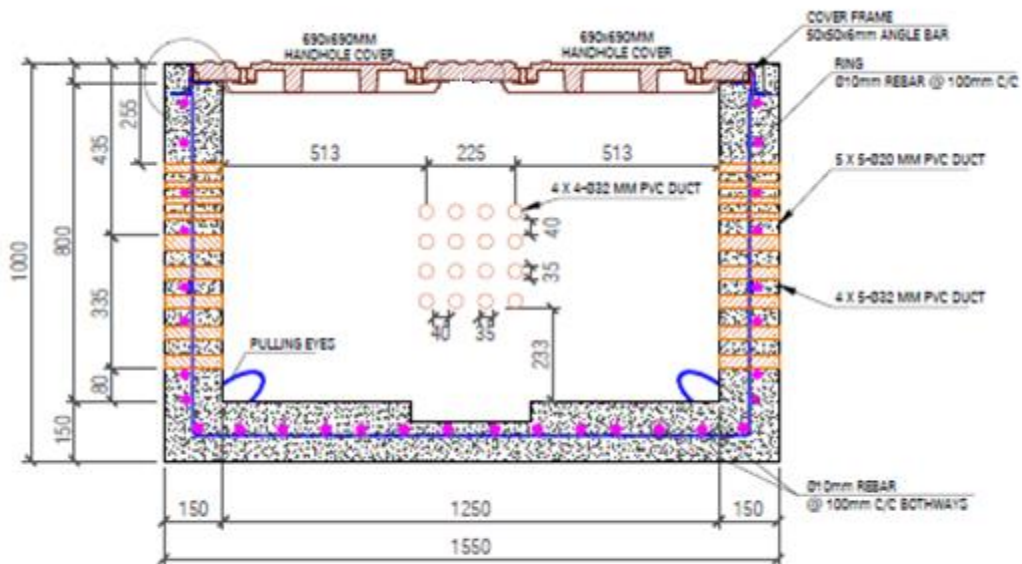

SECTION A-A

Category : Civil Item
Spec. No. : VM 103
Date : 6-7-2020
Issue :5

Hand-holes with Covers

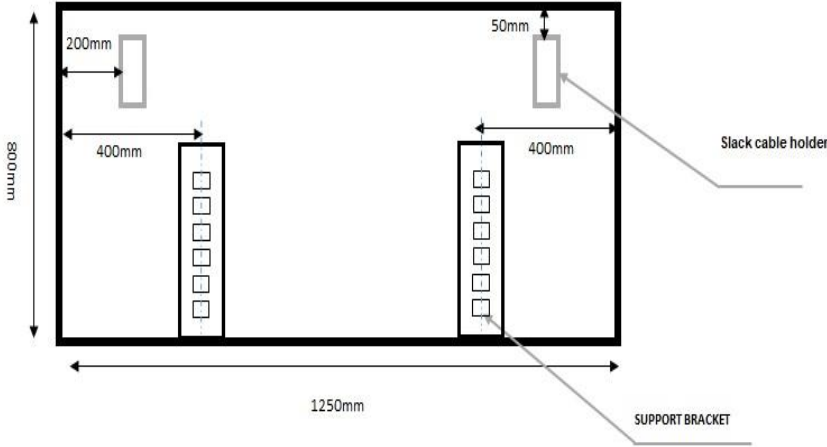

Section A-C
Slack Cable Holder & Bracket Support position

Category : Civil Item Spec. No. : VM 103 Date : 6-7-2020 Issue :5	<u>Hand-holes with Covers</u>	
--	-------------------------------	---

2-C: Handhold Type 2, Two Cover (FTTH Type Window)

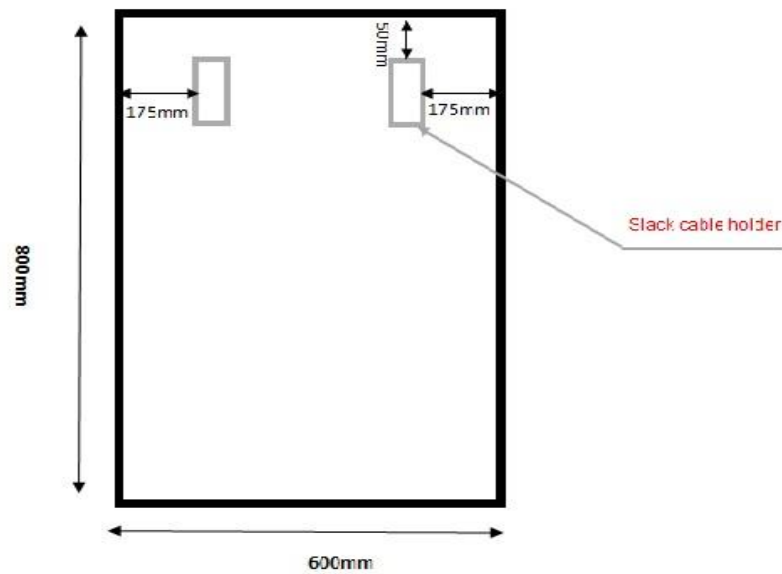
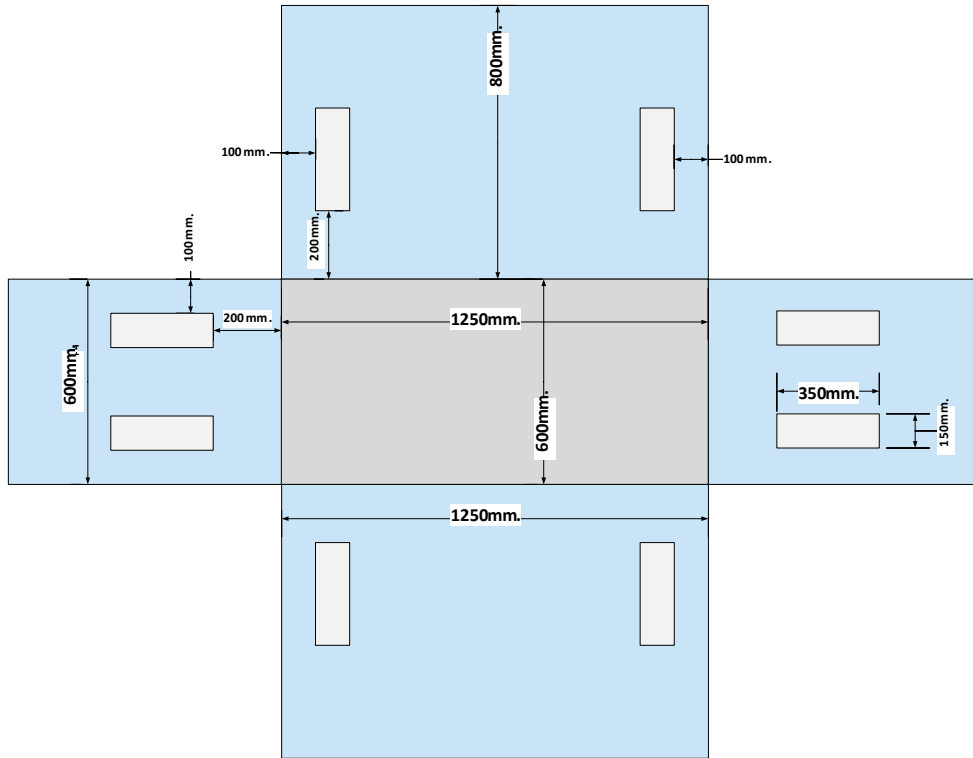

**Section D-B
Slack Cable Holder position**

Category : Civil Item
 Spec. No. : VM 103
 Date : 6-7-2020
 Issue :5

Hand-holes with Covers



Appendix 3: Handhole 2 covers with hinges Details

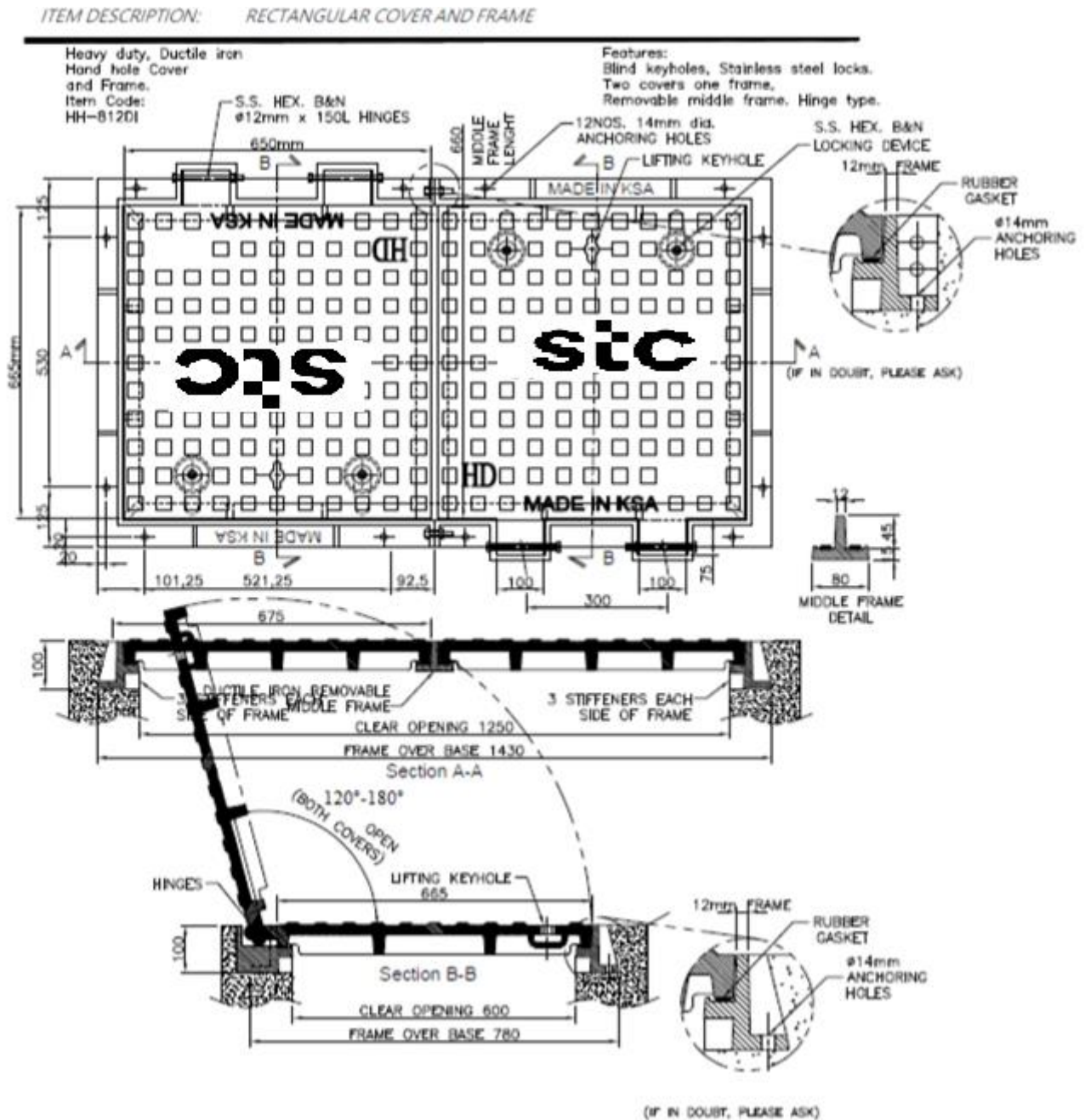

Category : Civil Item Spec. No. : VM 103 Date : 6-7-2020 Issue :5	<u>Hand-holes with Covers</u>	
--	-------------------------------	---

Appendix 4: Marking Plate and QR Code :



The inserted information in clause 3.3 has to be printed clearly in the plate and appear when the QR code scanning.
 For more details please see “VP 106 Technical Specifications “.

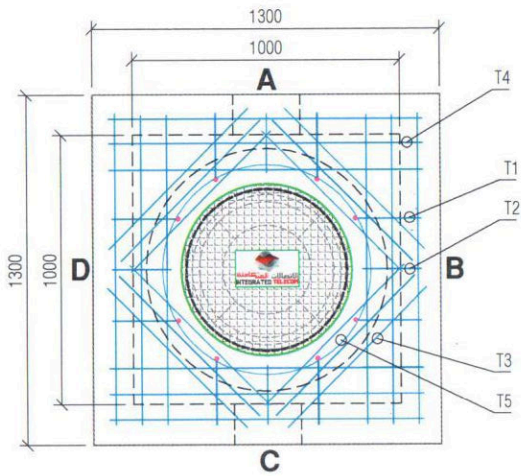

TOP SLAB REINFORCEMENT

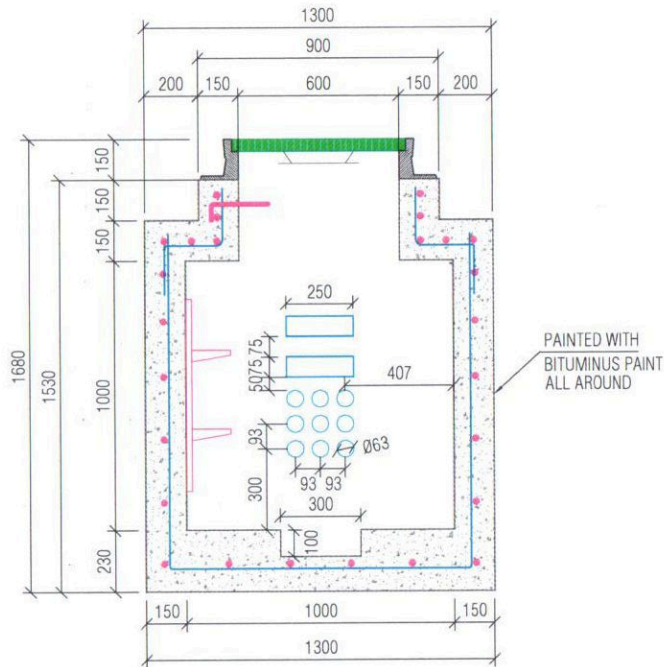

SECTION B-D

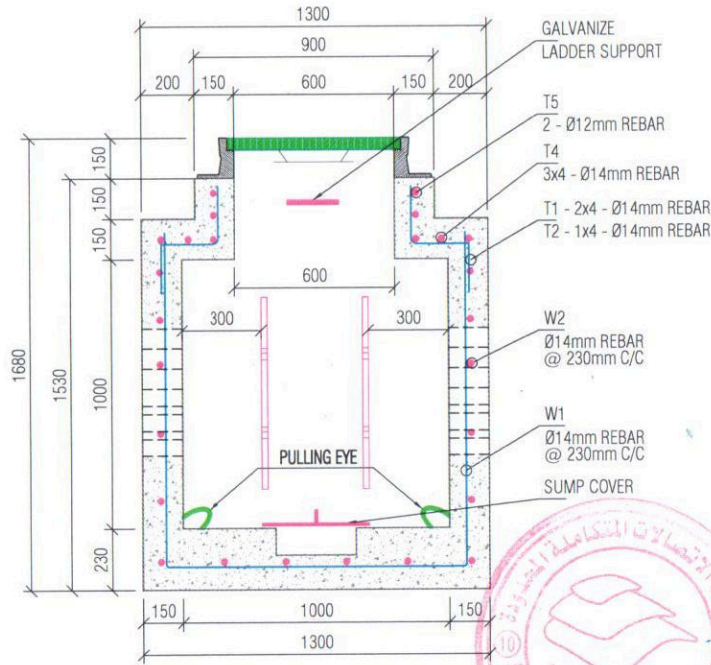

SECTION A-C

REINFORCEMENT SCHEDULE

a	1150	200	200	250	750	1175	2355
b	1150	1150	220	200		80	150
c			175				
	W1	T4	T1	T2	T3	W2	T5
	Ø14mm @ 230mm C/C	3 x 4 Ø14mm	2 x 4 Ø14mm	1 x 4 Ø14mm	3 x 4 Ø14mm	Ø14mm @ 230mm C/C	2-Ø12mm
	12 NOs	12 NOs	8 NOs	4 NOs	12 NOs	5 NOs	2 NOs
	RABAR = 124.21 kg				CONCRETE = 1.23cu.m.		

NOTES:

1. ALL DIMENSIONS ARE IN MILLIMETERS UNLESS OTHERWISE SPECIFIED.
2. CONCRETE COMPRESSIVE STRENGTH SHALL BE MINIMUM OF 4000 PSI AT 28 DAYS.
3. CEMENT SHALL BE SULFATE RESISTANT, TYPE V CONFORMING TO ASTM C150.
4. WALLS EXPOSE TO EARTH SHALL BE COATED WITH APPROVED BITUMINOUS MATERIAL.
5. REINFORCEMENT BARS SHALL CONFORM TO ASTM A615, GRADE 60.
6. PROVIDE 45 TON HEAVY DUTY CAST IRON COVER.

MANHOLE ACCESSORIES	UNIT	QUANTITY
SUMP COVER	EACH	1
CABLE BRACKET	EACH	4
CABLE BRACKET SUPPORT	EACH	2
EXPANSION BOLTS	EACH	4
LADDER SUPPORT	EACH	1
PULLING EYE	EACH	2
MARKING PLATE	EACH	1
MANHOLE COVER-HEAVY DUTY	EACH	1
MANHOLE COVER FRAME	EACH	1
LADDER	EACH	1

MANUFACTURER:



DORAT ALTAL
ESTABLISHMENT
TEL. No : 01 - 466 0408/ 810 7614
FAX. No : 01 - 466 1016
EMAIL: dorat@doratal.com/ ayad@doratal.com

ENGR:	ENGR1	SCALE:	SCALE
CAD:	CAD1	HOR.	
REV.	DATE	VERT.	
		DRAWING NO.	
		SHEET NO.	1 OF 1
		DATE:	
		CHECKED BY:	
		APPROVED BY:	
		SIGN:	

MINI-MANHOLE TYPE-1



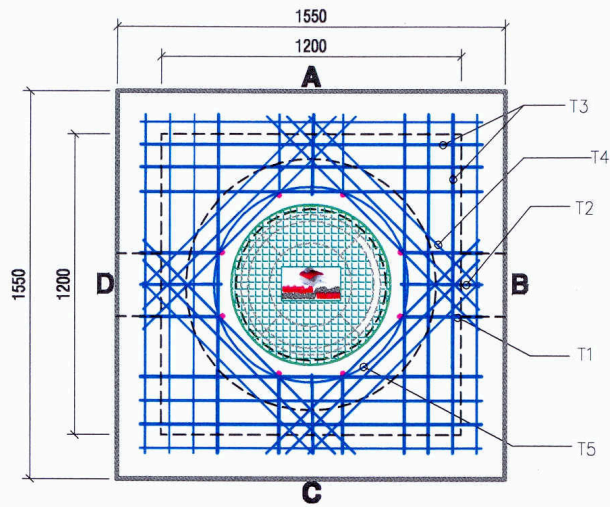

TOP SLAB REINFORCEMENT

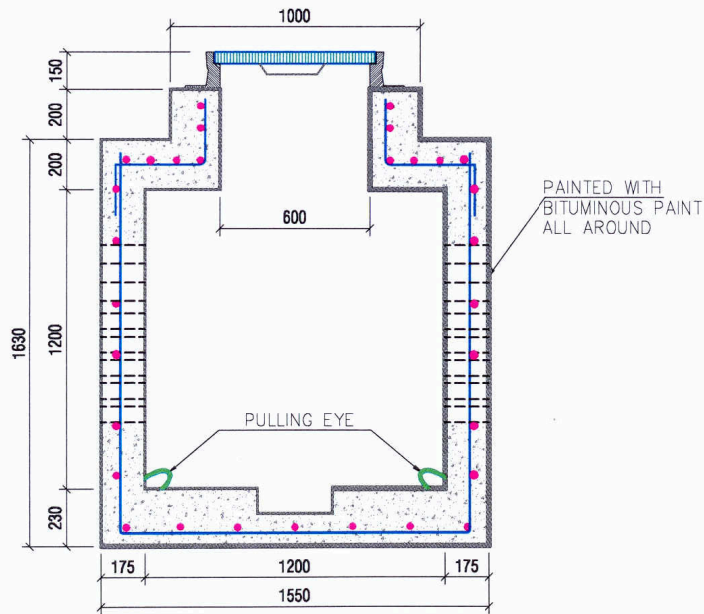

SECTION B-D

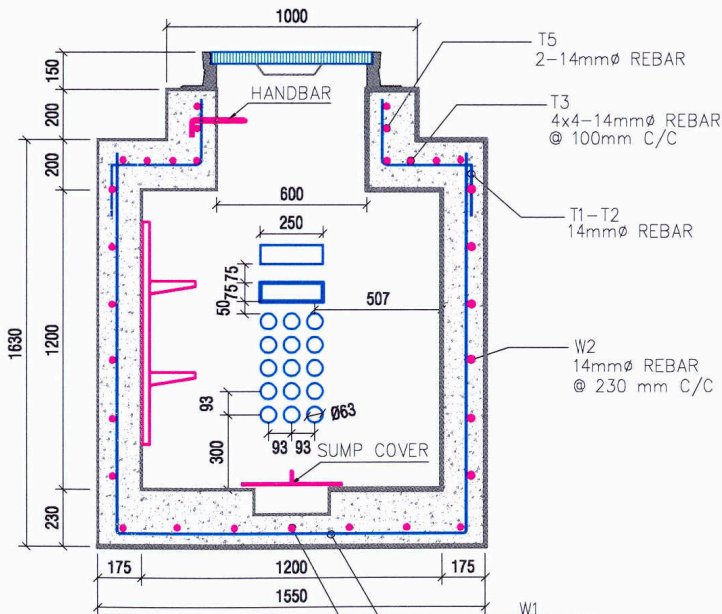

SECTION A-C

REINFORCEMENT SCHEDULE

a	1480	200	430	1100	250	1400
b	1375	1375	200		330	80
c					200	
W1	T3	T2	T4	T1	W2	T5
14mm ϕ @230mm C/C	4x4 18mm ϕ	1x4 14mm ϕ	3x4 14mm ϕ	4x2 14mm ϕ	14mm ϕ @200mm C/C	2-14mm ϕ
14 NOs	16 NOs	4 NOs	12 NOs	8 NOs	6 NOs	2 NOs
REBAR = 182.35 kg				CONCRETE = 2.13 cu.m.		

NOTES:

1. ALL DIMENSIONS ARE IN MILLIMETERS UNLESS OTHERWISE SPECIFIED.
2. CONCRETE COMPRESSIVE STRENGTH SHALL BE MINIMUM OF 4000 PSI AT 28 DAYS.
3. CEMENT SHALL BE SULFATE RESISTANT, TYPE V CONFORMING TO ASTM C150.
4. WALLS EXPOSE TO EARTH SHALL BE COATED WITH APPROVED BITUMINOUS MATERIAL.
5. REINFORCEMENT BARS SHALL CONFORM TO ASTM A615, GRADE 60.
6. PROVIDE 45 TON HEAVY DUTY CAST IRON COVER.

MANHOLE ACCESSORIES	UNIT	QUANTITY
SUMP COVER	EACH	1
CABLE BRACKET	EACH	4
CABLE BRACKET SUPPORT	EACH	2
EXPANSION BOLTS	EACH	4
HANDBAR	EACH	1
MANHOLE LADDER	EACH	1
PULLING EYE	EACH	2
MARKING PLATE	EACH	1
MANHOLE COVER - HEAVY DUTY	EACH	1
MANHOLE COVER FRAME	EACH	1



CONTRACTOR:

		SCALE:	SCALE
ENGR.:	DWR1	HDR.:	
CAD.:	CAD1	VERT.:	
REV.	DATE	SIGN	DRAWING NO.
			SHEET NO. 1 OF 1
ITC MINI-MANHOLE		DATE:	
MINI-MANHOLE TYPE-2		CHECKED BY:	
		APPROVED BY:	
		SIGN:	

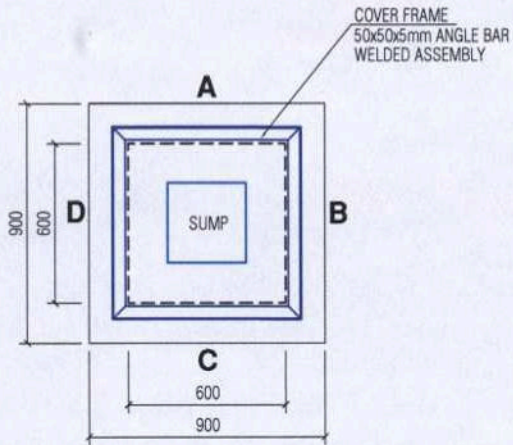

PLAN

REINFORCEMENT SCHEDULE			
a	850	775	
b	750	80	
c			
	W1	W2	
	12mmØ @145mm C/C	10mmØ	
	12 NOs	8 NOs	
	REBAR = 42.17g	CONCRETE = 0.504 cu.m.	

NOTES:

1. ALL DIMENSIONS ARE IN MILLIMETERS UNLESS OTHER WISE SPECIFIED.
2. CONCRETE COMPRESSIVE STRENGTH SHALL BE MINIMUM OF 4000 PSI AT 28 DAYS.
3. CEMENT SHALL BE SULFATE RESISTANT, TYPE V CONFORMING TO ASTM C150.
4. WALLS EXPOSE TO EARTH SHALL BE COATED WITH APPROVED BITUMINOUS MATERIAL.
5. REINFORCEMENT BARS SHALL CONFORM TO ASTM A615, GRADE 60.
6. PROVIDE 15 TONS MEDIUM DUTY CAST IRON COVER.

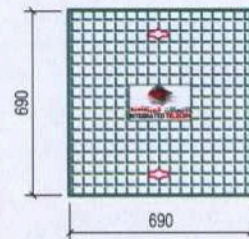

HANDHOLE COVER

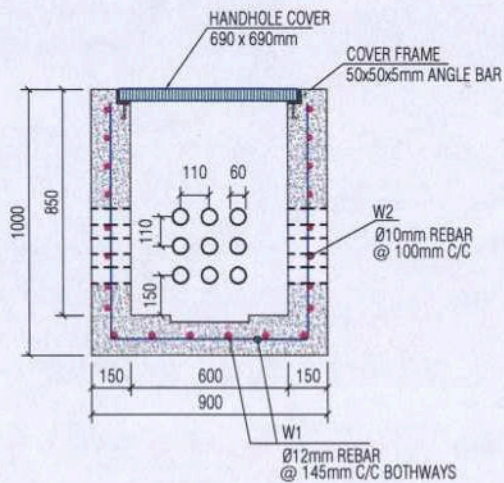

SECTION A-C

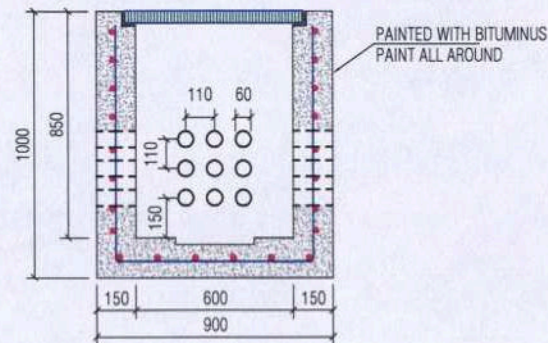

SECTION B-D

HANDHOLE ACCESSORIES	UNIT	QUANTITY
HANDHOLE COVER-MEDIUM DUTY	EACH	1
HANDHOLE COVER FRAME	EACH	1



ENGR.	DWRH
CAD.	GAD1
REV.	DATE
	SIGN

SCALE:	SCALE
HOR.	
VERT.	
DRAWING NO.	
SHEET NO.	1 OF 1
DATE:	
CHECKED BY:	
APPROVED BY:	
SIGN:	

**ONE COVER
HANDHOLE DESIGN**

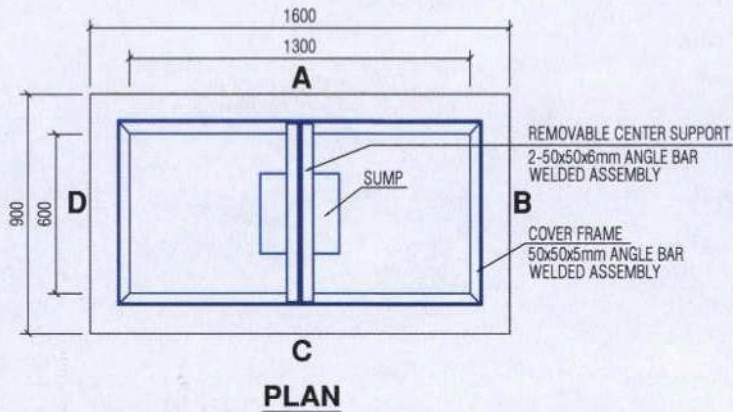

REINFORCEMENT SCHEDULE

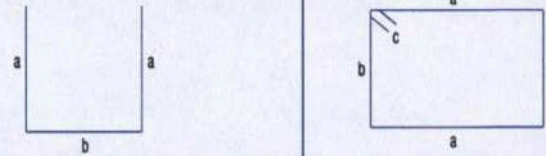

a	850	850	1475
b	1450	750	775
c			80
W1			
	12mmØ @140mm C/C	12mmØ @140mm C/C	10mmØ
	7 NOs	11 NOs	8 NOs
REBAR = 61.52 kg		CONCRETE = 0.777 cu.m.	

NOTES:

1. ALL DIMENSIONS ARE IN MILLIMETERS UNLESS OTHER WISE SPECIFIED.
2. CONCRETE COMPRESSIVE STRENGTH SHALL BE MINIMUM OF 4000 PSI AT 28 DAYS.
3. CEMENT SHALL BE SULFATE RESISTANT, TYPE V CONFORMING TO ASTM C150.
4. WALLS EXPOSE TO EARTH SHALL BE COATED WITH APPROVED BITUMINOUS MATERIAL.
5. REINFORCEMENT BARS SHALL CONFORM TO ASTM A615, GRADE 60.
6. PROVIDE 15 TONS MEDIUM DUTY CAST IRON COVER.

HANDHOLE ACCESSORIES	UNIT	QUANTITY
HANDHOLE COVER-MEDIUM DUTY	EACH	1
HANDHOLE COVER FRAME	EACH	1
CABLE BRACKET	EACH	4
CABLE BRACKET SUPPORT	EACH	2
EXPANSION BOLTS & NUTS	EACH	4

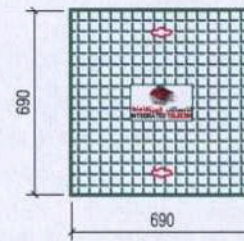

HANDHOLE COVER

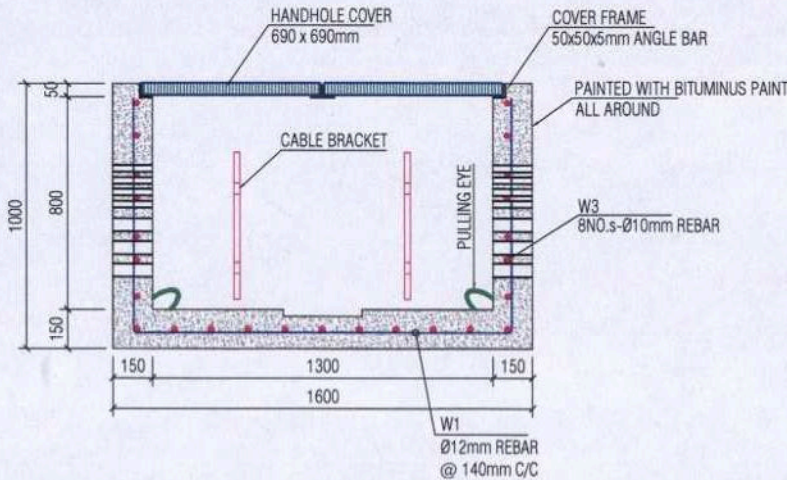

SECTION B-D

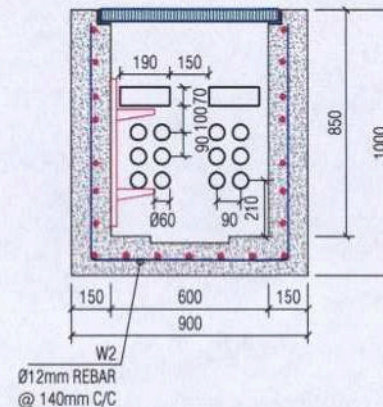

SIDE A & C



ENGR.	CHRY	SCALE:	SCALE
CAD:	GADI	CHK:	
REV.	DATE	VERT.	
		DRAWING NO.	
		SHEET NO.	1 OF 1
		DATE:	
		CHECKED BY:	
		APPROVED BY:	
		SIGN:	

TWO COVER HANDHOLE DESIGN

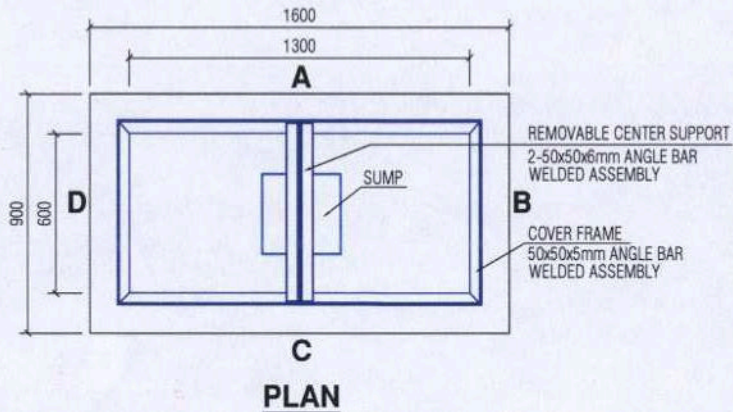

REINFORCEMENT SCHEDULE

a	850	850	1475
b	1450	750	775
c			80
W1	12mmØ @140mm C/C	12mmØ @140mm C/C	10mmØ
	7 NOs	11 NOs	8 NOs
REBAR = 61.52 kg		CONCRETE = 0.777 cu.m.	

NOTES:

1. ALL DIMENSIONS ARE IN MILLIMETERS UNLESS OTHERWISE SPECIFIED.
2. CONCRETE COMPRESSIVE STRENGTH SHALL BE MINIMUM OF 4000 PSI AT 28 DAYS.
3. CEMENT SHALL BE SULFATE RESISTANT, TYPE V CONFORMING TO ASTM C150.
4. WALLS EXPOSE TO EARTH SHALL BE COATED WITH APPROVED BITUMINOUS MATERIAL.
5. REINFORCEMENT BARS SHALL CONFORM TO ASTM A615, GRADE 60.
6. PROVIDE 15 TONS MEDIUM DUTY CAST IRON COVER.

HANDHOLE ACCESSORIES	UNIT	QUANTITY
HANDHOLE COVER-MEDIUM DUTY	EACH	1
HANDHOLE COVER FRAME	EACH	1
CABLE BRACKET	EACH	4
CABLE BRACKET SUPPORT	EACH	2
EXPANSION BOLTS & NUTS	EACH	4

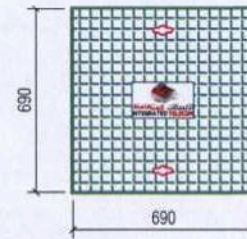

HANDHOLE COVER

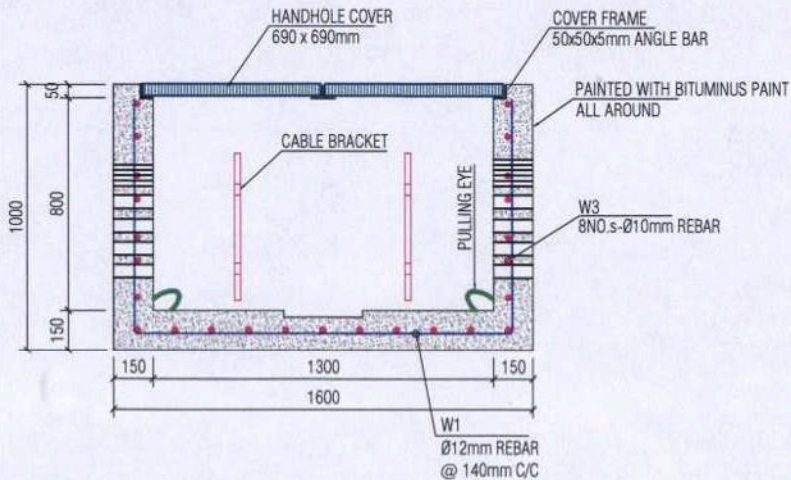

SECTION B-D

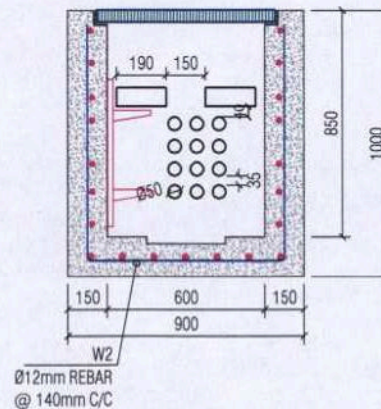

SIDE A & C



ENGR:	IMDR	SCALE:	SCALE
CAD:	CADR	HDR:	
REV.	DATE	VERT.	
		DRAWING NO.	
		SHEET NO.	1 OF 1
		DATE:	
		CHECKED BY:	
		APPROVED BY:	
		SIGN:	

TWO COVER HANDHOLE DESIGN

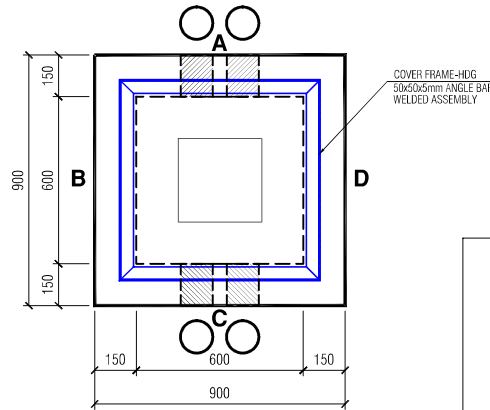

PLAN

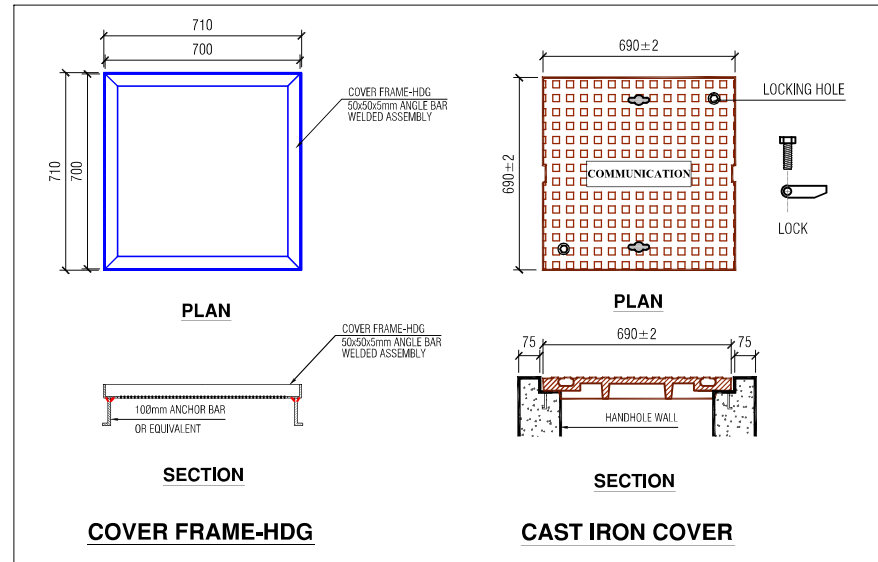

COVER FRAME-HDG

CAST IRON COVER

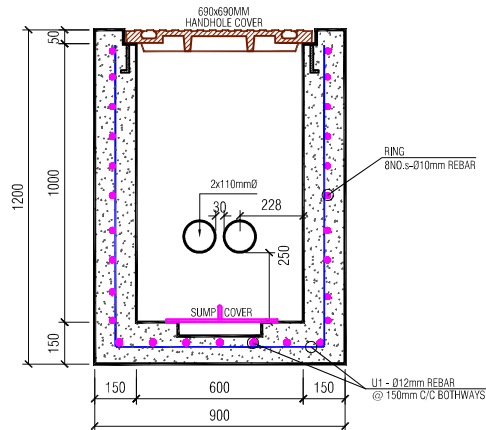

SECTION B-D

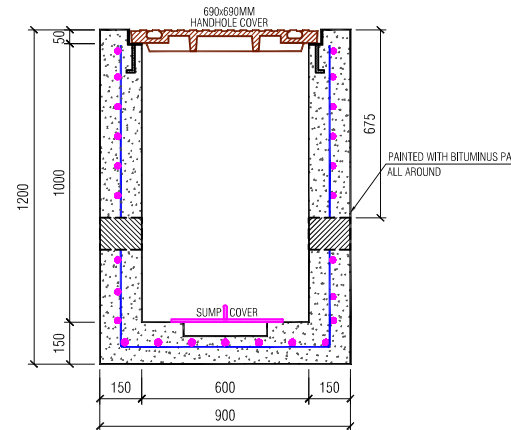

SECTION A-C

REINFORCEMENT SCHEDULE	RING	
	U1	RING
a	1100	775
b	750	100
	12Ø@150mm	10Ø@150mm
	5Pcs	7Pcs
REBAR WT. = 26 Kg.		CONCRETE VOL. = 0.594Cu.M.

NO.	ACCESSORIES CHECKLIST	QUANTITY
1	HANDHOLE COVER-HD(690mmx690mm)	1 EA
2	HANDHOLE FRAME (50mmx50mmx5)	1 EA
3	SUMP COVER(400mmx400mm)	1 EA
4	MARKING PLATE	1 EA

- NOTES:**
- ALL DIMENSIONS ARE IN MILLIMETERS UNLESS OTHERWISE INDICATED.
 - CONCRETE CYLINDER COMPRESSIVE STRENGTH SHALL BE MINIMUM OF 4000 PSI AT 28 DAYS.
 - CEMENT SHALL BE SULFATE RESISTANT, TYPE V CONFORMING TO ASTM C150.
 - STEEL REINFORCEMENTS SHALL CONFORM TO ASTM A615, DEFORMED BARS GRADE 60 WITH MINIMUM YIELD STRENGTH OF 420MPa.
 - EXTERNAL SUFACES SHALL BE COATED WITH 2-LAYERS OF BITUMINOUS.
 - PRE-FORMED STRUCTURE COVER SHALL BE HEAVY DUTY(H-40).
 - HOT DIP GALVANIZED STEEL ACCESSORIES.



Ministry of Interior
Kingdom of Saudi Arabia

MANUFACTURER:

ENGR.:	ENGR1	PROJECT:	MIFON II	SCALE:	SCALE
CAD:	CAD1			HOR:	
REV. #1	DATE: 19/06/16	SIGN:		VERT:	
			TITLE:	DRAWING NO.	
			HANDHOLE ONE COVER FOR MOI (PULLING BOX)	SHEET NO.	1 OF 1
			LENGTH x WIDTH x HEADROOM	DATE:	
			OD : 900 X 900 X 1200	CHECKED BY:	
			ID : 600 X 600 X 1000	APPROVED BY:	
				SIGN:	

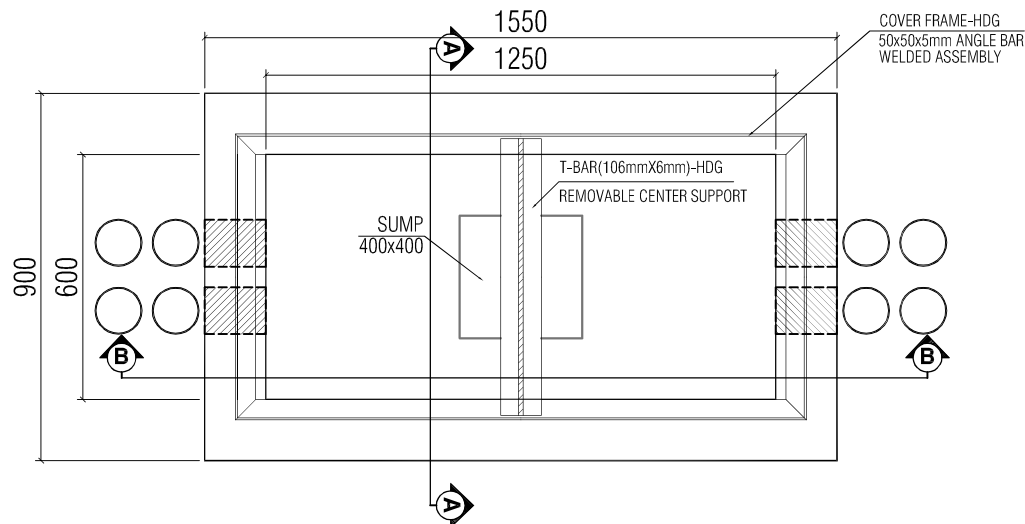

PLAN

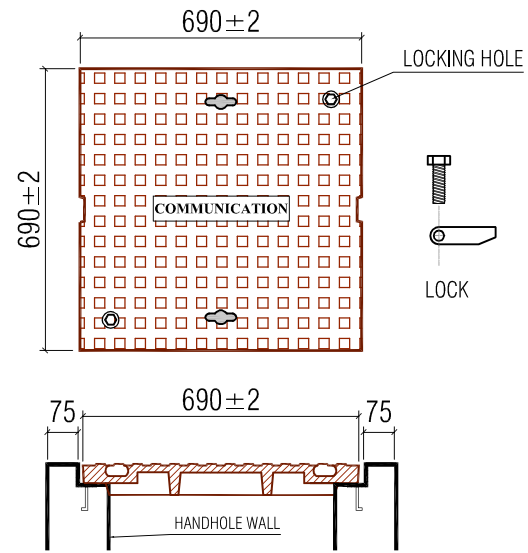
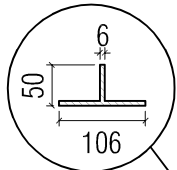

CAST IRON COVER

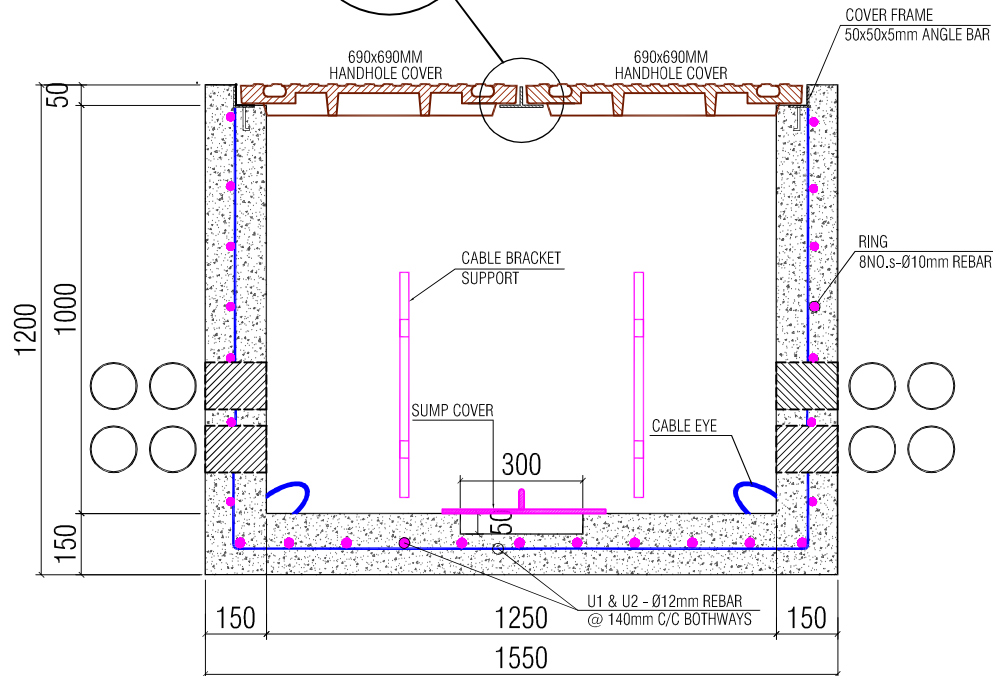

SECTION B

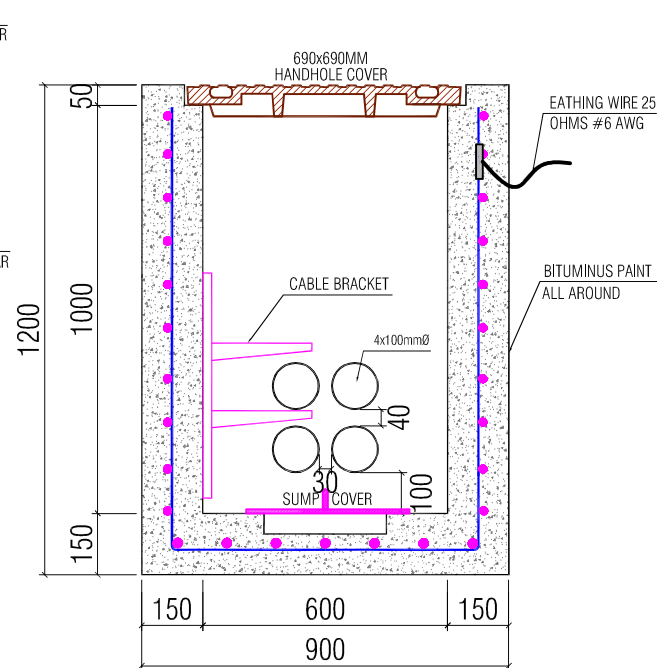

SECTION A

NO.	ACCESSORIES CHECKLIST	QUANTITY
1	SUMP COVER(400mmx400mm)	1 EA
2	CABLE BRACKET SUPPORT(500mm)	2 EA
3	CABLE BRACKET(250mm)	4 EA
4	HANDHOLE COVER-HD(690mmx690mm)	2 EA
5	HANDHOLE FRAME (50mmx50mmx5)	1 EA
6	T-BAR(106MM WIDTH)	1 EA
7	COMPLETE GROUNDING SYSTEM	1 EA
8	PULLING EYE	2 EA
9	MARKING PLATE	1 EA
10	EXPANSION BOLT	4 EA
11	LIFTING BAR	4 EA

NOTES:

- ALL DIMENSIONS ARE IN MILLIMETERS UNLESS OTHERWISE INDICATED.
- CONCRETE CYLINDER COMPRESSIVE STRENGTH SHALL BE MINIMUM OF 4000 PSI AT 28 DAYS.
- CEMENT SHALL BE SULFATE RESISTANT, TYPE V CONFORMING TO ASTM C150.
- STEEL REINFORCEMENTS SHALL CONFORM TO ASTM A615, DEFORMED BARS GRADE 60 WITH MINIMUM YIELD STRENGTH OF 420MPa.
- EXTERNAL SURFACES SHALL BE COATED WITH 2-LAYERS OF BITUMINOUS.
- PRE-FORMED STRUCTURE COVER SHALL BE HEAVY DUTY(H-40).
- HOT DIP GALVANIZED STEEL ACCESSORIES.



Ministry of Interior
Kingdom of Saudi Arabia

MANUFACTURER:

DORAT AL TAL Factory

Tel. No. : 011 466 0408
doratal@dorataltal.com

ENGR:	PROJECT:	SCALE:
CAD:		SCALE
CAD1		HOR.
		VERT.
REV. #1	DATE: 03/08/15	DRAWING NO.:
		SHEET NO. 1 OF 1
		DATE:
		CHECKED BY:
		APPROVED BY:
		SIGN:

HANDHOLE TWO COVER FOR MOI
(OPTION-2)

LENGTH x WIDTH x HEADROOM
OD : 1550 X 900 X 1200
ID : 1250 X 600 X 1000

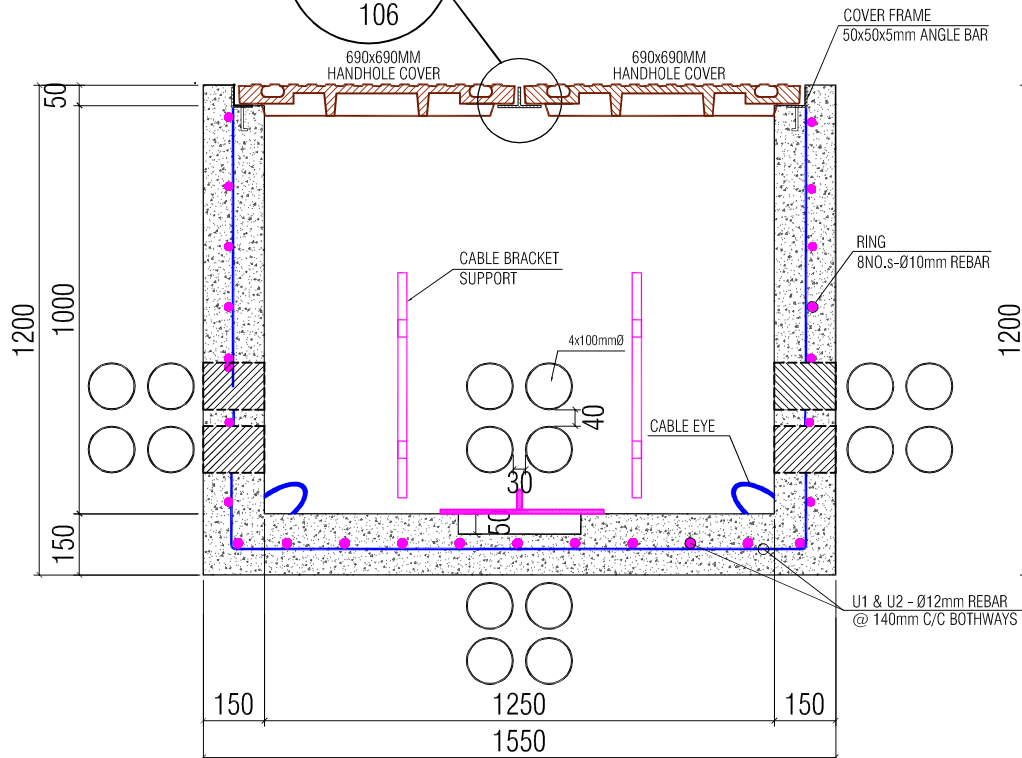
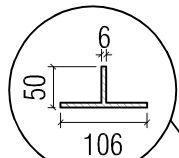
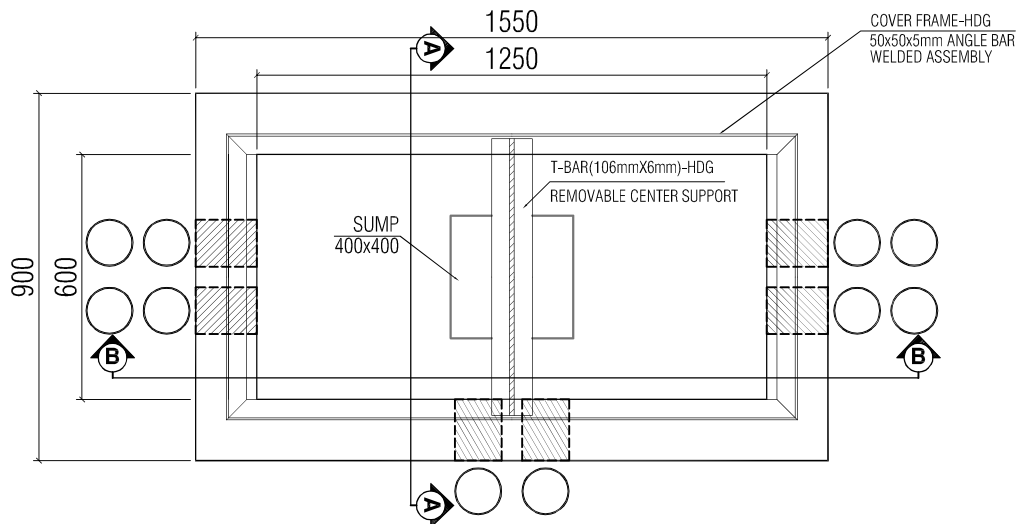

SECTION B

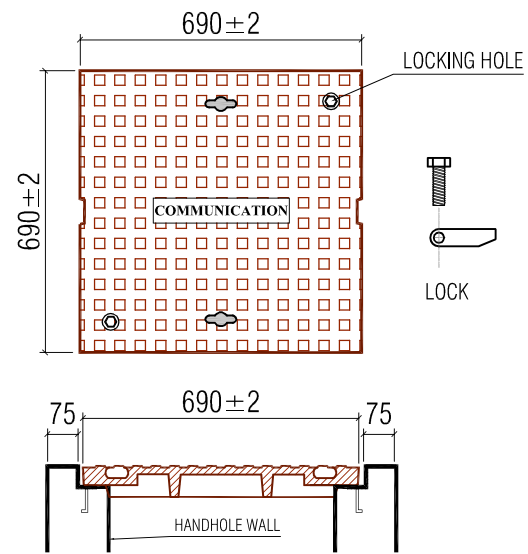

CAST IRON COVER

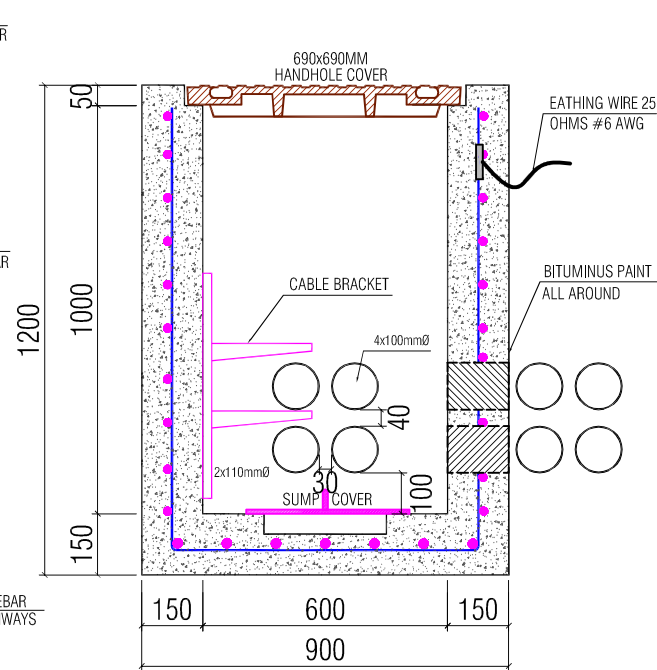

SECTION A

NO.	ACCESSORIES CHECKLIST	QUANTITY
1	SUMP COVER(400mmx400mm)	1 EA
2	CABLE BRACKET SUPPORT(500mm)	2 EA
3	CABLE BRACKET(250mm)	4 EA
4	HANDHOLE COVER-HD(690mmx690mm)	2 EA
5	HANDHOLE FRAME (50mmx50mmx5)	1 EA
6	T-BAR(106MM WIDTH)	1 EA
7	COMPLETE GROUNDING SYSTEM	1 EA
8	PULLING EYE	2 EA
9	MARKING PLATE	1 EA
10	EXPANSION BOLT	4 EA
11	LIFTING BAR	4 EA

NOTES:

- ALL DIMENSIONS ARE IN MILLIMETERS UNLESS OTHERWISE INDICATED.
- CONCRETE CYLINDER COMPRESSIVE STRENGTH SHALL BE MINIMUM OF 4000 PSI AT 28 DAYS.
- CEMENT SHALL BE SULFATE RESISTANT, TYPE V CONFORMING TO ASTM C150.
- STEEL REINFORCEMENTS SHALL CONFORM TO ASTM A615, DEFORMED BARS GRADE 60 WITH MINIMUM YIELD STRENGTH OF 420MPa.
- EXTERNAL SURFACES SHALL BE COATED WITH 2-LAYERS OF BITUMINOUS.
- PRE-FORMED STRUCTURE COVER SHALL BE HEAVY DUTY(H-40).
- HOT DIP GALVANIZED STEEL ACCESSORIES.



Ministry of Interior
Kingdom of Saudi Arabia

MANUFACTURER:

DORAT AL TAL Factory

Tel. No.: 011 466 0408
doratal@doratal.com

ENGR:	PROJECT:	SCALE:
CAD:		SCALE
		HOR.
		VERT.
REV. #1	DATE: 03/08/15	DRAWING NO.:
		SHEET NO. 1 OF 1
		DATE:
		CHECKED BY:
		APPROVED BY:
		SIGN:

HANDHOLE TWO COVER FOR MOI
(OPTION-2)

LENGTH x WIDTH x HEADROOM
OD : 1550 X 900 X 1200
ID : 1250 X 600 X 1000

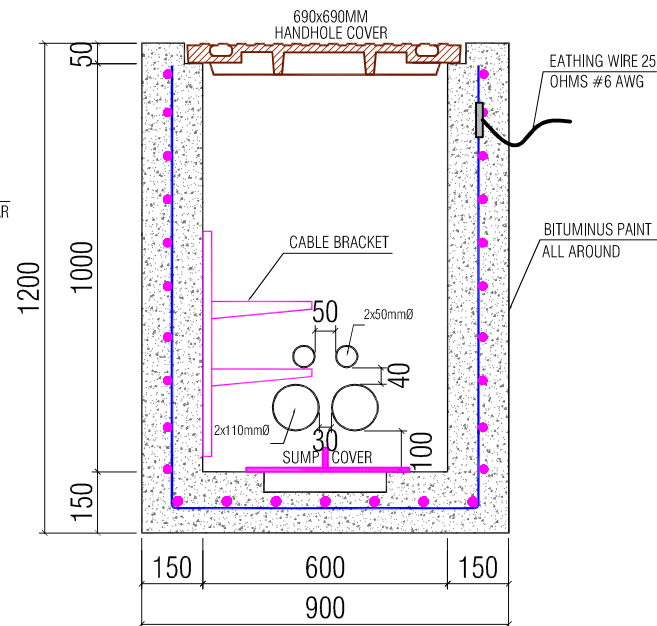
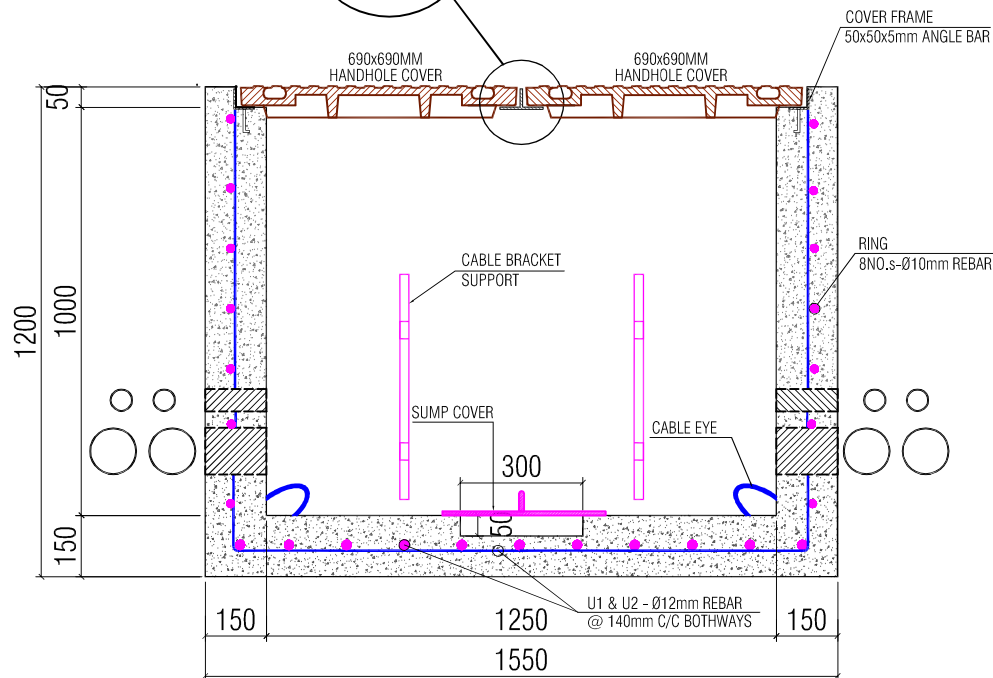
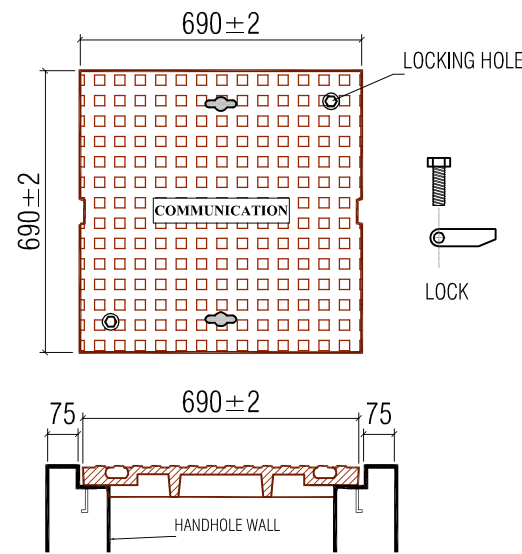
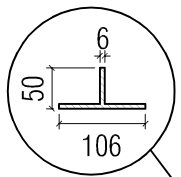
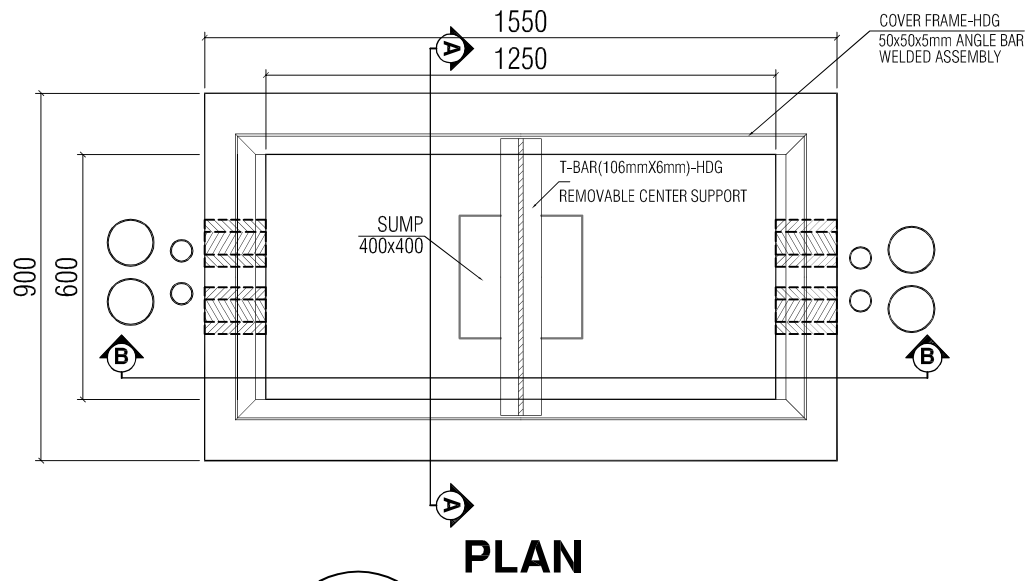

NO.	ACCESSORIES CHECKLIST	QUANTITY
1	SUMP COVER(400mmx400mm)	1 EA
2	CABLE BRACKET SUPPORT(500mm)	2 EA
3	CABLE BRACKET(250mm)	4 EA
4	HANDHOLE COVER-HD(690mmx690mm)	2 EA
5	HANDHOLE FRAME (50mmx50mmx5)	1 EA
6	T-BAR(106MM WIDTH)	1 EA
7	COMPLETE GROUNDING SYSTEM	1 EA
8	PULLING EYE	2 EA
9	MARKING PLATE	1 EA
10	EXPANSION BOLT	4 EA
11	LIFTING BAR	4 EA

NOTES:

- ALL DIMENSIONS ARE IN MILLIMETERS UNLESS OTHERWISE INDICATED.
- CONCRETE CYLINDER COMPRESSIVE STRENGTH SHALL BE MINIMUM OF 4000 PSI AT 28 DAYS.
- CEMENT SHALL BE SULFATE RESISTANT, TYPE V CONFORMING TO ASTM C150.
- STEEL REINFORCEMENTS SHALL CONFORM TO ASTM A615, DEFORMED BARS GRADE 60 WITH MINIMUM YIELD STRENGTH OF 420MPa.
- EXTERNAL SURFACES SHALL BE COATED WITH 2-LAYERS OF BITUMINOUS.
- PRE-FORMED STRUCTURE COVER SHALL BE HEAVY DUTY(H-40).
- HOT DIP GALVANIZED STEEL ACCESSORIES.



Ministry of Interior
Kingdom of Saudi Arabia

MANUFACTURER:

DORAT AL TAL Factory

Tel. No.: 011 466 0408
doratal@dorataltal.com

ENGR:	PROJECT:	SCALE:
CAD:		SCALE
CAD1		VERT.
REV. #1	DATE: 03/08/15	SIGN:
	HANDHOLE TWO COVER FOR MOI (OPTION-2)	DRAWING NO.
		SHEET NO. 1 OF 1
	LENGTH x WIDTH x HEADROOM	DATE:
	OD : 1550 X 900 X 1200	CHECKED BY:
	ID : 1250 X 600 X 1000	APPROVED BY:
		SIGN:

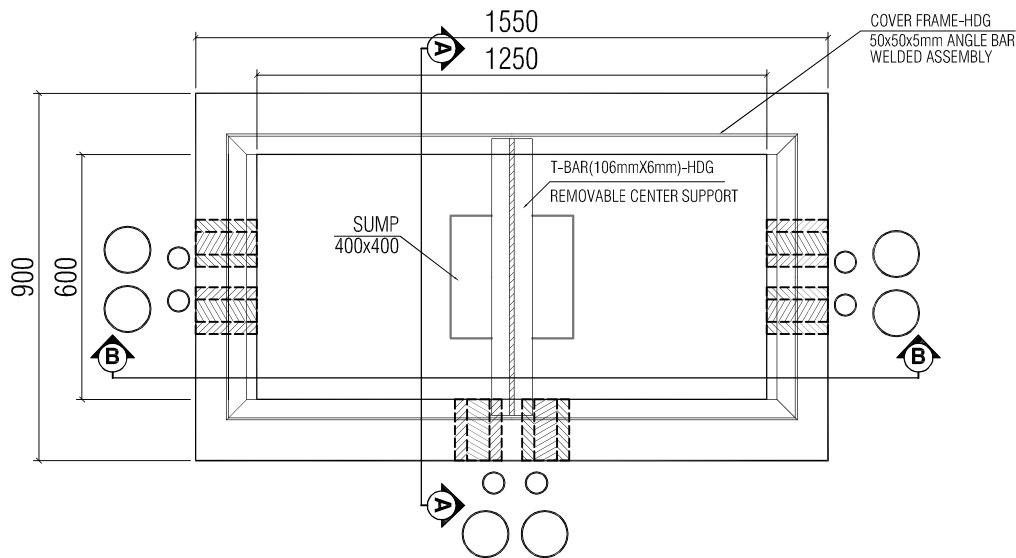

PLAN

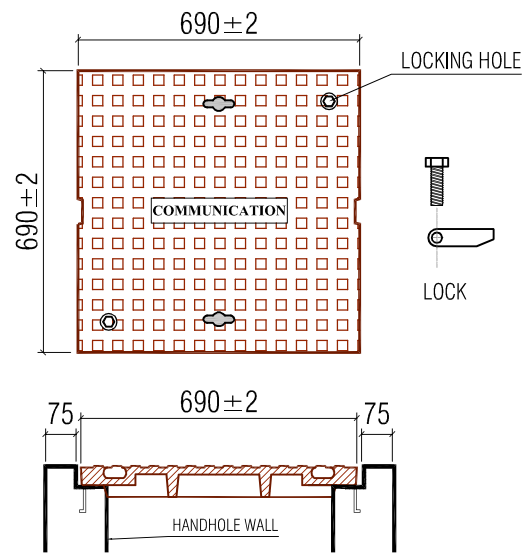

CAST IRON COVER

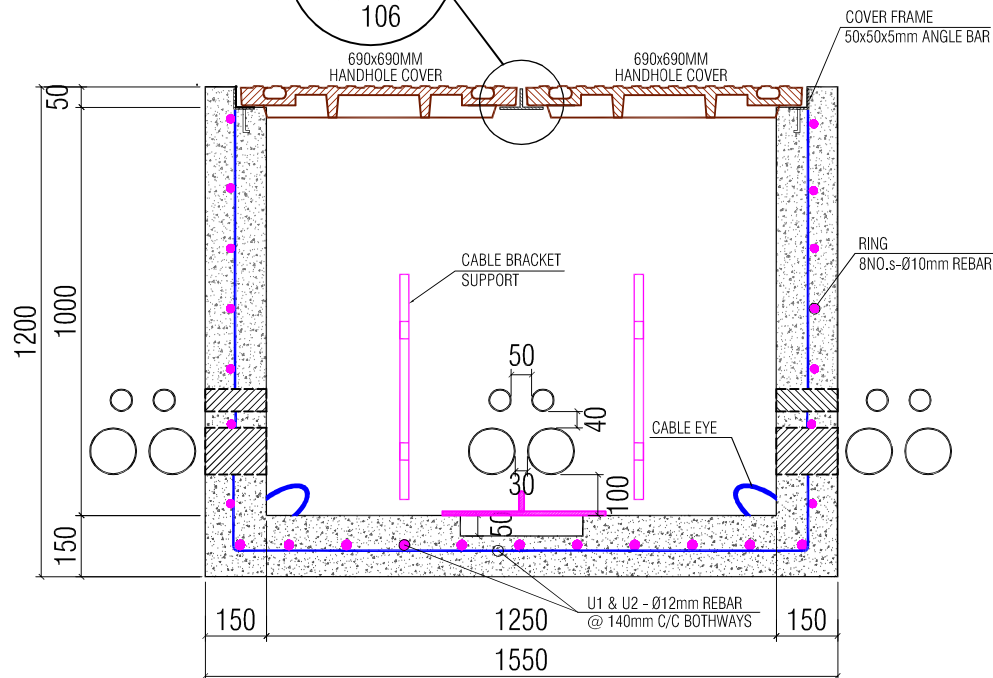
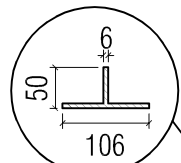

SECTION B

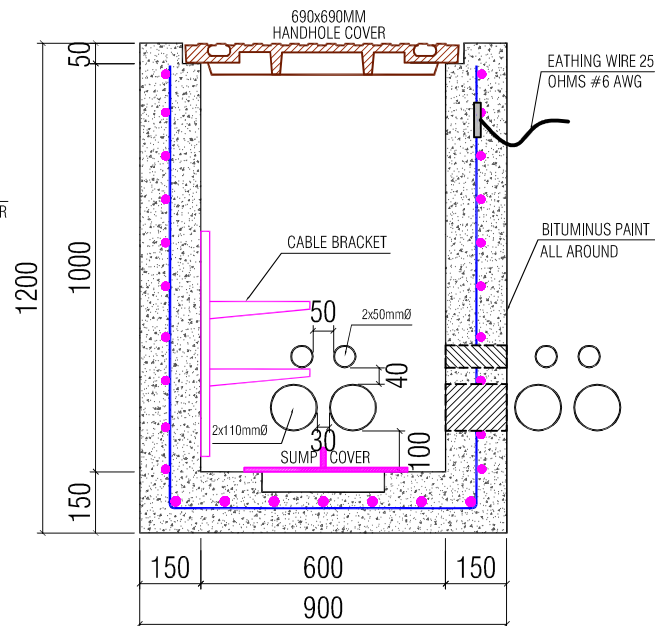

SECTION A

NO.	ACCESSORIES CHECKLIST	QUANTITY
1	SUMP COVER(400mmx400mm)	1 EA
2	CABLE BRACKET SUPPORT(500mm)	2 EA
3	CABLE BRACKET(250mm)	4 EA
4	HANDHOLE COVER-HD(690mmx690mm)	2 EA
5	HANDHOLE FRAME (50mmx50mmx5)	1 EA
6	T-BAR(106MM WIDTH)	1 EA
7	COMPLETE GROUNDING SYSTEM	1 EA
8	PULLING EYE	2 EA
9	MARKING PLATE	1 EA
10	EXPANSION BOLT	4 EA
11	LIFTING BAR	4 EA

NOTES:

- ALL DIMENSIONS ARE IN MILLIMETERS UNLESS OTHERWISE INDICATED.
- CONCRETE CYLINDER COMPRESSIVE STRENGTH SHALL BE MINIMUM OF 4000 PSI AT 28 DAYS.
- CEMENT SHALL BE SULFATE RESISTANT, TYPE V CONFORMING TO ASTM C150.
- STEEL REINFORCEMENTS SHALL CONFORM TO ASTM A615, DEFORMED BARS GRADE 60 WITH MINIMUM YIELD STRENGTH OF 420MPa.
- EXTERNAL SURFACES SHALL BE COATED WITH 2-LAYERS OF BITUMINOUS.
- PRE-FORMED STRUCTURE COVER SHALL BE HEAVY DUTY(H-40).
- HOT DIP GALVANIZED STEEL ACCESSORIES.



Ministry of Interior
Kingdom of Saudi Arabia

MANUFACTURER:

DORAT AL TAL Factory

Tel. No. : 011 466 0408
dorat@dorataltal.com

ENGR:	PROJECT:	SCALE:
CAD:		SCALE
		HOR.
		VERT.
REV. #1	DATE: 03/08/15	DRAWING NO.:
		SHEET NO. 1 OF 1
		DATE:
		CHECKED BY:
		APPROVED BY:
		SIGN:

HANDHOLE TWO COVER FOR MOI (OPTION-2)

LENGTH x WIDTH x HEADROOM
OD : 1550 X 900 X 1200
ID : 1250 X 600 X 1000

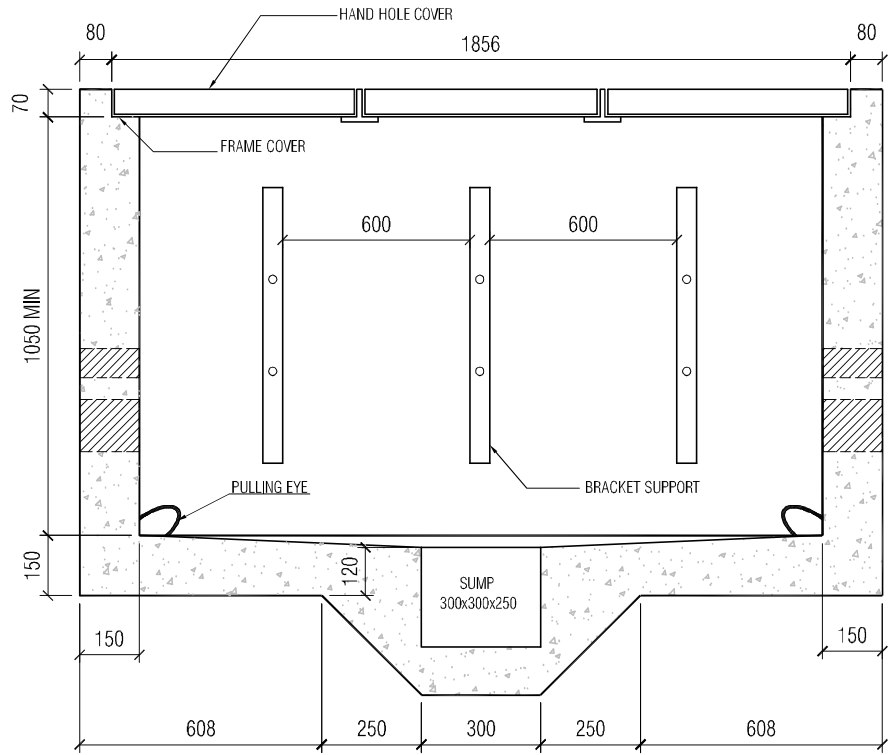

SECTION-AA

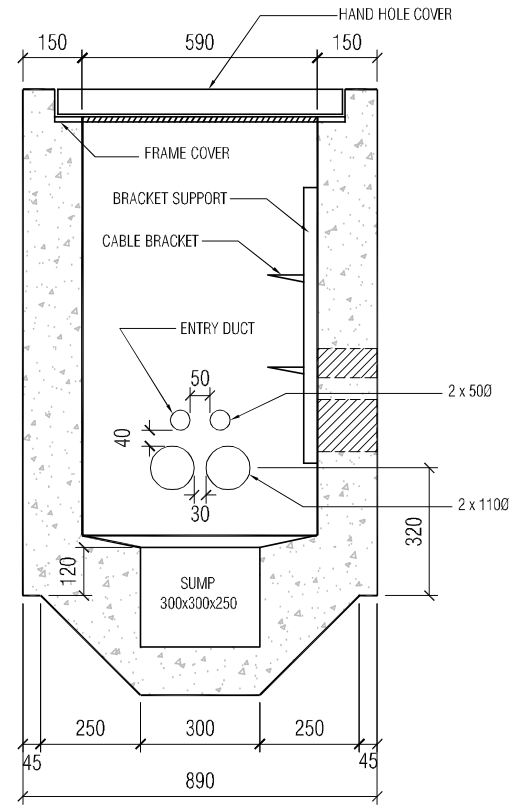

SECTION-BB

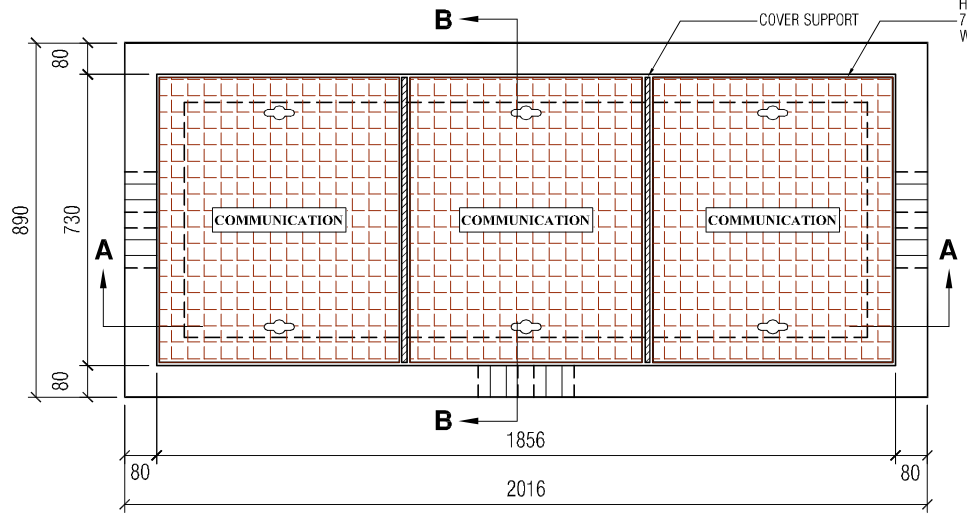

PLAN

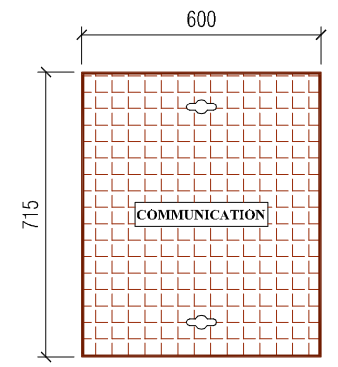

HANDHOLE CI COVER

NO.	ACCESSORIES CHECKLIST	QUANTITY
1	SUMP COVER	1 EA
2	CABLE BRACKET SUPPORT	3 EA
3	CABLE BRACKET	6 EA
4	HANDHOLE COVER-HD	3 EA
5	HANDHOLE FRAME	1 EA
6	T-BAR	2 EA
7	COMPLETE GROUNDING SYSTEM	1 EA
8	PULLING EYE	2 EA
9	MARKING PLATE	1 EA
10	EXPANSION BOLT	6 EA
11	LIFTING BAR	4 EA

NOTES:

- ALL DIMENSIONS ARE IN MILLIMETERS UNLESS OTHERWISE SPECIFIED.
- CONCRETE CYLINDER COMPRESSIVE STRENGTH SHALL BE MINIMUM OF 4000 PSI AT 28 DAYS.
- CEMENT SHALL BE SULFATE RESISTANT, TYPE V CONFORMING TO ASTM C150.
- STEEL REINFORCEMENTS SHALL CONFORM TO ASTM A615 DEFORMED BARS GRADE 60 WITH MINIMUM YIELD STRENGTH OF 420Mpa.
- EXTERNAL SURFACES SHALL BE COATED WITH 2 LAYERS OF BITUMIN
- PRE-FORMED STRUCTURE COVER SHALL BE HEAVY DUTY(H-40)
- HOT DIP GALVANIZED STEEL ACCESSORIES.



Ministry of Interior
Kingdom of Saudi Arabia

MANUFACTURER:



ENGR.:	ENR1	PROJECT:	MIFON	SCALE:	SCALE
CAD:	CAD1			HOR.	
REV. #1	04/04/15			VERT.	
		TITLE:	HANDHOLE THREE COVER FOR MOI (OPTION - 2)	DRAWING NO.	1 OF 1
			LENGTH x WIDTH x HEADROOM	DATE:	
			OD : 2016 X 890 X 1270	CHECKED BY:	
			ID : 1716 X 590 X 1120	APPROVED BY:	
				SIGN:	

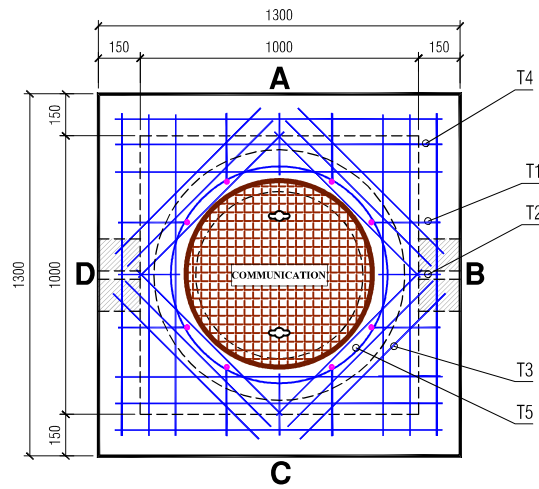

ROOF SLAB REINFORCEMENT

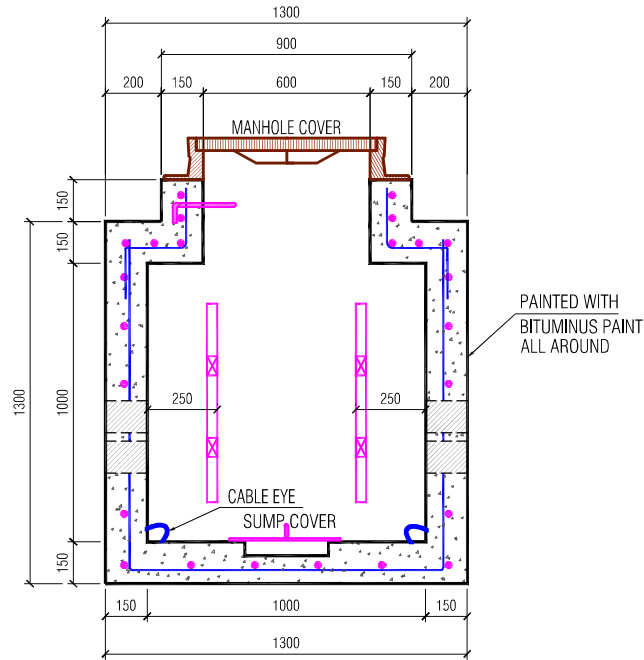

SECTION B-D

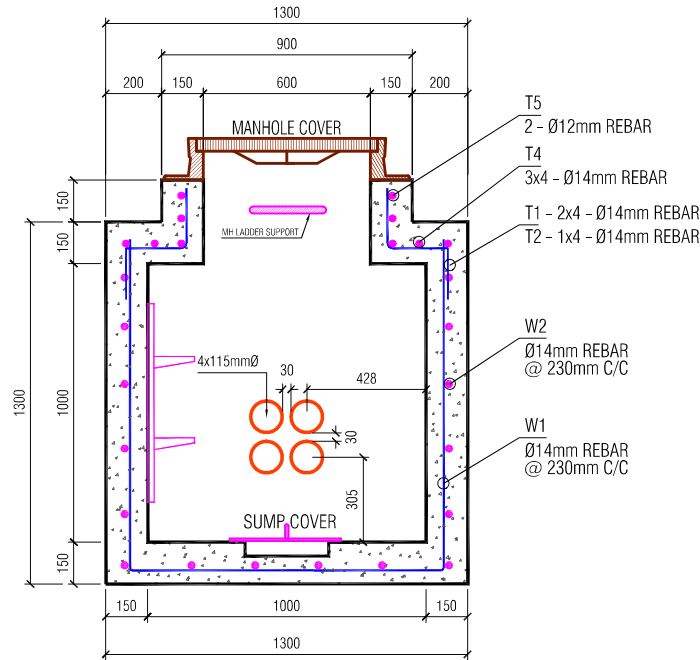

SECTION A-C

REINFORCEMENT SCHEDULE

a	1230	200	200	250	750	1175	2355		
b	1150	1150	250	200		80	150		
c			175						
	W1	T4	T1	T2	T3	W2	T5		
	Ø14mm @ 230mm C/C	3 x 4 Ø14mm	2 x 4 Ø14mm	1 x 4 Ø14mm	3 x 4 Ø14mm	Ø14mm @ 230mm C/C	2-Ø12mm		
	12 NOs	12 NOs	8 NOs	4 NOs	12 NOs	5 NOs	2 NOs		
	RABAR = 126.83 kg					CONCRETE = 1.23cu.m.			

NO.	ACCESSORIES CHECKLIST	QUANTITY
1	SUMP COVER(400mmx400mm)	1 EA
2	CABLE BRACKET SUPPORT(500mm)	2 EA
3	CABLE BRACKET(250mm)	4 EA
4	HEAVY DUTY CAST IRON FRAME & COVER	1 EA
5	COMPLETE GROUNDING SYSTEM	1 EA
6	PULLING EYE	2 EA
7	MARKING PLATE	1 EA
8	WATER STOP	1 EA
9	EXPANSION BOLT	6 EA
10	LADDER	1 EA
11	LADDER SUPPORT	1 EA
12	LIFTING BAR	4 EA

NOTES:

- ALL DIMENSIONS ARE IN MILLIMETERS UNLESS OTHERWISE INDICATED.
- CONCRETE CYLINDER COMPRESSIVE STRENGTH SHALL BE MINIMUM OF 4000 PSI AT 28 DAYS.
- CEMENT SHALL BE SULFATE RESISTANT, TYPE V CONFORMING TO ASTM C150.
- STEEL REINFORCEMENTS SHALL CONFORM TO ASTM A615, DEFORMED BARS GRADE 60 WITH MINIMUM YIELD STRENGTH OF 420MPa.
- EXTERNAL SUFACES SHALL BE COATED WITH 2-LAYERS OF BITUMINOUS.
- PRE-FORMED STRUCTURE COVER SHALL BE HEAVY DUTY(H-40).
- HOT DIP GALVANIZED STEEL ACCESSORIES.



Ministry of Interior
Kingdom of Saudi Arabia

MANUFACTURER:			
ENGR.:	ENGR1	PROJECT:	
CAD:	CAD1	MIFONI II	
REV.	DATE	SIGN	TITLE:
#1	07/08/16		MINI-MANHOLE
			LENGTH x WIDTH x HEADROOM
			OD : 1300 X 1300 X 1300
			ID : 1000 X 1000 X 1000
			SCALE:
			HOR:
			VERT:
			DRAWING NO.
			SHEET NO. 1 OF 1
			DATE:
			CHECKED BY:
			APPROVED BY:
			SIGN:

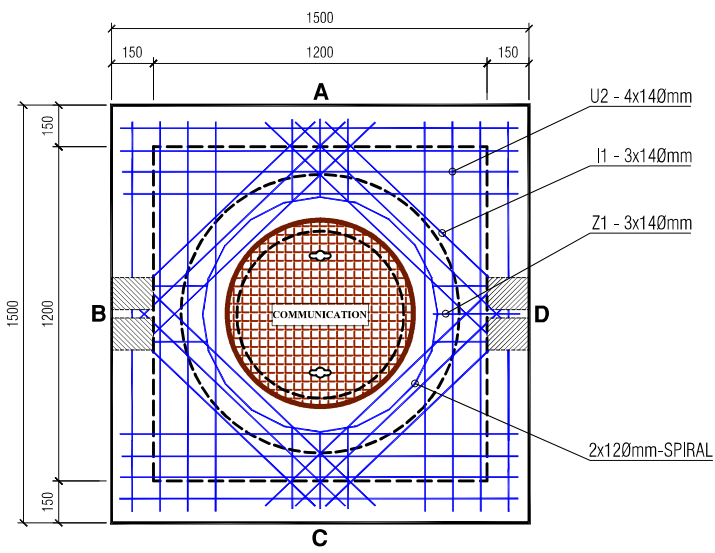

ROOF SLAB REINFORCEMENT

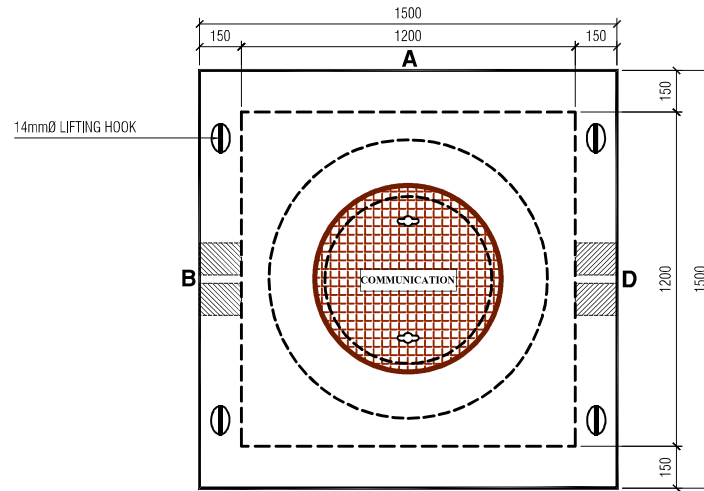

PLAN

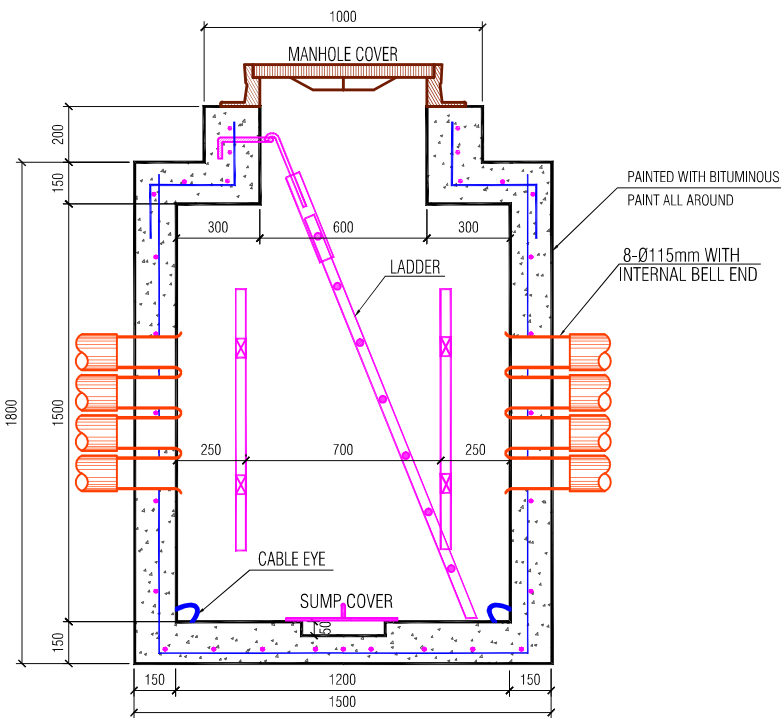

SECTION B-D

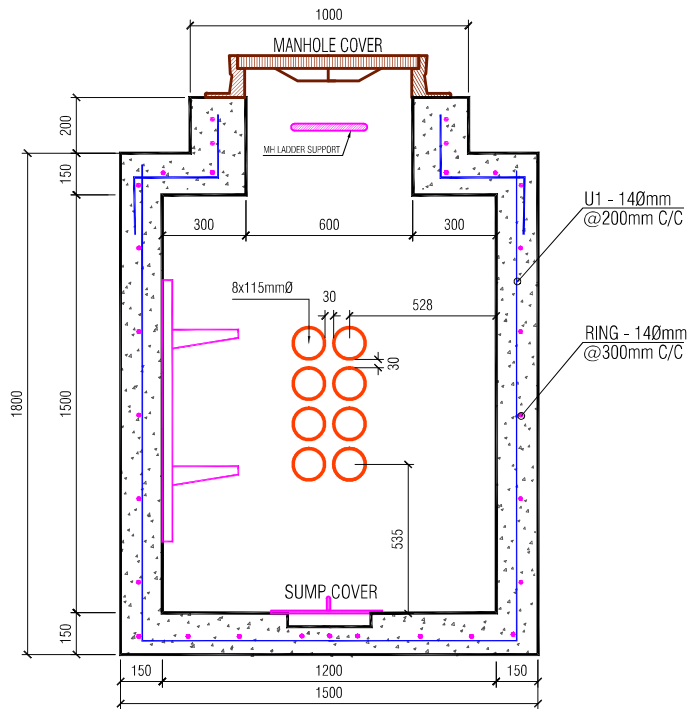

SECTION A-C

REINFORCEMENT SCHEDULE						
ITEM	U1	U2	RING	Z1	I1	SPIRAL
a	1650	200	1380	230	1050	2700
b	1350	1350	100	300		150
c			200			
	140@200mm 7Pcs	4x1-140 16Pcs	140@300mm 6Pcs	3x1-140 12Pcs	3x1-140 12Pcs	2x120 2Pcs
REBAR WT. = 150 Kg.			CONCRETE VOL. = 1.95Cu.M.			

NO.	ACCESSORIES CHECKLIST	QUANTITY
1	SUMP COVER(400mmx400mm)	1 EA
2	CABLE BRACKET SUPPORT(500mm)	2 EA
3	CABLE BRACKET(250mm)	4 EA
4	HEAVY DUTY CAST IRON FRAME & COVER	1 EA
5	COMPLETE GROUNDING SYSTEM	1 EA
6	PULLING EYE	2 EA
7	MARKING PLATE	1 EA
8	WATER STOP	1 EA
9	EXPANSION BOLT	6 EA
10	LADDER	1 EA
11	LADDER SUPPORT	1 EA
12	LIFTING BAR	4 EA

NOTES:

- ALL DIMENSIONS ARE IN MILLIMETERS UNLESS OTHERWISE INDICATED.
- CONCRETE CYLINDER COMPRESSIVE STRENGTH SHALL BE MINIMUM OF 4000 PSI AT 28 DAYS.
- CEMENT SHALL BE SULFATE RESISTANT, TYPE V CONFORMING TO ASTM C150.
- STEEL REINFORCEMENTS SHALL CONFORM TO ASTM A615, DEFORMED BARS GRADE 60 WITH MINIMUM YIELD STRENGTH OF 420MPa.
- EXTERNAL SURFACES SHALL BE COATED WITH 2-LAYERS OF BITUMINOUS.
- PRE-FORMED STRUCTURE COVER SHALL BE HEAVY DUTY(H-40).
- HOT DIP GALVANIZED STEEL ACCESSORIES.



Ministry of Interior
Kingdom of Saudi Arabia

MANUFACTURER:				
ENGR.:	ENGR1	PROJECT:	MIFON II	
CAD:	CAD1	SCALE:	SCALE	
REV. #1	DATE: 07/04/15	SIGN:	DRAWING NO. SHEET NO. 1 OF 1	
TITLE:			MINI-MANHOLE	
LENGTH x WIDTH x HEADROOM			OD : 1500 X 1500 X 1800	
ID :			1200 X 1200 X 1500	
APPROVED BY:			SIGN:	

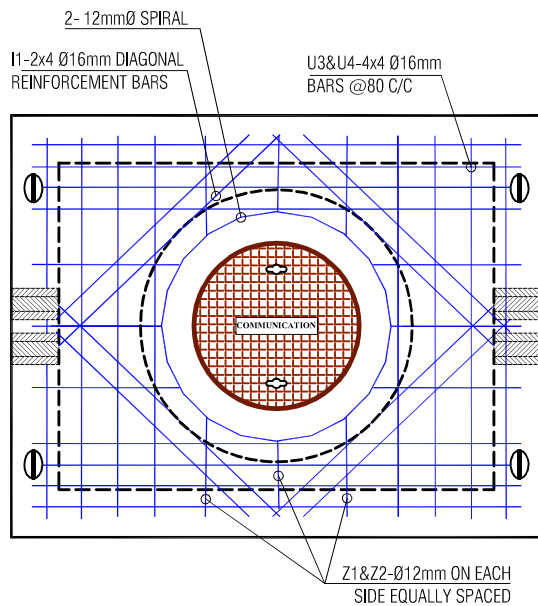

ROOF SLAB REINFORCEMENT

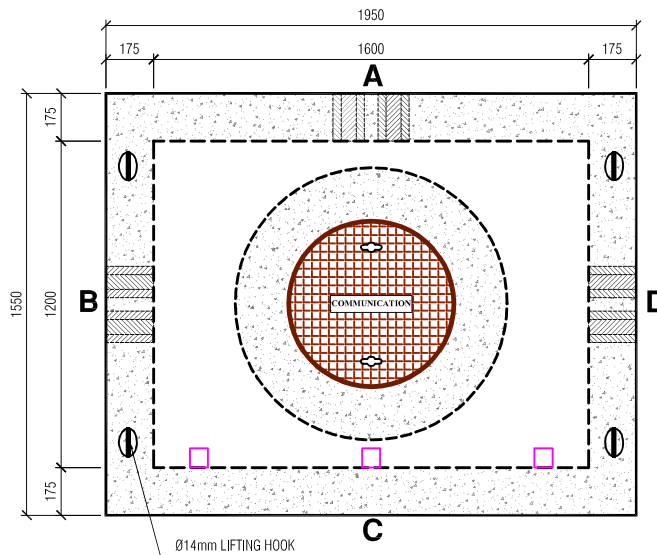

PLAN VIEW

REINFORCEMENT SCHEDULE	ITEM	U1	U2	U3	U4	RING	Z1	Z2	I1	SPIRAL	CONCRETE VOL. = 2.76Cu.M.	REBAR WT. = 253 Kg.
a	1700	1700	200	200	200	1430	230	230	1250	2700	2x120	2Pcs
b	1800	1400	1800	1400	1400	1830	380	260	250	150	2x160	8Pcs
c	140@200mm	4x4	160	140@200mm	120	100	250	250	250	2x120	2x120	2Pcs
		7Pcs	9Pcs	8Pcs	8Pcs	9Pcs	8Pcs	4Pcs	8Pcs	8Pcs	8Pcs	8Pcs

NO.	ACCESSORIES CHECKLIST	QUANTITY
1	SUMP COVER(400mmx400mm)	1 EA
2	CABLE BRACKET SUPPORT(500mm)	3 EA
3	CABLE BRACKET(250mm)	9 EA
4	HEAVY DUTY CAST IRON FRAME & COVER	1 EA
5	COMPLETE GROUNDING SYSTEM	1 EA
6	PULLING EYE	2 EA
7	MARKING PLATE	1 EA
8	WATER STOP	1 EA
9	EXPANSION BOLT	9 EA
10	LADDER	1 EA
11	LADDER SUPPORT	1 EA
12	LIFTING BAR	4 EA

NOTES:

1. ALL DIMENSIONS ARE IN MILLIMETERS UNLESS OTHERWISE INDICATED.
2. CONCRETE CYLINDER COMPRESSIVE STRENGTH SHALL BE MINIMUM OF 4000 PSI AT 28 DAYS.
3. CEMENT SHALL BE SULFATE RESISTANT, TYPE V CONFORMING TO ASTM C150.
4. STEEL REINFORCEMENTS SHALL CONFORM TO ASTM A615, DEFORMED BARS GRADE 60 WITH MINIMUM YIELD STRENGTH OF 420MPa.
5. EXTERNAL SURFACES SHALL BE COATED WITH 2-LAYERS OF BITUMINOUS.
6. PRE-FORMED STRUCTURE COVER SHALL BE HEAVY DUTY(H-40).
7. HOT DIP GALVANIZED STEEL ACCESSORIES.

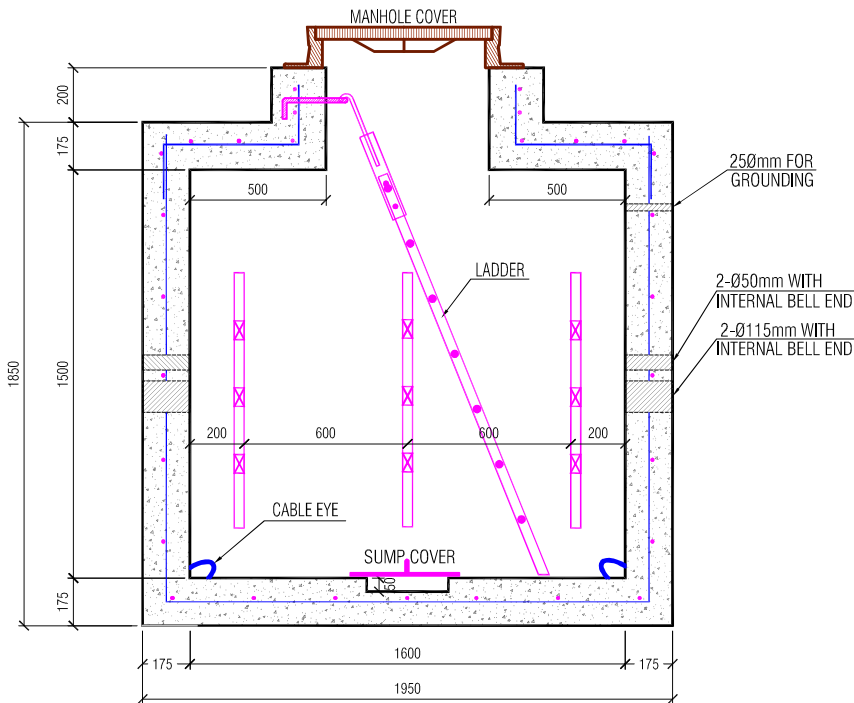

SECTION B-D

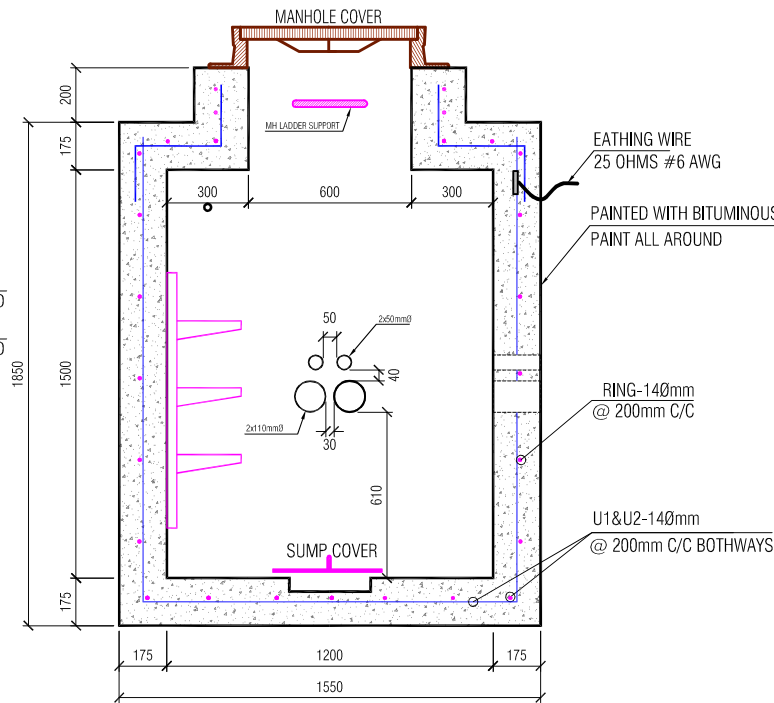

SECTION A-C



Ministry of Interior
Kingdom of Saudi Arabia

MANUFACTURER:

DORAT AL TAL Factory

Tel. No.: 011 466 0408
dorat@dorataltal.com

ENGR:	PROJECT:	SCALE:
CAD:		SCALE
REV:	DATE:	FOR:
#1	03/08/15	VERT.
		DRAWING NO.
		SHEET NO. 1 OF 1
		DATE:
		CHECKED BY:
		APPROVED BY:
		SIGN:

LENGTH x WIDTH x HEADROOM
OD : 1950 X 1550 X 1850
ID : 1600 X 1200 X 1500

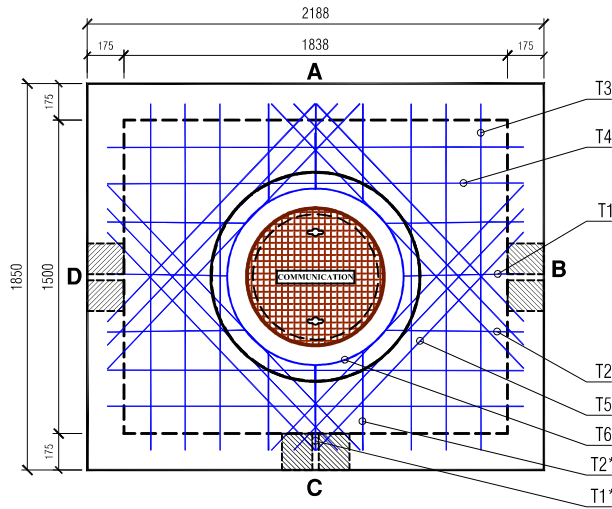

ROOF SLAB REINFORCEMENT

REINFORCEMENT SCHEDULE											
a		a		a		c		b		a	
a	2225	2225	200	200	1600	225	225	225	225	2035	2765
b	2010	1650	1650	2010		620	450	715	525	1700	200
c						200	200	200	200	80	
W1	W2	T3	T4	T5	T1	T1*	T2	T2*	W3	T6	
14mmØ @200mm C/C	14mmØ @200mm C/C	3x2 14mmØ	2x2 14mmØ	3x4 14mmØ	1x2 14mmØ	1x2 14mmØ	2x2 14mmØ	2x2 14mmØ	14mmØ @300mm C/C	2-12mmØ	
9 NOs	11 NOs	6 NOs	4 NOs	12 NOs	2 NOs	2 NOs	4 NOs	4 NOs	9 NOs	2 NOs	
REBAR = 305 kg						CONCRETE = 4.15 cu.m.					

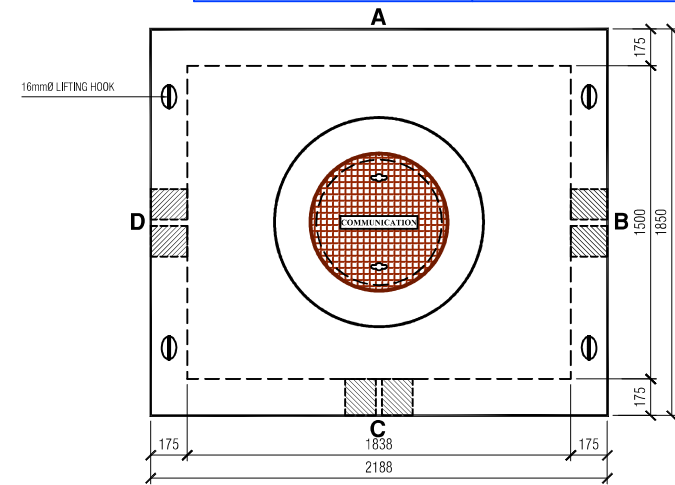

PLAN

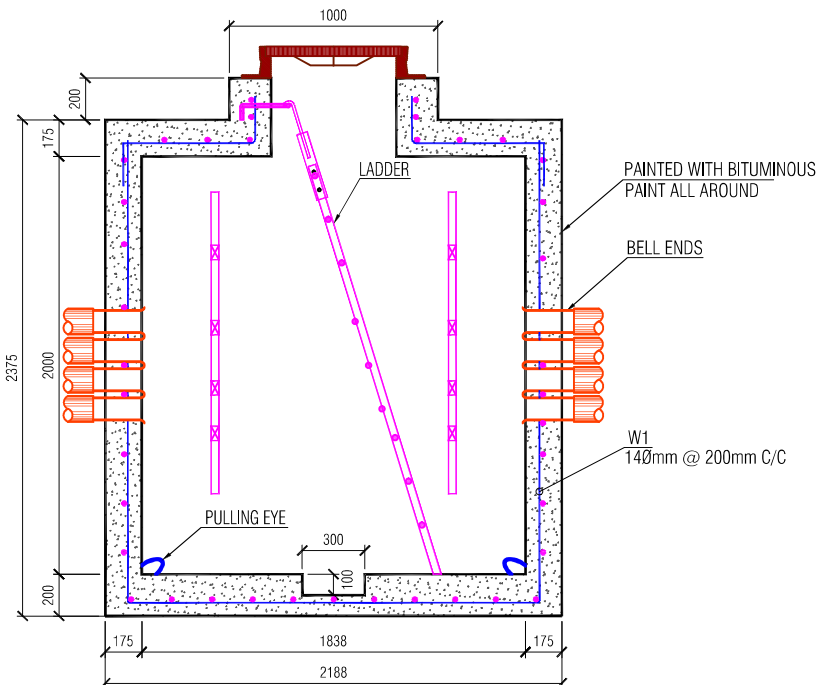

SECTION B-D

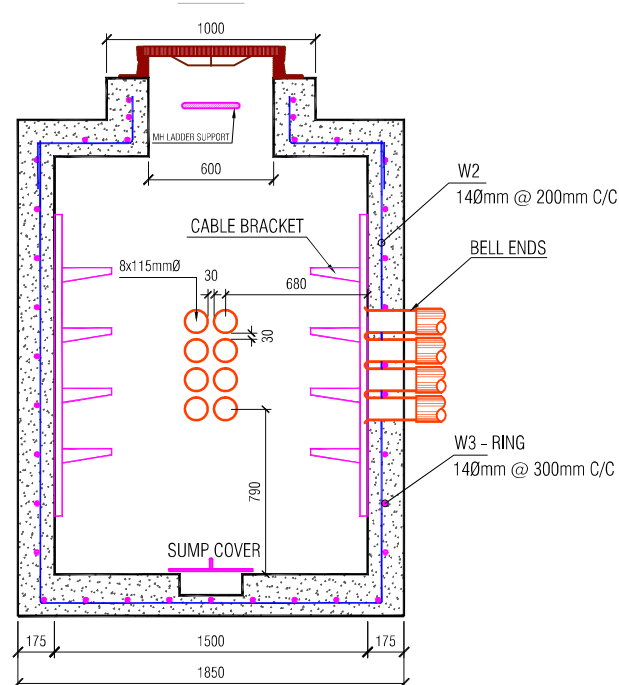

SECTION A-C

NO.	ACCESSORIES CHECKLIST	QUANTITY
1	SUMP COVER(400mmx400mm)	1 EA
2	CABLE BRACKET SUPPORT(500mm)	4 EA
3	CABLE BRACKET(250mm)	16 EA
4	HEAVY DUTY CAST IRON FRAME	1 EA
5	HEAVY DUTY CAST IRON COVER	1 EA
6	PULLING EYE	2 EA
7	MARKING PLATE	1 EA
8	EXPANSION BOLT	12 EA
9	LADDER	1 EA
10	LADDER SUPPORT	1 EA
11	LIFTING BAR	4 EA

NOTES:

- ALL DIMENSIONS ARE IN MILLIMETERS UNLESS OTHERWISE INDICATED.
- CONCRETE CYLINDER COMPRESSIVE STRENGTH SHALL BE MINIMUM OF 4000 PSI AT 28 DAYS.
- CEMENT SHALL BE SULFATE RESISTANT, TYPE V CONFORMING TO ASTM C150.
- WALLS EXPOSE TO EARTH SHALL BE COATED WITH APPROVED BITUMINOUS MATERIAL.
- REINFORCEMENT BARS SHALL CONFORM TO ASTM A615, GRADE 60.
- PRE-FORMED STRUCTURE COVER SHALL BE HEAVY DUTY(H-40).
- ALL METAL PARTS OF THE MANHOLES ACCESSORIES SHALL BE PROTECTED AGAINST CORROSION.



Ministry of Interior
Kingdom of Saudi Arabia

MANUFACTURER:					
ENGR.:	ENGR1	PROJECT:	MIFON II		
CAD:	CAD1	SCALE:	SCALE		
REV. #1	DATE: 07/04/15	SIGN:	DRAWING NO. SHEET NO. 1 OF 1		
TITLE:			SERVICE MANHOLE		
LENGTH x WIDTH x HEADROOM			OD : 2188 X 1850 X 2375		
ID : 1838 X 1500 X 2000			DATE: CHECKED BY: APPROVED BY: SIGN:		

Saudi Electricity Company
CTA Projects Department

Approved SIGN: ENGR. WALEED ALSHARAH
Approved with Comments
Disapproved
DATE: 24/12/2011
SFC Ref & Date: 0304000-005-0729
Dt: 05/12/2011

- NOTES**
- ALL DIMENSIONS ARE IN MILLIMETERS UNLESS OTHERWISE NOTED.
 - REINFORCING STEEL SHALL BE DEFORMED BARS CONFORMING TO SASO SASO/2/1992, WITH A YIELD STRESS OF 420 MPa. DEFORMATIONS SHALL BE PER ASTM A615M.
 - SPLICES OF STEEL REINFORCEMENT SHALL BE IN ACCORDANCE WITH ACI 318M.
 - MINIMUM COVER OF STEEL REINFORCEMENT SHALL SATISFY THE REQUIREMENTS OF 70-TMSS-03 AND ACI 318M.
 - STEEL REINFORCEMENT AROUND THE SUMP SHALL BE BENT TO PROVIDE ADEQUATE CONCRETE COVER OVER THE REINFORCEMENTS.
 - UNLESS SPECIFIED, CONCRETE TO BE USED SHALL BE CONCRETE FOR SEVERE EXPOSURE CONFORMING TO SEC MATERIALS STANDARD SPECIFICATION 70-TMSS-03.
 - PULLING EYES SHALL BE INSTALLED IN THE WALLS OPPOSITE EACH CABLE DUCT OPENINGS AS SHOWN IN THE DRAWING. PULLING EYES SHALL BE GALVANIZED IN ACCORDANCE WITH ASTM A123.
 - STEEL REINFORCEMENTS SHALL NOT BE HEATED FOR THE PURPOSED OF FIELD BENDING.
 - ALL CABLE DUCTS TERMINATING INSIDE THE HAND-HOLE SHALL BE EQUIPPED WITH BELL END INSTALLED FLUSH WITH THE INTERIOR FACE OF THE WALL. BOTH EMPTY AND OCCUPIED CABLE DUCTS SHALL BE SEALED WITH DUCT SEALING UNIT CONFORMING TO 23-TMSS-02.
 - THE CABLE DUCTS SHALL BE CLASS IV STRENGTH FOR TYPE DB DIRECT BURIED AND CLASS III FOR TYPE EB CONCRETE ENCASE CONFORMING TO SASO/14/1998 AND 23-TMSS-01.
 - HANDHOLE SLAB AND WALL SHALL BE CASTED MONOLITHIC. CONSTRUCTION JOINTS SHALL BE PROVIDED WITH PVC WATER STOP TO ENSURE WATER TIGHTNESS OF JOINTS, IF APPLICABLE.
 - PRECAST HANDHOLE SHALL BE PLACED ON LEVEL 100mm THICK LEAN CONCRETE, WHICH IS PLACED OVER A WELL COMPACTED SELECT FILL OF 200mm DEPTH, PROVIDE +300mm EXTRA DIMENSION ALL AROUND THE PRECAST HANDHOLE AT THE BASE FOR CENTERING DURING INSTALLATION.

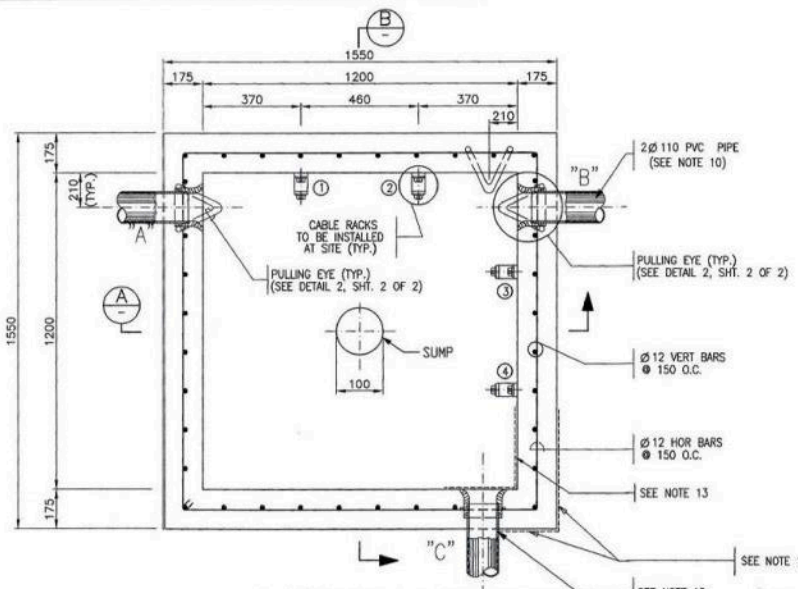

HANDHOLE DETAIL PLAN

- NOTE:**
- FOR STRAIGHT RUN CONDUIT MARKED "C" AND CABLE RACK MARKED ① AND ② SHALL BE DELETED
 - FOR CORNER HANDHOLE, DELETE CONDUIT MARKED "B"

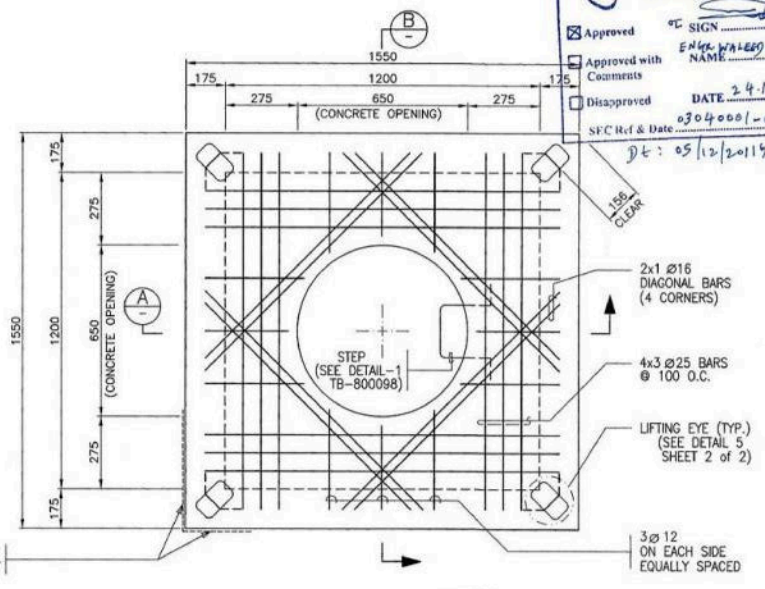

HANDHOLE ROOF SLAB REINFORCEMENT

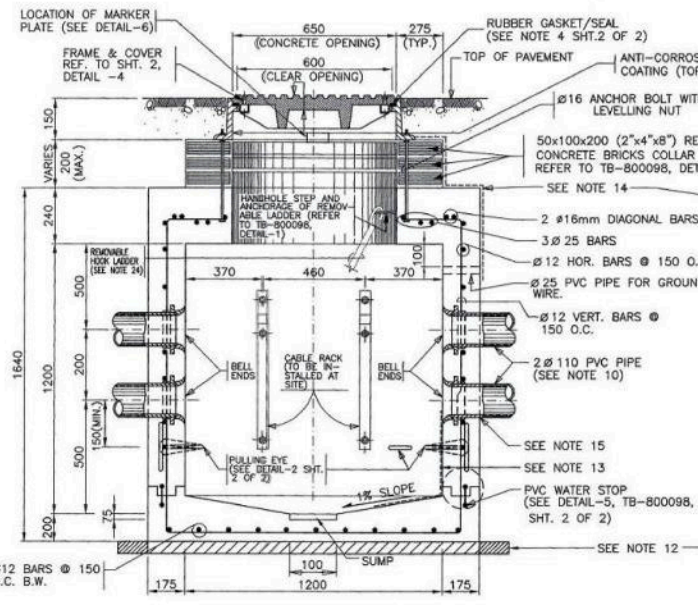

SECTION THRU "A"

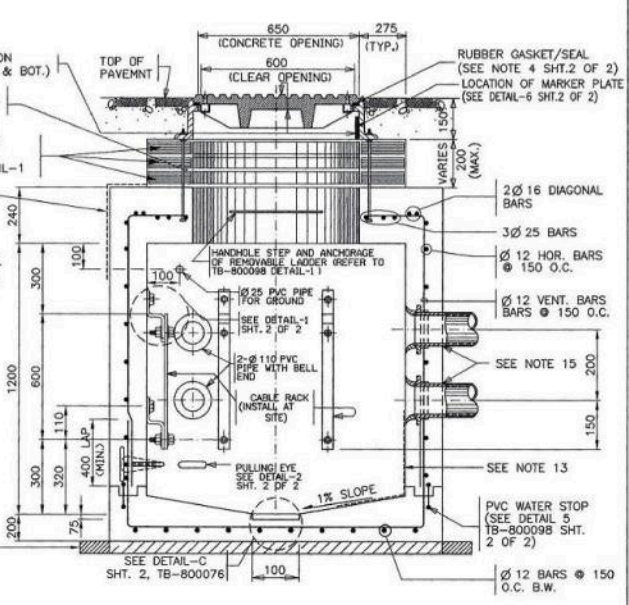

SECTION THRU "B"

NOTES (CONT.)

- ALL INTERIOR SURFACES OF HANDHOLE SHALL BE COATED WITH ELASTOMERIC CEMENTITIOUS IMPERMEABLE MEMBRANE, WITH MINIMUM WET FILM THICKNESS OF 1mm.
- WATERPROOFING OF COMMUNICATION HANDHOLE SHALL BE PER DRAWING TB-800098.
- CABLE DUCTS INTERFACE WITH CONCRETE SHALL BE SEALED WITH APPROVED JOINT SEALANT PRIOR TO WATERPROOFING.
- ALL VOIDS AROUND LIFTING EYES SHALL BE FILLED WITH NON-SHRINK GROUT AFTER INSTALLATION OF HANDHOLE AT SITE.
- GROUNDING INSTALLATION AND GROUND RESISTANCE TEST PER DRAWING No. TB-800098 AND TES-P-119.10 SHALL BE CONDUCTED RESPECTIVELY PRIOR TO BACK FILLING AND REINSTATEMENT. GROUND RESISTANCE SHALL BE MAXIMUM 25 OHMS.
- CONTACTOR SHALL CLEAN THE DUCTS AND HANDHOLE TO THE SATISFACTION OF SEC INSPECTOR AFTER INSTALLATION.
- CONTRACTOR SHALL INFORM THE COMPANY REPRESENTATIVE FOR ANY CONSTRUCTION OBSTRUCTION OR DEVIATION FROM THE SPECIFICATIONS AND DRAWINGS.
- THE CONTRACTOR MAY CONSTRUCT THE HANDHOLE CAST-IN-PLACE UPON APPROVAL BY THE SEC INSPECTOR.
- PRECAST HANDHOLE SHALL BE HANDLED AND TRANSPORTED BY THE CONTRACTOR TO ITS FINAL POSITION IN A PROFESSIONAL MANNER TO PREVENT DAMAGE. ANY DAMAGE SHALL BE THE RESPONSIBILITY OF THE CONTRACTOR TO REPAIR.
- THE DUCT FORMATION SHALL BE TRANSFORMED FROM HORIZONTAL TO VERTICAL CONFIGURATION, STARTING 10 METERS FROM THE HANDHOLE WALL.
- HANDHOLE SHALL BE USED ONLY FOR 2-DUCTS CONFIGURATION. FOR 4 OR MORE DUCTS, USE HANDHOLE PER DRAWINGS TA-800098 OR TA-800097 AS NEEDED.
- REMOVABLE HOOK LADDER TO BE PROVIDED ON END HANDHOLE. HANDHOLES WITH SPLICE AND TWO (2) SPARE REMOVABLE HOOK LADDER FOR EACH LINES, SEE DRAWING TB-800098 DETAIL-B.

REFERENCE DRAWINGS

DRAWING TITLE	DRAWING NO.
DRAWING CONTROL SHEET	CE-232841
MANHOLE/HANDHOLE ACCESSORIES (COMMUNICATIONS)	TB-800098

ISSUED FOR BASE DESIGN

AS-BUILT BY	DATE

REV. NO.	DATE	BY	DESCRIPTION	CHKD.	CERT.	APPD.
A	25.10.11	EBY	ISSUED FOR BASE DESIGN	UC	KSJ	

الشركة السعودية للكهرباء
Saudi Electricity Company

DRAWN BY: EBY CHECKED BY: U.CLEMENT SCALE AS SHOWN
DATE STARTED: 23.10.11 DATE COMPLETED: 13-01-15
OPR'G. DEPT. ENG. DEPT. 13-01-15

APPROVAL/CERTIFICATION INFORMATION
THIS DRAWING IS NOT TO BE USED FOR CONSTRUCTION OR FOR ORDERING MATERIAL UNLESS CERTIFIED AND DATED DOC. NO. REV. 10-02-15

COMMUNICATION HANDHOLE DETAILS
PROPOSED 132kV U/G CABLE ROUTE FROM EXISTING S/S #114 TO S/S #8005 & 8000
REPLACEMENT PORTION OF 132kV D/C OHL ON KHALID BIN WALID ROAD
RIYADH SAUDI ARABIA

THIS DRAWING AND THE INFORMATION CONTAINED HEREIN ARE THE SOLE PROPERTY OF SAUDI ELECTRICITY CO. NO REPRODUCTION IN FULL OR IN PART SHALL BE OBTAINED FROM THIS DOCUMENT WITHOUT THE WRITTEN CONSENT OF ITS OWNER.

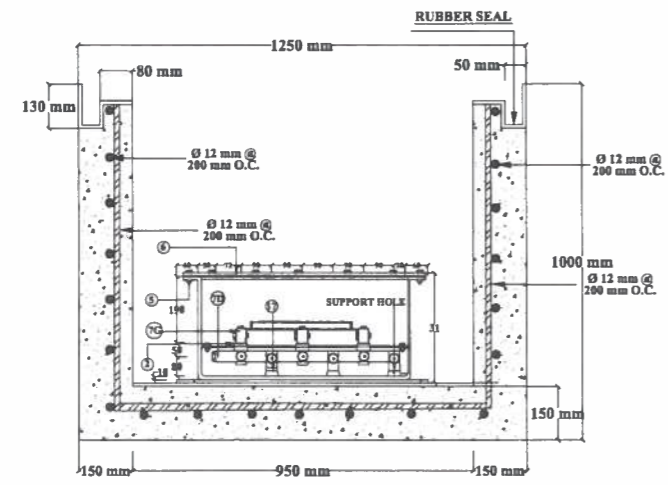
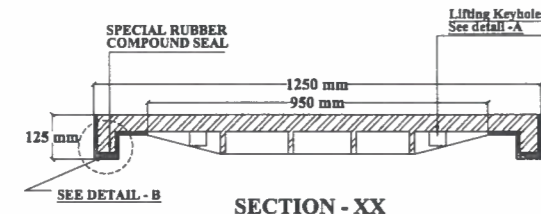
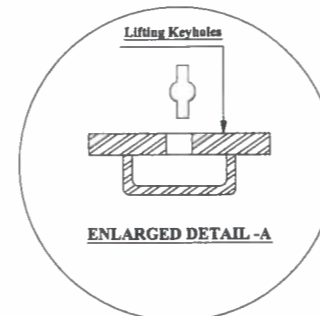
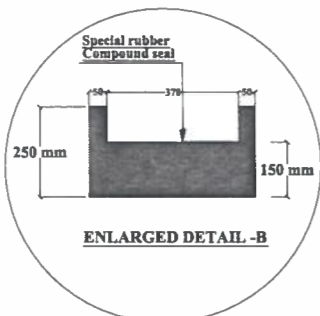

SECTION WIDE FRAME DETAILS

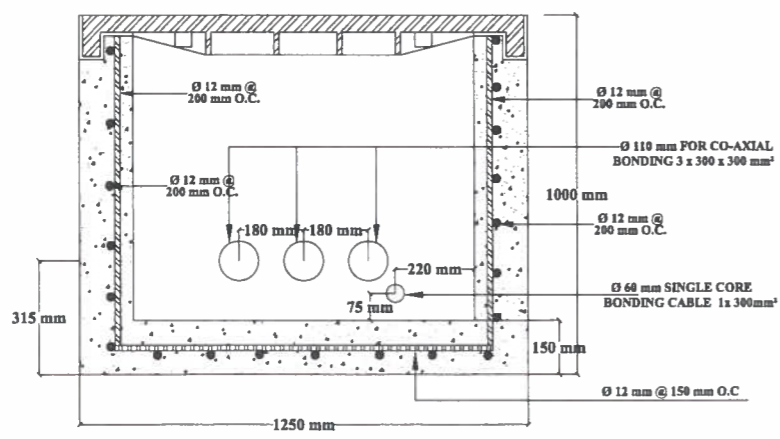

REINFORCEMENT DETAILS

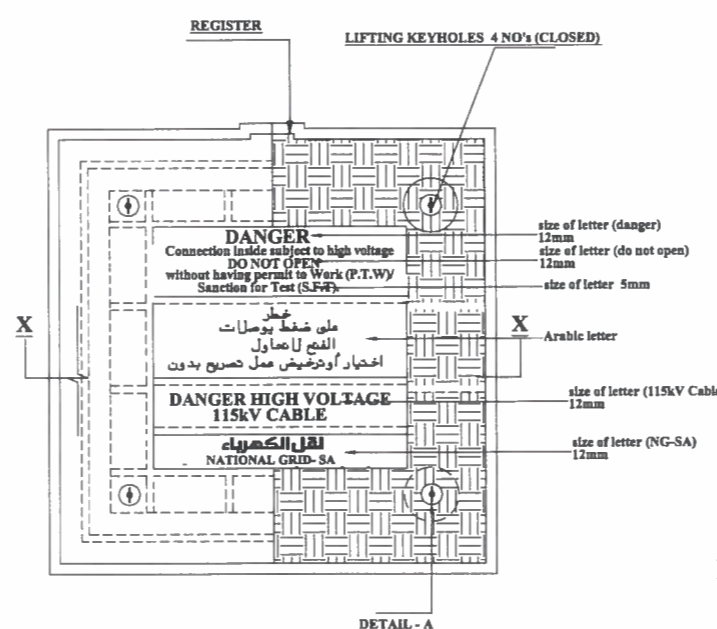

CAST IRON COVER TOP VIEW

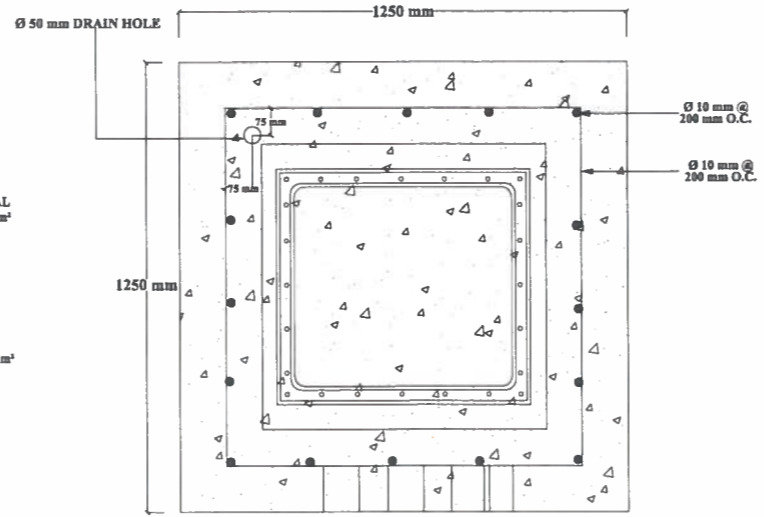

PLAN VIEW

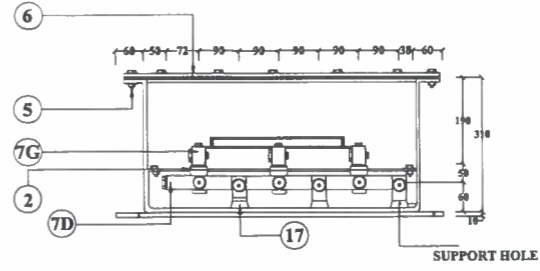

SECTION - B

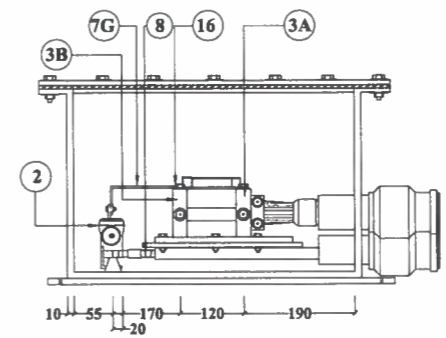

SECTION - A

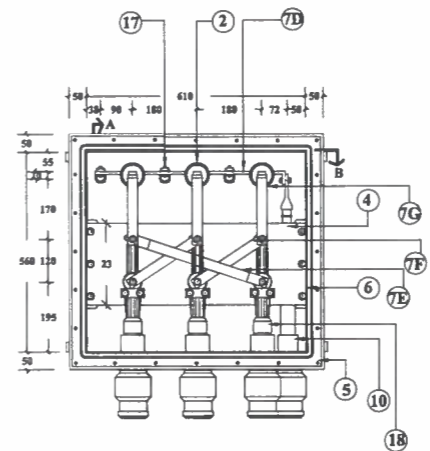

TOP VIEW ELEVATION

S.NO	NAME OF PARTS	QTY
1.	FIBER GLASS LINK BOX	1
2.	S.V.L	3
3A	TINNED CONNECTOR COPPER	3
3B	TINNED CONNECTOR COPPER	3
4.	INSULATOR PLATE 600 mm x 230 mm	1
5.	FLAT RUBBER GASKET 4 mm x 25mm x 2500 mm	1
6.	ROUND RUBBER GASKET 6 mm x 2485 mm	1
7D.	TINNED LINK COPPER GROUND BAR 10mm x 30mm x 582mm	1
7E.	TINNED LINK COPPER GRD. BAR 10 mm x 30 mm x 40/430 mm	1
7F.	TINNED LINK COPPER GRD BAR 10 mm x 30 mm x 257 mm	2
7G.	TINNED LINK COPPER GRD BAR 10 mm x 30 mm x 60 / 180 mm	3
8.	TINNED GROUND CONNECTOR COPPER SIZE 300 mm	1
10.	FIBER PIPE (OPEN SIZE)	4
11.	WATER SEAL (SPECIAL)	4
12.	WATER PROOF MASTIC TAPE	1
14.	SHIRNK TUBE	4
15.	P.V.C. TAPE	1
16.	STANDARD NUTS NO.12 mm (COMPLETE SET)	4
17.	STAINLESS STEEL SUPPORT 10 mm x 3 mm x 46/50 mm	3
18.	COLOR MARKING TUBE	3

- NOTES
- ALL DIMENSIONS ARE IN MILLIMETRS UNLESS OTHERWISE NOTED.
 - CEMENT USED SHALL BE SULPHATE TYPE V CONFIRMING TO ASTM 150.
 - REINFORCEMENT SHALL BE DEFORMED STEEL BARS CONFORMING TO ASTM 615 OR GRADE 60.
 - APPLY TWO COATS DAMP PROOFING AT EXTERNAL WALLS.
 - THE LINK BOX FRAME AND COVER SHALL BE MADE OF HEAVY DUTY CAST IRON FOR 45 TONS MOVING LOAD.
 - THE COVER SHALL CASTED WITH APPROVED MONOGRAM.
 - THE CI STEEL COVER SHALL BE FINISHED WITH BLACK EPOXY COATING.
 - MINIMUM COMPRESSIVE STRNGTH OF CONCRETE AT 28 DAYS SHALL BE 38 MPA.

LEGEND

FINISH OF THE COVER.
BLACK PROXY PAINTING.

DRAWING TITLE	DRAWING NO.
SCOPE OF WORK & TECHNICAL SPECIFICATION(PTS)	13EC 1010
DRAWING CONTROL SHEET NO.	EE-365567

PROPOSED BY METS DATE 05-02-2015

05-02-2015	METS	CONCRETE MAN HOLE WITH COVER FOR LINK BOX	ENGR VICENTE	ENGR JUMAYT	ENGR AYUB
REV. NO.	DATE	BY	DESCRIPTION	CHKD.	CERT. APPD.



DRAWN BY DKB CHECKED BY ENGR JUANITO SCALE NTS
DATE STARTED _____ DATE COMPLETED _____
OPR'G. DEPT. _____ ENG. DEPT. _____

THIS DRAWING IS NOT TO BE USED FOR CONSTRUCTION OR FOR ORDERING MATERIAL UNTIL CERTIFIED AND DATED

APPROVAL/CERTIFICATION INFORMATION
DOC NO. _____ REV. NO. _____
CONCRETE MAN HOLE WITH COVER & LINK BOX
CONVERSION OF 115kV OHTL MASQUDI/ANDALUS/
KHALIDIYAH TO UNDER GROUND CABLES IN AL HASSA

CONTRACT NO.	INDEX	PLANT NO.	DRAWING NUMBER	SHEET NO.	REV. NO.
4400004093	A	T599	EE-365628	01 of 01	00

SEC-B (2/084/10)
DMS VECTOR SEC808
17/10/15

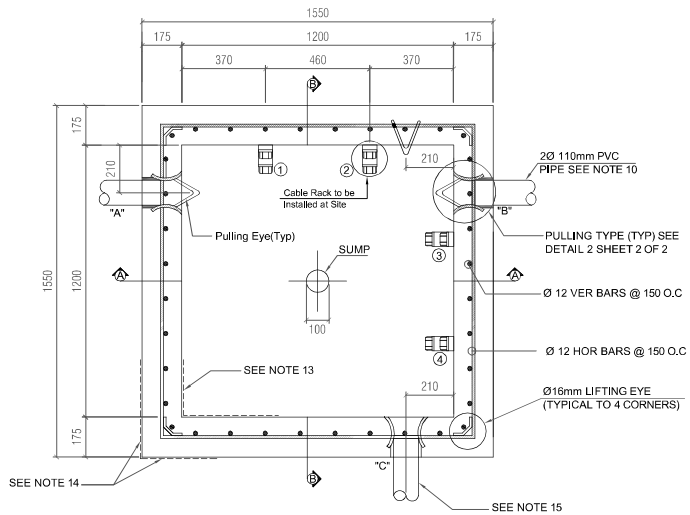

HAND HOLE DETAIL PLAN

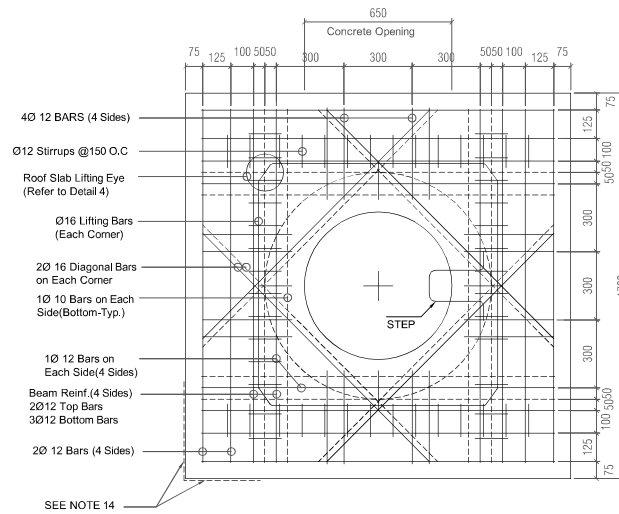

HANDHOLE ROOF SLAB REINFORCEMENT

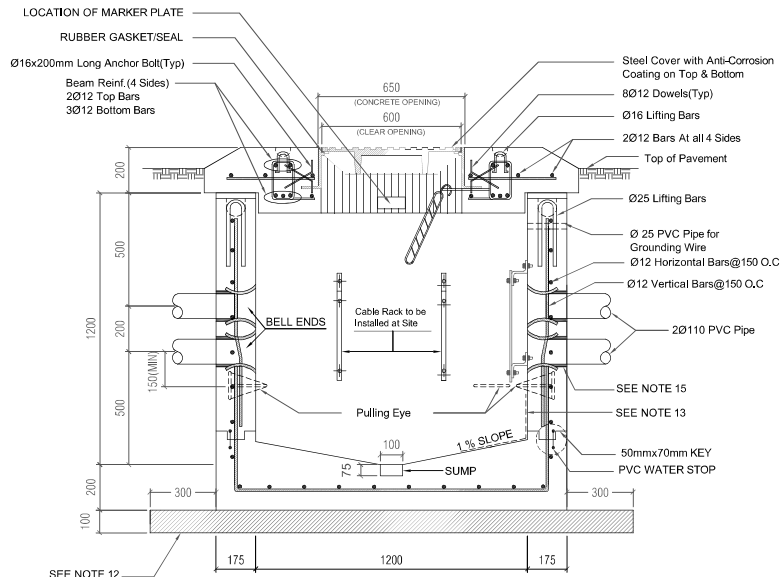

SECTION THRU-'A'

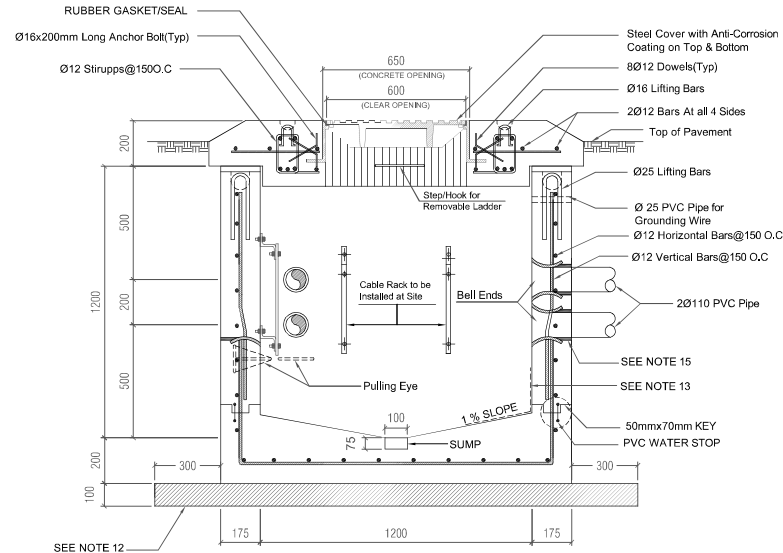

SECTION THRU-'B'

NOTES:

1. ALL DIMENSIONS ARE IN MILLIMETERS UNLESS OTHERWISE NOTED.
2. REINFORCEMENT STEEL SHALL BE DEFORMED BARS CONFORMING TO SASO SASO/2/1992. WITH A YIELD STRESS OF 420 MPa. DEFORMATIONS SHALL BE PER ASTM A615M.
3. SPLICES OF STEEL REINFORCEMENT SHALL BE IN ACCORDANCE WITH ACT 318 M.
4. MINIMUM COVER OF STEEL REINFORCEMENT SHALL SATISFY THE REQUIREMENTS OF 70-TMSS-03 AND ACT 318M
5. STEEL REINFORCEMENT AROUND THE SUMP SHALL BE BENT TO PROVIDE ADEQUATE CONCRETE COVER OVER THE REINFORCEMENT.
6. UNLESS SPECIFIED, CONCRETE TO BE USED SHALL BE CONCRETE FOR SEVERE EXPOSURE CONFIRMING TO SEC MATERIALS STANDARDS SPECIFICATIONS 70-TMSS-03
7. PULLING EYES SHALL BE INSTALLED IN THE WALLS OPPOSITE EACH OTHER CABLE DUCT OPENINGS AS SHOWN IN THE DRAWING, PULLING EYES SHALL BE GALVANIZED IN ACCORDANCE WITH ASTM A123.
8. STEEL REINFORCEMENT SHALL NOT BE HEATED FOR THE PROPOSE OF FIELD BENDING.
9. ALL CABLE DUCT SHALL TERMINATING INSIDE THE HANDHOLE SHALL BE EQUIPPED WITH BELL END INSTALLED FLUSHED WITH THE INTERIOR FACE OF THE WALL BOTH EMPTY & OCCUPIED CABLE DUCT SHALL BE SEALED WITH DUCT SEALING UNIT CONFORMING TO 23-TMSS-01
10. THE CABLE DUCTS SHALL BE CLASS IV STRENGTH FOR TYPE DB DIRECT BURRIED AND CLASS III FOR TYPE EB CONCRETE ENCASE CONFORMING TO SASO /14/1998 AND 23-TMSS-01
11. HANDHOLE SLAB AND WALL SHALL BE CAST MONOLITHIC CONSTRUCTION JOINTS SHALL BE PROVIDED WITH PVC WATER STOP TO ENSURE WATER TIGHTNESS OF JOINTS IF APPLICABLE.
12. PRECAST HANDHOLE SHALL BE PLACED ON LEVEL 100MM THICK LEAN CONCRETE WHICH IS PLACED OVER HAVEL COMPACTED SELECT FILL OF 200MM DEPTH, PROVIDE PLUS 300MM EXTRA DIMENSION ALL AROUND THE PRECAST HANDHOLE AND THE BASE PER CENTERING DURING INSTALLATION.
13. ALL INTERIOR SURFACES OF HANDHOLES SHALL BE COATED WITH ELASTOMERIC CEMENTITIOUS IMPERMEABLE MEMBRANE WITH MINIMUM WEIGHT FILL THICKNESS OF 1MM.
14. WATERPROOFING OF COMMUNICATION HANDHOLES SHALL BE PER DRAWING TB-800098
15. CABLE DUCTS INTERFACE WITH CONCRETE SHALL BE SEALED WITH APPROVED JOINT SEALANTS PRIOR TO WATERPROOFING
16. ALL VOIDS AROUND LIFTING EYES SHALL BE FILLED WITH NON SHRINK GROUT AFTER INSTALLATION OF HANDHOLE AT SITE.
17. GROUNDING INSTALLATION AND GROUND REINSTATEMENT TEST PER DRAWING TB-800098 AND TES-P-119.10 SHALL BE CONDUCTED RESPECTIVELY PRIOR TO BACKFILLING AND REINSTATEMENT GROUND RESISTANCE SHALL BE MAXIMUM 25 OHMS.
18. CONTRACTOR SHALL BE CLEAN THE DUCTS AND HANDHOLE TO THE SATISFACTION OF SEC INSPECTOR AFTER INSTALLATION
19. CONTRACTOR SHALL INFORM THE COMPANY REPRESENTATIVE TO ANY CONSTRUCTION OBSTRUCTION OR DEVIATION FROM THE SPECIFICATION AND DRAWING.
20. THE CONTRACTOR MAY CONSTRUCT THE HANDHOLE CAST IN PLACE UPON APPROVAL BY THE SEC INSPECTOR.
21. PRECAST HANDHOLE SHALL BE HANDLES AND TRANSPORTED BY THE CONTRACTOR TO ITS FINAL POSITION IN A PROFESSIONAL MANNER TO PREVENT DAMAGE SHALL BE THE RESPONSIBILITY OF THE CONTRACTOR TO REPAIR.
22. THE DUCT FORMATION SHALL BE TRANSFORMED FROM HORIZONTAL TO VERTICAL CONFIGURATION STARTING 10M FROM THE HANDHOLE WALL.
23. HANDHOLE SHALL BE USED ONLY FOR 2 DUCTS CONFIGURATION FOR 4 OR MORE DUCTS USE MANHOLE PER DRAWING TA-800096 OR TA-800097 AS NEEDED.
24. REMOVABLE HOOK LADDER TO BE PROVIDED ON END HANDHOLE WITH SPLICE AND 2 SPARE REMOVABLE HOOK LADDER FOR EACH LINES. SEE DRAWING TB-800098 DETAIL 8.



Supplier:



ENGR:	ENGR1	PROJECT:	SCALE:	SCALE
CAD:	CAD1	COMMUNICATION HANDHOLE(Dwg.TB800076) (In NON TRAFFIC AREAS)	HOR.	
REV.	DATE		VERT.	
#1			DRAWING NO.	
			SHEET NO.	1 OF 1
		LENGTH x WIDTH x HEADROOM	DATE:	
		OD : 1550 X 1550 X 1700	CHECKED BY:	
		ID : 1200 X 1200 X 1200	APPROVED BY:	
			SIGN:	

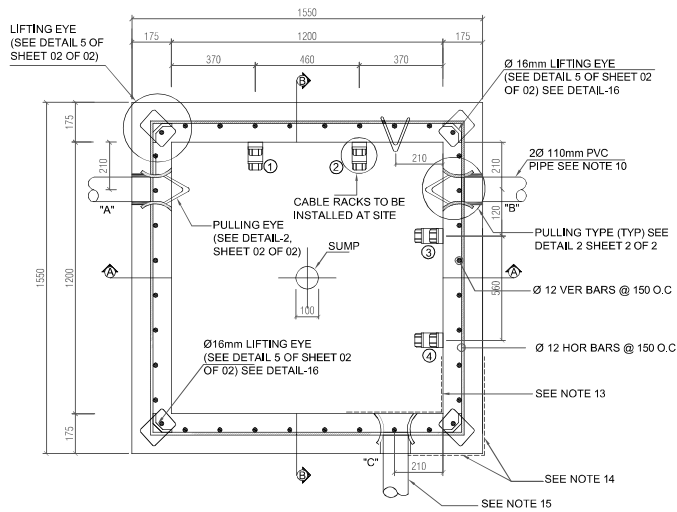

HAND HOLE DETAIL PLAN

NOTE: 1.FOR STRAIGHT RUN CONDUIT MARKED "C" AND CABLE RACK MARKED "3" 4 SHALL BE DELETED.
2.FOR CORNER HANDHOLE DELETE CONDUIT MARKED "B"

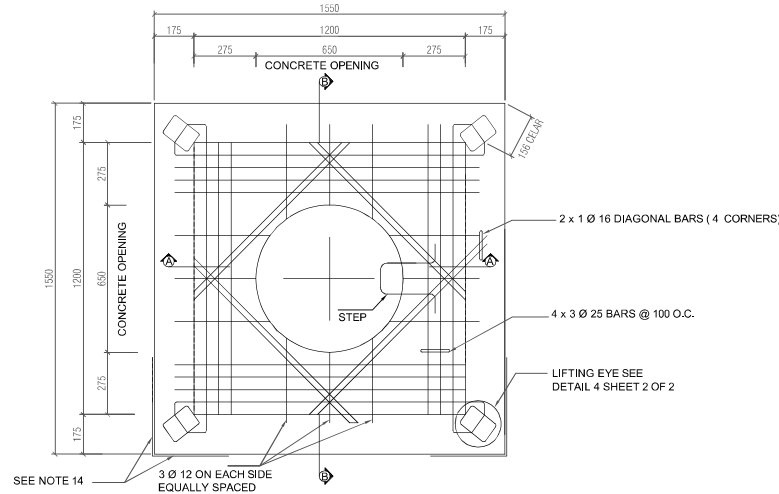

HANDHOLE ROOF SLAB REINFORCEMENT

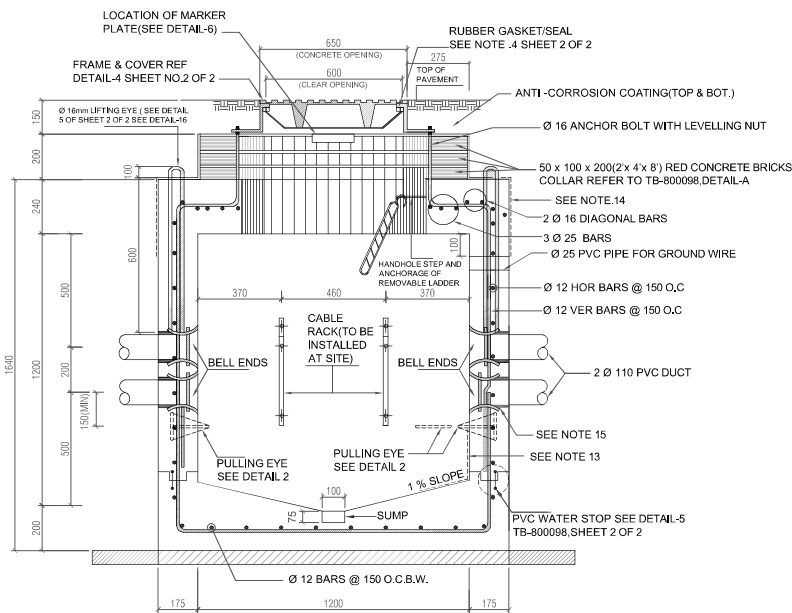

SECTION THRU-"A"

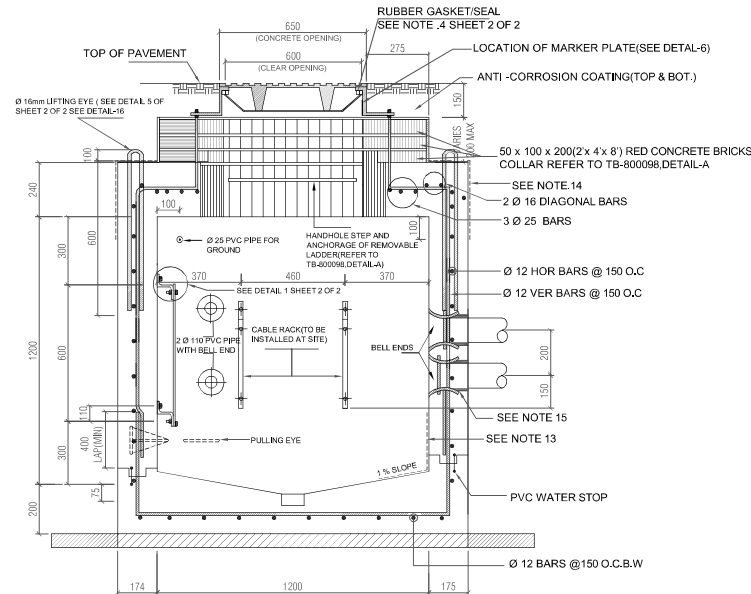

SECTION THRU-"B"

NOTES:

1. ALL DIMENSIONS ARE IN MILLIMETERS UNLESS OTHERWISE NOTED.
2. REINFORCEMENT STEEL SHALL BE DEFORMED BARS CONFORMING TO SASO SASO/2/1992. WITH A YIELD STRESS OF 420 MPa. DEFORMATIONS SHALL BE PER ASTM A615M.
3. SPLICES OF STEEL REINFORCEMENT SHALL BE IN ACCORDANCE WITH ACT 318 M.
4. MINIMUM COVER OF STEEL REINFORCEMENT SHALL SATISFY THE REQUIREMENTS OF 70-TMSS-03 AND ACT 318M
5. STEEL REINFORCEMENT AROUND THE SUMP SHALL BE BENT TO PROVIDE ADEQUATE CONCRETE COVER OVER THE REINFORCEMENT.
6. UNLESS SPECIFIED, CONCRETE TO BE USED SHALL BE CONCRETE FOR SEVERE EXPOSURE CONFORMING TO SEC MATERIALS STANDARDS SPECIFICATIONS 70-TMSS-03
7. PULLING EYES SHALL BE INSTALLED IN THE WALLS OPPOSITE EACH OTHER CABLE DUCT OPENINGS AS SHOWN IN THE DRAWING, PULLING EYES SHALL BE GALVANIZED IN ACCORDANCE WITH ASTM A123.
8. STEEL REINFORCEMENT SHALL NOT BE HEATED FOR THE PROPOSE OF FIELD BENDING.
9. ALL CABLE DUCT SHALL TERMINATING INSIDE THE HANDHOLE SHALL BE EQUIPPED WITH BELL END INSTALLED FLUSH WITH THE INTERIOR FACE OF THE WALL BOTH EMPTY & OCCUPIED CABLE DUCT SHALL BE SEALED WITH DUCT SEALING UNIT CONFORMING TO 23-TMSS-01
10. THE CABLE DUCTS SHALL BE CLASS IV STRENGTH FOR TYPE DB DIRECT BURRIED AND CLASS III FOR TYPE EB CONCRETE ENCASE CONFORMING TO SASO /14/1998 AND 23-TMSS-01
11. HANDHOLE SLAB AND WALL SHALL BE CAST MONOLITHIC CONSTRUCTION JOINTS SHALL BE PROVIDED WITH PVC WATER STOP TO ENSURE WATER TIGHTNESS OF JOINTS IF APPLICABLE.
12. PRECAST HANDHOLE SHALL BE PLACED ON LEVEL 100MM THICK LEAN CONCRETE WHICH IS PLACED OVER HAVEL COMPACTED SELECT FILL OF 200MM DEPTH, PROVIDE PLUS 300MM EXTRA DIMENSION ALL AROUND THE PRECAST HANDHOLE AND THE BASE PER CENTERING DURING INSTALLATION.
13. ALL INTERIOR SURFACES OF HANDHOLES SHALL BE COATED WITH ELASTOMERIC CEMENTITIOUS IMPERMEABLE MEMBRANE WITH MINIMUM WEIGHT FILL THICKNESS OF 1MM.
14. WATERPROOFING OF COMMUNICATION HANDHOLES SHALL BE PER DRAWING TB-800098
15. CABLE DUCTS INTERFACE WITH CONCRETE SHALL BE SEALED WITH APPROVED JOINT SEALANTS PRIOR TO WATERPROOFING
16. ALL VOIDS AROUND LIFTING EYES SHALL BE FILLED WITH NON SHRINK GROUT AFTER INSTALLATION OF HANDHOLE AT SITE.
17. GROUNDING INSTALLATION AND GROUND REINSTATEMENT TEST PER DRAWING TB-800098 AND TES-P-119.10 SHALL BE CONDUCTED RESPECTIVELY PRIOR TO BACKFILLING AND REINSTATEMENT GROUND RESISTANCE SHALL BE MAXIMUM 25 OHMS.
18. CONTRACTOR SHALL BE CLEAN THE DUCTS AND HANDHOLE TO THE SATISFACTION OF SEC INSPECTOR AFTER INSTALLATION
19. CONTRACTOR SHALL INFORM THE COMPANY REPRESENTATIVE TO ANY CONSTRUCTION OBSTRUCTION OR DEVIATION FROM THE SPECIFICATION AND DRAWING.
20. THE CONTRACTOR MAY CONSTRUCT THE HANDHOLE CAST IN PLACE UPON APPROVAL BY THE SEC INSPECTOR.
21. PRECAST HANDHOLE SHALL BE HANDLES AND TRANSPORTED BY THE CONTRACTOR TO ITS FINAL POSITION IN A PROFESSIONAL MANNER TO PREVENT DAMAGE SHALL BE THE RESPONSIBILITY OF THE CONTRACTOR TO REPAIR.
22. THE DUCT FORMATION SHALL BE TRANSFORMED FROM HORIZONTAL TO VERTICAL CONFIGURATION USING 10M FROM THE HANDHOLE WALL.
23. HANDHOLE SHALL BE USED ONLY FOR 2 DUCTS CONFIGURATION FOR 4 OR MORE DUCTS USE MANHOLE PER DRAWING TA-800096 OR TA-800097 AS NEEDED.
24. REMOVABLE HOOK LADDER TO BE PROVIDED ON END HANDHOLE WITH SPLICE AND 2 SPARE REMOVABLE HOOK LADDER FOR EACH LINES. SEE DRAWING TB-800098 DETAIL 8.



Supplier:



ENGR.:	ENGR1	PROJECT:	COMMUNICATION HANDHOLE (Dwg. TB0077) (in TRAFFIC AREAS)	SCALE:	SCALE
CAD:	CAD1			HOR.	
REV.	DATE	SIGN		VERT.	
#1				DRAWING NO.	
				SHEET NO.	1 OF 1
				DATE:	
				CHECKED BY:	
				APPROVED BY:	
				SIGN:	

LENGTH x WIDTH x HEADROOM
OD : 1550 x 1550 x 1640
ID : 1200 x 1200 x 1200

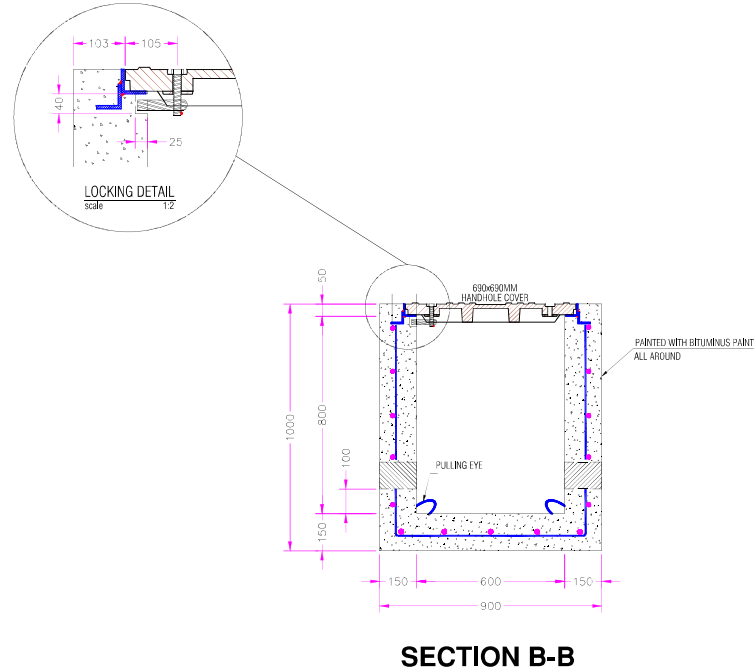
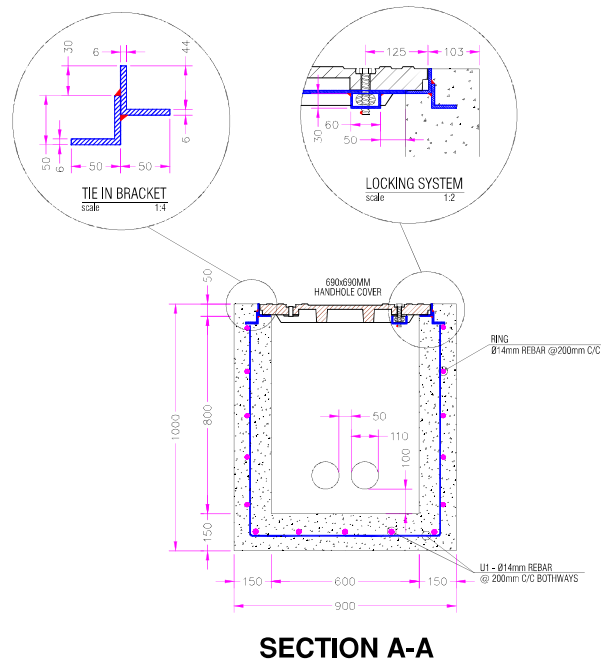
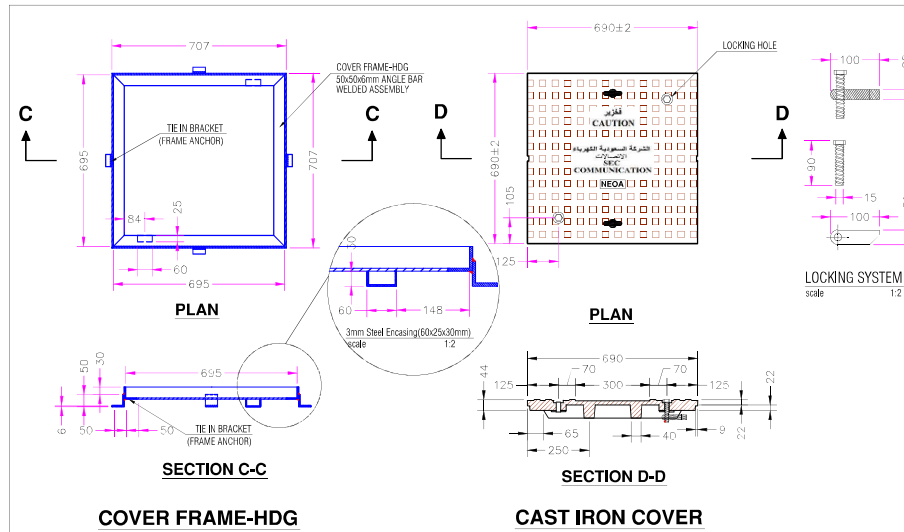
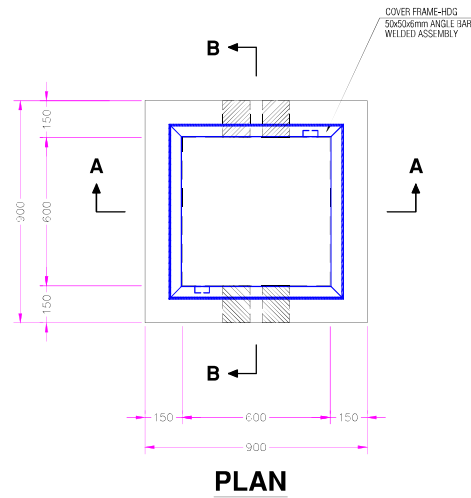

NO.	ACCESSORIES CHECKLIST	QUANTITY
1	HANDHOLE COVER-HD40(690mmx690mm)	1 EA
2	HANDHOLE FRAME (50mmx50mmx6)	1 EA
3	PULLING EYE	2 EA
4	EXPANSION BOLT	2 EA
5	LIFTING BAR	2 EA

NOTES:

1. ALL DIMENSIONS ARE IN MILLIMETERS UNLESS OTHERWISE INDICATED.
2. CONCRETE CYLINDER COMPRESSIVE STRENGTH SHALL BE MINIMUM OF CLASS C30 CONCRETE AT 28 DAYS.
3. CEMENT SHALL BE SULFATE RESISTANT, TYPE V CONFORMING TO ASTM C150.
4. STEEL REINFORCEMENTS SHALL CONFORM TO ASTM A615, DEFORMED BARS GRADE 60 WITH MINIMUM YIELD STRENGTH OF 420MPa.
5. WALL EXPOSED TO EARTH SHALL BE COATED WITH APPROVED BITUMINOUS MATERIAL.
6. H.D CAST IRON COVER 40 TON LOADING CAPACITY 690 X 690



SUPPLIER:



ENGR.:	ENGR1	PROJECT:	SCALE:
CAD:	CAD1		VERT.
REV. #1	DATE: 23/04/17	SIGN:	TITLE: PULLING BOX DETAIL
			LENGTH x WIDTH x HEADROOM
			OD : 900 X 900 X 1000
			ID : 600 X 600 X 800
			DRAWING NO.
			SHEET NO. 1 OF 1
			DATE:
			CHECKED BY:
			APPROVED BY:
			SIGN:

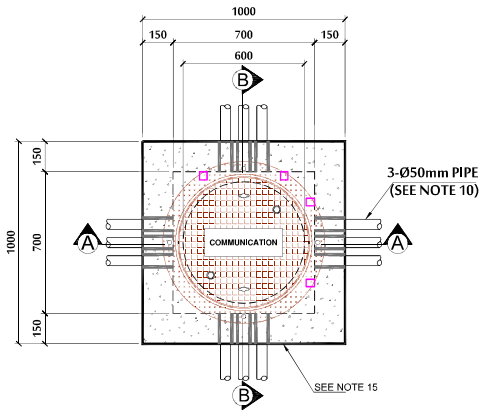

PLAN VIEW

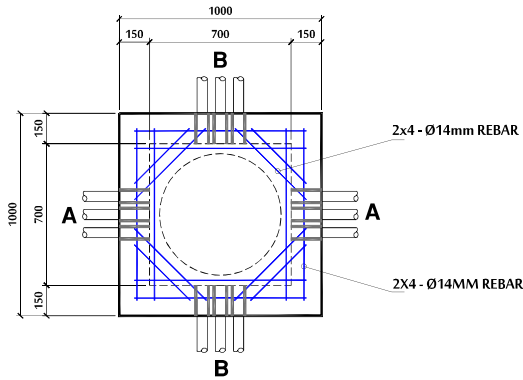

ROOF SLAB REINFORCEMENT

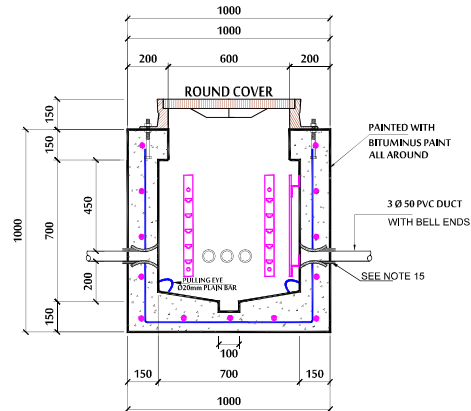

SECTION A-A

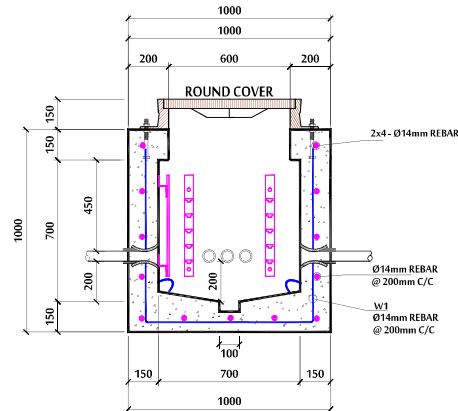

SECTION B-B

13. ALL INTERIOR SURFACES OF HANDHOLES SHALL BE COATED WITH ELASTOMERIC CEMENTITIOUS IMPERMEABLE MEMBRANE WITH MINIMUM WEIGHT FILL THICKNESS OF 1MM.
14. WATERPROOFING OF COMMUNICATION HANDHOLES SHALL BE PER DRAWING TB-800098
15. CABLE DUCTS INTERFACE WITH CONCRETE SHALL BE SEALED WITH APPROVED JOINT SEALANTS PRIOR TO WATERPROOFING
16. ALL VOIDS AROUND LIFTING EYES SHALL BE FILLED WITH NON SHRINK GROUT AFTER INSTALLATION OF HANDHOLE AT SITE.
17. GROUNDING INSTALLATION AND GROUND REINSTATE TEST PER DRAWING TB-800098 AND TES-P-119.10 SHALL BE CONDUCTED RESPECTIVELY PRIOR TO BACKFILLING AND REINSTATEMENT GROUND RESISTANCE SHALL BE MAXIMUM 25 OHMS.
18. CONTRACTOR SHALL BE CLEAN THE DUCTS AND HANDHOLE TO THE SATISFACTION OF SEC INSPECTOR AFTER INSTALLATION
19. CONTRACTOR SHALL INFORM THE COMPANY REPRESENTATIVE TO ANY CONSTRUCTION OBSTRUCTION OR DEVIATION FROM THE SPECIFICATION AND DRAWING.
20. THE CONTRACTOR MAY CONSTRUCT THE HANDHOLE CAST IN PLACE UPON APPROVAL BY THE SEC INSPECTOR.
21. PRECAST HANDHOLE SHALL BE HANDLES AND TRANSPORTED BY THE CONTRACTOR TO ITS FINAL POSITION IN A PROFESSIONAL MANNER TO PREVENT DAMAGE SHALL BE THE RESPONSIBILITY OF THE CONTRACTOR TO REPAIR.
22. THE DUCT FORMATION SHALL BE TRANSFORMED FROM HORIZONTAL TO VERTICAL CONFIGURATION STARTING 10M FROM THE HANDHOLE WALL.
23. HANDHOLE SHALL BE USED ONLY FOR 2 DUCTS CONFIGURATION FOR 4 OR MORE DUCTS USE MANHOLE PER DRAWING TA-800096 OR TA-800097 AS NEEDED.
24. REMOVABLE HOOK LADDER TO BE PROVIDED ON END HANDHOLE WITH SPLICE AND 2 SPARE REMOVABLE HOOK LADDER FOR EACH LINES. SEE DRAWING TB-800098 DETAIL 8.

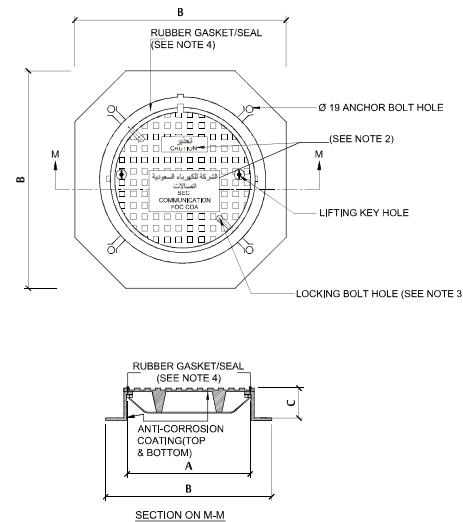

CLEAR OPENING A(mm)	OVER BASE B(mm)	DEPTH C(mm)	WEIGHT (kg)	LOADING (TONS)
600 dia	830 sq	150	200	40

HANDHOLE FRAME AND COVER

DETAIL-4

NO.	ACCESSORIES CHECKLIST	QUANTITY
1	CABLE BRACKET SUPPORT(500mm)	4 EA
2	CABLE BRACKET(250mm)	8 EA
3	HEAVY DUTY CAST IRON FRAME & COVER (HD-40)	1 EA
4	PULLING EYE(Ø20MM PLAIN BAR)	2 EA
5	EXPANSION BOLT(Ø12mm X120mm LONG)	8 EA
7	LADDER SUPPORT (Ø15mm PLAIN BAR)	1 EA
8	LIFTING BAR(Ø14mm)	2 EA

NOTES:

1. ALL DIMENSIONS ARE IN MILLIMETERS UNLESS OTHERWISE NOTED.
2. REINFORCEMENT STEEL SHALL BE DEFORMED BARS CONFORMING TO SASO SASO//2/1992. WITH A YIELD STRESS OF 420 MPa. DEFORMATIONS SHALL BE PER ASTM A615M.
3. SPLICES OF STEEL REINFORCEMENT SHALL BE IN ACCORDANCE WITH ACT 318 M.
4. MINIMUM COVER OF STEEL REINFORCEMENT SHALL SATISFY THE REQUIREMENTS OF 70-TMSS-03 AND ACT 318M
5. STEEL REINFORCEMENT AROUND THE SUMP SHALL BE BENT TO PROVIDE ADEQUATE CONCRETE COVER OVER THE REINFORCEMENT.
6. UNLESS SPECIFIED, CONCRETE TO BE USED SHALL BE CONCRETE FOR SEVERE EXPOSURE CONFIRMING TO SEC MATERIALS STANDARDS SPECIFICATIONS 70-TMSS-03
7. PULLING EYES SHALL BE INSTALLED IN THE WALLS OPPOSITE EACH OTHER CABLE DUCT OPENINGS AS SHOWN IN THE DRAWING, PULLING EYES SHALL BE GALVANIZED IN ACCORDANCE WITH ASTM A313.
8. STEEL REINFORCEMENT SHALL NOT BE HEATED FOR THE PROPOSE OF FIELD BENDING.
9. ALL CABLE DUCT SHALL TERMINATING INSIDE THE HANDHOLE SHALL BE EQUIPPED WITH BELL END INSTALLED FLUSHED WITH THE INTERIOR FACE OF THE WALL BOTH EMPTY & OCCUPIED CABLE DUCT SHALL BE SEALED WITH DUCT SEALING UNIT CONFORMING TO 23-TMSS-01
10. THE CABLE DUCTS SHALL BE CLASS IV STRENGTH FOR TYPE DB DIRECT BURRIED AND CLASS III FOR TYPE EB CONCRETE ENCASE CONFORMING TO SASO /14/1998 AND 23-TMSS-01
11. HANDHOLE SLAB AND WALL SHALL BE CAST MONOLITHIC CONSTRUCTION JOINTS SHALL BE PROVIDED WITH PVC WATER STOP TO ENSURE WATER TIGHTNESS OF JOINTS IF APPLICABLE.
12. PRECAST HANDHOLE SHALL BE PLACED ON LEVEL 100MM THICK LEAN CONCRETE WHICH IS PLACED OVER HAVEL COMPACTED SELECT FILL OF 200MM DEPTH, PROVIDE PLUS 300MM EXTRA DIMENSION ALL AROUND THE PRECAST HANDHOLE AND THE BASE PER CENTERING DURING INSTALLATION.



SUPPLIER:



ENGR:	PROJECT:	SCALE:
ENGR1		SCALE
CAD:		HDR.
CAD1		VERT.
REV. DATE SIGN	COMMUNICATION HANDHOLE (ROUND COVER)	DRAWING NO.
#1 15/05/18		SHEET NO. 1 OF 1
	LENGTH x WIDTH x HEADROOM OD : 1000 X 1000 X 1000 ID : 700 X 700 X 700	DATE:
		CHECKED BY:
		APPROVED BY:
		FOR:

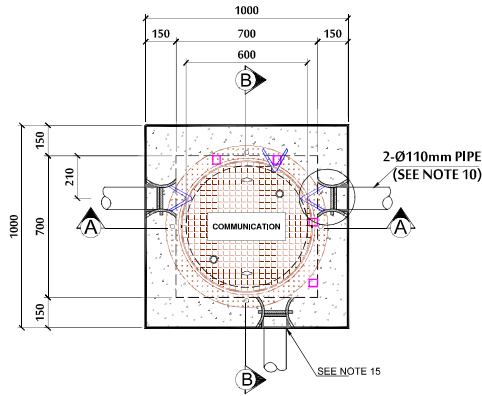

PLAN VIEW

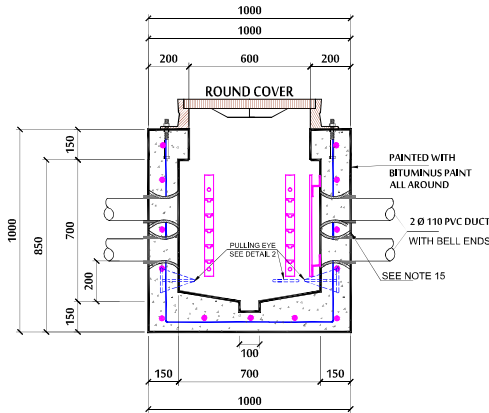

SECTION A-A

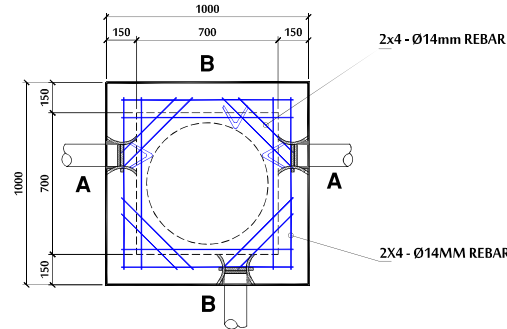

ROOF SLAB REINFORCEMENT

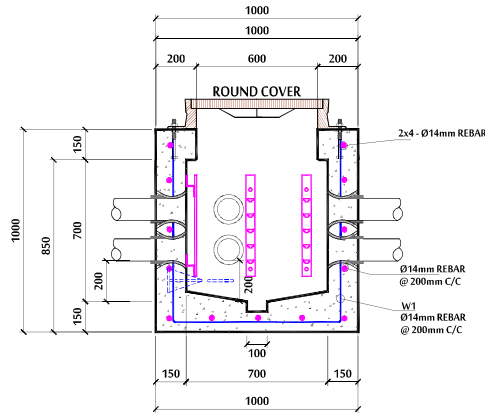

SECTION B-B

13. ALL INTERIOR SURFACES OF HANDHOLES SHALL BE COATED WITH ELASTOMERIC CEMENTITIOUS IMPERMEABLE MEMBRANE WITH MINIMUM WEIGHT FILL THICKNESS OF 1MM.
14. WATERPROOFING OF COMMUNICATION HANDHOLES SHALL BE PER DRAWING TB-800098
15. CABLE DUCTS INTERFACE WITH CONCRETE SHALL BE SEALED WITH APPROVED JOINT SEALANTS PRIOR TO WATERPROOFING
16. ALL VOIDS AROUND LIFTING EYES SHALL BE FILLED WITH NON SHRINK GROUT AFTER INSTALLATION OF HANDHOLE AT SITE.
17. GROUNDING INSTALLATION AND GROUND REINSTATE TEST PER DRAWING TB-800098 AND TES-P-119.10 SHALL BE CONDUCTED RESPECTIVELY PRIOR TO BACKFILLING AND REINSTATEMENT GROUND RESISTANCE SHALL BE MAXIMUM 25 OHMS.
18. CONTRACTOR SHALL BE CLEAN THE DUCTS AND HANDHOLE TO THE SATISFACTION OF SEC INSPECTOR AFTER INSTALLATION
19. CONTRACTOR SHALL INFORM THE COMPANY REPRESENTATIVE TO ANY CONSTRUCTION OBSTRUCTION OR DEVIATION FROM THE SPECIFICATION AND DRAWING.
20. THE CONTRACTOR MAY CONSTRUCT THE HANDHOLE CAST IN PLACE UPON APPROVAL BY THE SEC INSPECTOR.
21. PRECAST HANDHOLE SHALL BE HANDLES AND TRANSPORTED BY THE CONTRACTOR TO ITS FINAL POSITION IN A PROFESSIONAL MANNER TO PREVENT DAMAGE SHALL BE THE RESPONSIBILITY OF THE CONTRACTOR TO REPAIR.
22. THE DUCT FORMATION SHALL BE TRANSFORMED FROM HORIZONTAL TO VERTICAL CONFIGURATION STARTING 10M FROM THE HANDHOLE WALL.
23. HANDHOLE SHALL BE USED ONLY FOR 2 DUCTS CONFIGURATION FOR 4 OR MORE DUCTS USE MANHOLE PER DRAWING TA-800096 OR TA-800097 AS NEEDED.
24. REMOVABLE HOOK LADDER TO BE PROVIDED ON END HANDHOLE WITH SPLICE AND 2 SPARE REMOVABLE HOOK LADDER FOR EACH LINES. SEE DRAWING TB-800098 DETAIL 8.

NO.	ACCESSORIES CHECKLIST	QUANTITY
1	CABLE BRACKET SUPPORT(500mm)	3 EA
2	CABLE BRACKET(250mm)	6 EA
3	HEAVY DUTY CAST IRON FRAME & COVER (HD-40)	1 EA
4	PULLING EYE(Ø20MM PLAIN BAR)	3 EA
5	EXPANSION BOLT(Ø12mm X120mm LONG)	6 EA
7	LIFTING BAR(Ø14mm)	2 EA

NOTES:

1. ALL DIMENSIONS ARE IN MILLIMETERS UNLESS OTHERWISE NOTED.
2. REINFORCEMENT STEEL SHALL BE DEFORMED BARS CONFORMING TO SASO SASO//2/1992. WITH A YIELD STRESS OF 420 MPa. DEFORMATIONS SHALL BE PER ASTM A615M.
3. SPLICES OF STEEL REINFORCEMENT SHALL BE IN ACCORDANCE WITH ACT 318 M.
4. MINIMUM COVER OF STEEL REINFORCEMENT SHALL SATISFY THE REQUIREMENTS OF 70-TMSS-03 AND ACT 318M
5. STEEL REINFORCEMENT AROUND THE SUMP SHALL BE BENT TO PROVIDE ADEQUATE CONCRETE COVER OVER THE REINFORCEMENT.
6. UNLESS SPECIFIED, CONCRETE TO BE USED SHALL BE CONCRETE FOR SEVERE EXPOSURE CONFIRMING TO SEC MATERIALS STANDARDS SPECIFICATIONS 70-TMSS-03
7. PULLING EYES SHALL BE INSTALLED IN THE WALLS OPPOSITE EACH OTHER CABLE DUCT OPENINGS AS SHOWN IN THE DRAWING, PULLING EYES SHALL BE GALVANIZED IN ACCORDANCE WITH ASTM A313.
8. STEEL REINFORCEMENT SHALL NOT BE HEATED FOR THE PROPOSE OF FIELD BENDING.
9. ALL CABLE DUCT SHALL TERMINATING INSIDE THE HANDHOLE SHALL BE EQUIPPED WITH BELL END INSTALLED FLUSHED WITH THE INTERIOR FACE OF THE WALL BOTH EMPTY & OCCUPIED CABLE DUCT SHALL BE SEALED WITH DUCT SEALING UNIT CONFORMING TO 23-TMSS-01
10. THE CABLE DUCTS SHALL BE CLASS IV STRENGTH FOR TYPE DB DIRECT BURRIED AND CLASS III FOR TYPE EB CONCRETE ENCASE CONFORMING TO SASO /14/1998 AND 23-TMSS-01
11. HANDHOLE SLAB AND WALL SHALL BE CAST MONOLITHIC CONSTRUCTION JOINTS SHALL BE PROVIDED WITH PVC WATER STOP TO ENSURE WATER TIGHTNESS OF JOINTS IF APPLICABLE.
12. PRECAST HANDHOLE SHALL BE PLACED ON LEVEL 100MM THICK LEAN CONCRETE WHICH IS PLACED OVER HAVEL COMPACTED SELECT FILL OF 200MM DEPTH, PROVIDE PLUS 300MM EXTRA DIMENSION ALL AROUND THE PRECAST HANDHOLE AND THE BASE PER CENTERING DURING INSTALLATION.

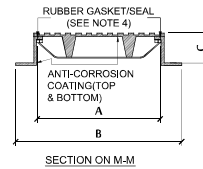
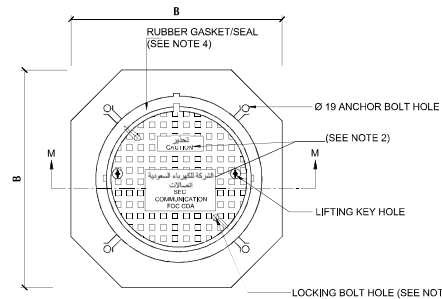
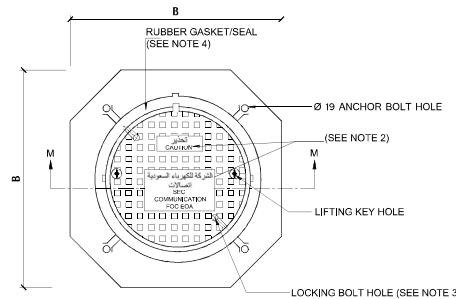

CLEAR OPENING A(mm)	OVER BASE B(mm)	DEPTH C(mm)	WEIGHT (kg)	LOADING (TONS)
600 dia	830 sq	150	200	40

HANDHOLE FRAME AND COVER

DETAIL-4



SUPPLIER:



ENGR:	ENGR1	PROJECT:	SCALE:
CAD:	CAD1	COMMUNICATION HANDHOLE (ROUND COVER)	SCALE
REV:	DATE		DATE
#1	15/05/18	15/05/18	1 OF 1
		LENGTH x WIDTH x HEADROOM	CHECKED BY:
		OD : 1000 X 1000 X 1000	APPROVED BY:
		ID : 700 X 700 X 700	DATE:

DORAT AL TAL PRECAST CONCRETE FACTORY

ISO 9001:2015; OHSAS 18001:2007 Certified Company

Dorat AL-Tal Co.
For Contracting

TEL NO. 011 – 4660408

FAX NO. 011 – 4661016

Email : dorat@dorataltal.com

sales2@dorataltal.com

PO.BOX 10700, RIYADH 11443

KINGDOM OF SAUDI ARABIA



شركة درة التل
للمقاولات

رقم هاتف 011 - 4660408

رقم فاكس 011 - 4661016

Email : dorat@dorataltal.com

sales2@dorataltal.com

ص. ب. 10700 , الرياض 11443

المملكة العربية السعودية

