



PRODUCT CATALOGUE



WE DELIVER ON OUR PROMISES

UNRIVALLED QUALITY INNOVATION, CUSTOMER SERVICE

Frontier Safety Ltd UK is one of the Britain's largest and the most respected manufacturers of Innovative products for the demanding and diverse fire pumps.

FRONTIER SAFETY LTD

Providing outstanding commercial, industrial, and residential fire protection services in United Kingdom (UK), United Arab Emirates (UAE) and globally.

Specializing in fire pump design, fabrication, installation, and support as well as fire alarm designs, installation and support in both the commercial and residential markets, Frontier Safety Limited recognizes our success stems from leaders who are knowledgeable, respected, and trustworthy, working with employees who exemplify pride, initiative, and personal conviction.

Through these high ideals, we lead as an entity with genuine concern for our employees, making them top priority. The resulting loyalty and sense of honour elevates a greatness that is measured by the achievements of our employees. Frontier Safety Limited sets itself apart from other fire protection & safety contractors through our strong relationships with customers and employees, innovation, and time-tested quality work.

Our goal is to provide better customer services than any other contractor. We accomplish this through developing personal relationship with our customers and ensuring that they are completely satisfied with our work.



FRONTIER
SAFETY LTD UK





FIRE ALARM SYSTEM



FIRE ALARM SYSTEM Schematic Diagram

ADDRESSABLE FIRE ALARM SYSTEM



CONVENTIONAL FIRE ALARM SYSTEM

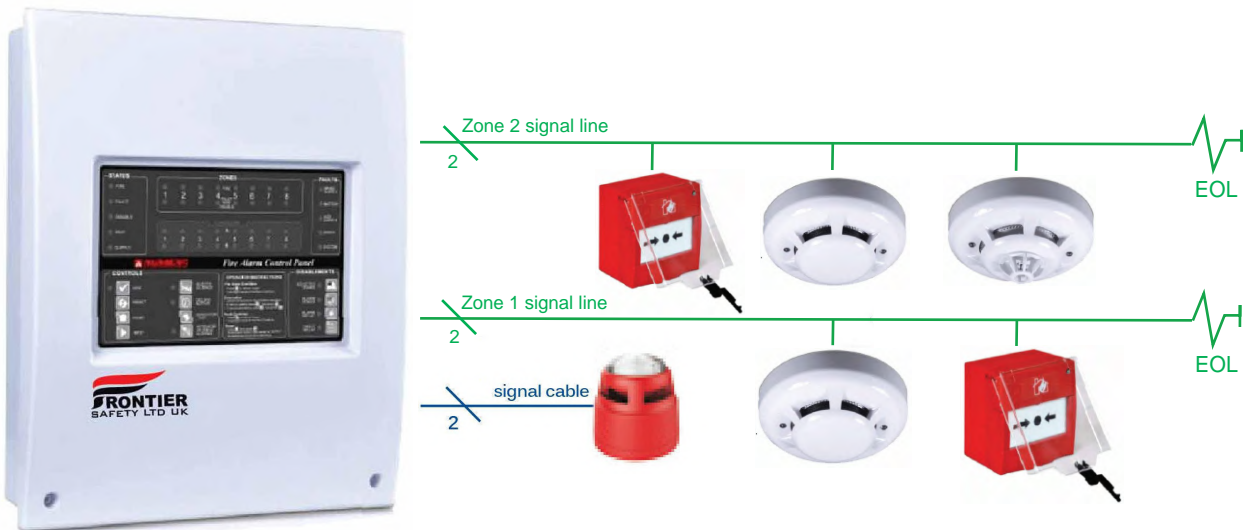

FIRE ALARM CONTROL PANEL

Frontier addressable fire alarm control panel designed to comply with the latest versions of EN 54 parts 2&4 with qualities of simple installation, operation and easy maintenance. The wide range of configurations include



ADDRESSABLE FIRE ALARM SYSTEM

FRN 3002- ADDRESSABLE FIRE ALARM CONTROL PANEL

PRODUCT FEATURES:

- Up to 324 addresses for one loop.
- 4.3" color screen LCD, resolution of 480x272.
- Zone indication and control panel for 32 zones give a quick indication of the location of an alarm.
- Record capacity of 1000 historical events with date/time stamp.
- Integral power supply and battery.
- Integral printer.
- A standalone programmable conventional sounder circuit output.
- Flexible and intuitive cause and effect programming on front of panel.
- Output module manual start/stop facilitates the commissioning and operating.
- It supports the detector/module testing individually.
- USB port makes the load and save of configuration data or historical data convenient for system commissioning and maintenance.
- Hierarchy management with three access levels.
- Anti-tamper protection by a key lock.
- Networkable: CAN bus for interconnection of up to 20 FACPs and Ethernet for up to 255 FACPs.



TECHNICAL PARAMETERS:

Main power supply	220V/230VAC±15%. 47~63Hz. Max current 0.8A
Mains fuse	T3.15AL250V
Max. battery capacity and type	2x12V/17Ah VRLA
Max. charging current	1.2A
Max. internal resistance of battery	1Ω
Fire alarm output (+, -)	Output voltage 18.5VDC~27.5VDC Max. output current 0.5A End of line resistor 4.7KΩ
F.P.E. output (+,-)	Output voltage 18.5VDC~27.5VDC Max. output current 0.5A End of line resistor 4.7KΩ
Sounder circuit output (+,-)	Output voltage 18.5VDC~27.5VDC Max. output current 0.5A End of line resistor 4.7KΩ
Fault output (NC, COM, NO)	Contact capacity 30VDC@2A, 125VAC@0.5A
24V (+, -)	Output voltage 18.5VDC~27.5VDC Max. output current 0.6A
Class Change	Programmable input terminal. Shorting this terminal can enable Sounder Circuit Output (S.C. Out).
Loop Out (+, -)	Polarized signal cable from the FACP connects to 324 addressable devices
Loop In (+, -)	Polarized signal cable returns to the FACP
Temperature	-10°C~ +55°C
Humidity	≤95% (40°C±2°C, no condensation)
Dimension (HxWxD)	565x430x170mm

ADDRESSABLE FIRE ALARM SYSTEM

POINT-TYPE PHOTOELECTRIC SMOKE DETECTOR (FRN 30)



Product Features:

- It supports soft addressing and the address rewriting via coder in situ.
- Within a single-chip microcomputer, it can process the sampling data in real-time, save the latest 144 historical data and realize a curve tracing for the field situation.
- It supports temperature, humidity and dust accumulation drift compensation and sensor fault inspection (fault reporting to fire alarm control panel).
- Non-polarity, two-wire bus connection that ensures convenient installation and maintenance.
- Designed with an upper cover and a lower cover and installed on a detector base, it can be installed, commissioned and maintained conveniently.
- Built-in remote indicator output terminal, the output signal drives remote indicator light when fire alarm.
- Comply with EN54-7.

POINT TYPE HEAT DETECTOR (FRN 20)



Product Features:

- It supports soft addressing and the address rewriting via coder in situ.
- Within a single-chip microcomputer, it can collect real-time data and then process it to realize a curve tracing for the field situation.
- It supports temperature compensation and a sensor fault detection (fault reporting to the fire alarm control panel).
- Non-polarity, two-wire bus wiring that ensures convenient installation and maintenance.
- Designed with an upper cover and a lower cover and installed on a detector base, so it can be installed, commissioned and maintained conveniently and do not distinguish the connection line.
- Built-in remote indicator output terminal, the output signal drives remote indicator light when fire alarm.
- Comply with EN54-5 .

MANUAL CALL POINT (FRN 60)



Product Features:

- Semi-flush or surface mount.
- Lever reusable (non-glass break).
- LED indicator.
- Support non-polarity, complete soft addressing in situ.
- Designed with passive output contacts to control other external equipment directly via an intermediate relay.
- Comply with EN54-11.



ADDRESSABLE FIRE ALARM SYSTEM

ADDRESSABLE SOUNDER VISUAL INDICATOR (FRN 92)



Product Features:

- Comply with EN54-3 and EN54-23.
- Designed with an upper cover and a lower cover and installed on a detector base, so it can be installed, commissioned and maintained conveniently.
- Suitable for wall and ceiling-mount installation.
- Providing 16 alarm tones.



I/O MODULE (FRN 56)



Product Features:

- Semi-flush or surface mount.
- Lever reusable (non-glass break).
- LED indicator.
- Full soft addressing and rewriting through CODER-9001 encoder in site.
- Comply with EN54-18.



SHORT CIRCUIT ISOLATOR (FRN 57)



Product Features:

- In the event of a short circuit it isolates faulty parts of the loop.
- Automatically resetting once the fault has been cleared.
- LED lights indicate status.
- Comply with EN54-17.

CONVENTIONAL FIRE ALARM SYSTEM



FRNC 4001 - CONVENTIONAL FIRE ALARM CONTROL PANEL (2,4,8 ZONE)

- 2, 4 or 8 detection zones.
- Upto 32 devices per alarm zone circuit
- Manual activation of audio visual alarm devices.
- Supervised auxiliary DC 24V output
- 2 Independently programmable non addressable AV alarm output circuit.
- 2 programmable fire alarm relay output
- Fault relay output 3 voltage free inputs for remote reset, evacuation start/ stop, and Day/ night mode.
- Supports upto 7 repeater panels.



CONVENTIONAL SMOKE DETECTORS - (FRNSC)

- Advanced algorithms provide analogue detection discrimination.
- Surface mount device circuit board design.
- High immunity against unwanted alarms.
- Stable smoke sensing chamber. No adjustment or replacement is required.
- 4 wire models available with auto reset
- 2 wire & 4 wire models available with remote LED output
- Sleek low profile housing design
- Dual LED for 360 visibility



CONVENTIONAL FIRE ALARM SYSTEM



CONVENTIONAL HEAT DETECTORS - (FRNHC)

- Durable heat sensor
- Analogue detection discrimination.
- Dual LED for 360 visibility
- 2 wire & 4 wire models available with remote LED output
- 4 wire models available with auto reset



CONVENTIONAL MANUAL CALL POINT - (FRNMCP)

- Pressure activated displacement element provide a safe user experience
- Integral indicator to show polling and alarm activation.
- Resettable with simple key operation.
- Suitable for indoor use
- Monitors for quiescent alarm & fault conditions.



CONVENTIONAL SOUNDER (FRN 91C)

- Operates when the supply voltage is connected to the devices.
- Complete with relay out put and indicating equipment or from an output module connected to addressable alarm circuit wiring
- DC 24V operation
- Loud sound output of 95 dB at 1m
- Zero current load in quiescent condition





WIRELESS SMOKE DETECTOR



205 DC SMOKE ALARM

Long Life Smoke Alarm for Residential Applications

EN 14604, VDS 3131, CE



205 DC Smoke Alarm



DESCRIPTION

205 DC smoke alarms Would battery powered Smoke detention and alarm functions within a single unit.

Advanced electronics in conjunction with a photoelectric smoke Sensing chanter provide early detection of fire and high immunity against unwanted alarms.

205 DC smoke alarms are powered by a long-life Lithium-ion battery and do not require a mains supply. Models with either user-replaceable and non-replaceable batteries are available.

Interconnectable 205 DC smoke alarms use a wireless transmission path. Configuration into a dosed group ensures that other units within radio signal range are not affected by a test or fire alarm occurring within the configured group.

The 205 DC smoke alarm is suitable for general residential applications, and provides home owners and installers with an easy-to-install long-life solution for life safety and property protection applications.

205 DC SMOKE ALARM

Long Life Smoke Alarm for Residential Applications

FEATURES

- Photoelectric smoke sensing chamber technology
- Loud 85 de sounder to alert occupants
- Integrated indicator provides visual indication of an alarm condition
- Test and Hush features in a single button
- Test and Hush visual indicator
- Test button verifies battery and alarm operation
- Hush function temporarily silences unwanted alarms
- Smoke chamber fault audible and visual indication
- Hush function temporarily silences smoke chamber fault indication
- Low battery audible and visual warning indication
- Hush function temporarily silences low battery audible indication
- Interconnectable smoke alarms configurable into a closed group
- No limit for interconnectable units using the wireless transmission path
- Up to 10 years operation under normal conditions
- User-replaceable battery and non-replaceable battery models available
- Surface-mount device (SMD) circuit board design
- Attractive housing design, available with alternative top-cover styles
- Easy installation
- Low maintenance





CENTRAL MONITORING SYSTEM

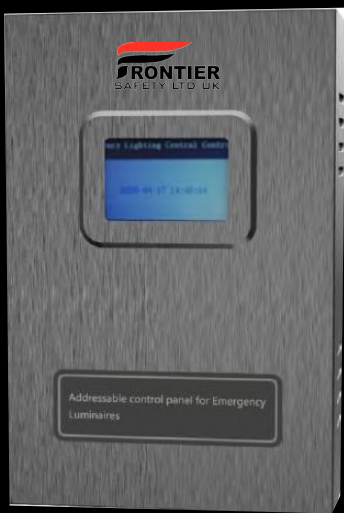

PRODUCT DATA SHEET

Central Monitoring Emergency / Exit light system

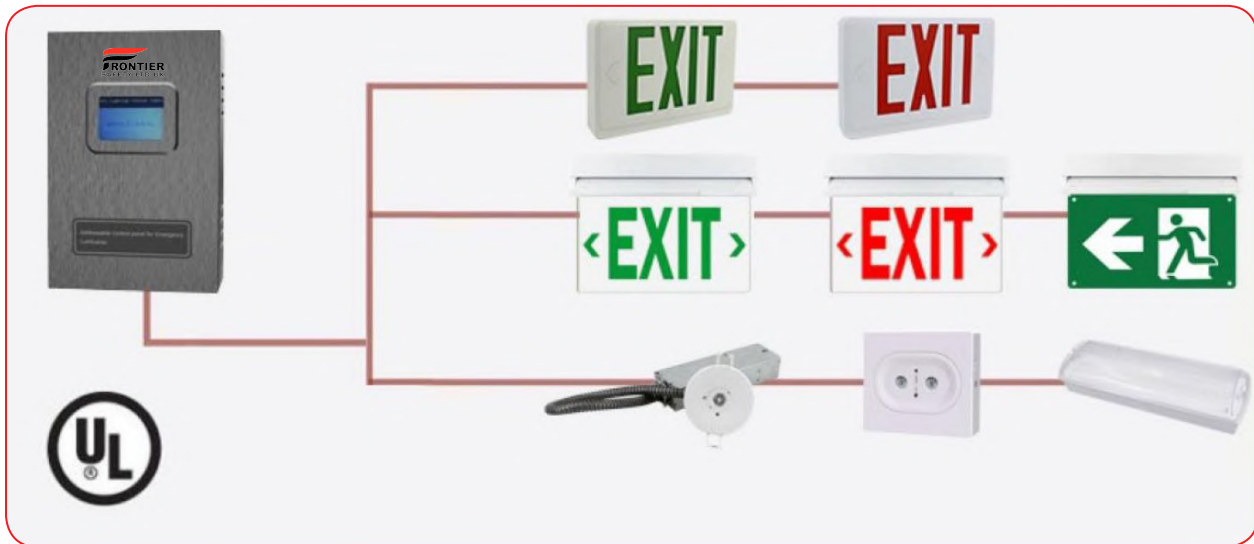

SYSTEM INTRODUCTION

The system adopts one core (two-wire), using the power supply wire for digital communication at same time, it is cost saving and easy to install. Each control panel support up to 255 emergency fixture, with a maximum distance of 1000 meters.



PRODUCT DATA SHEET

Emergency luminaire system

CENTRAL MONITORING PANEL

FRN-350-DC36U

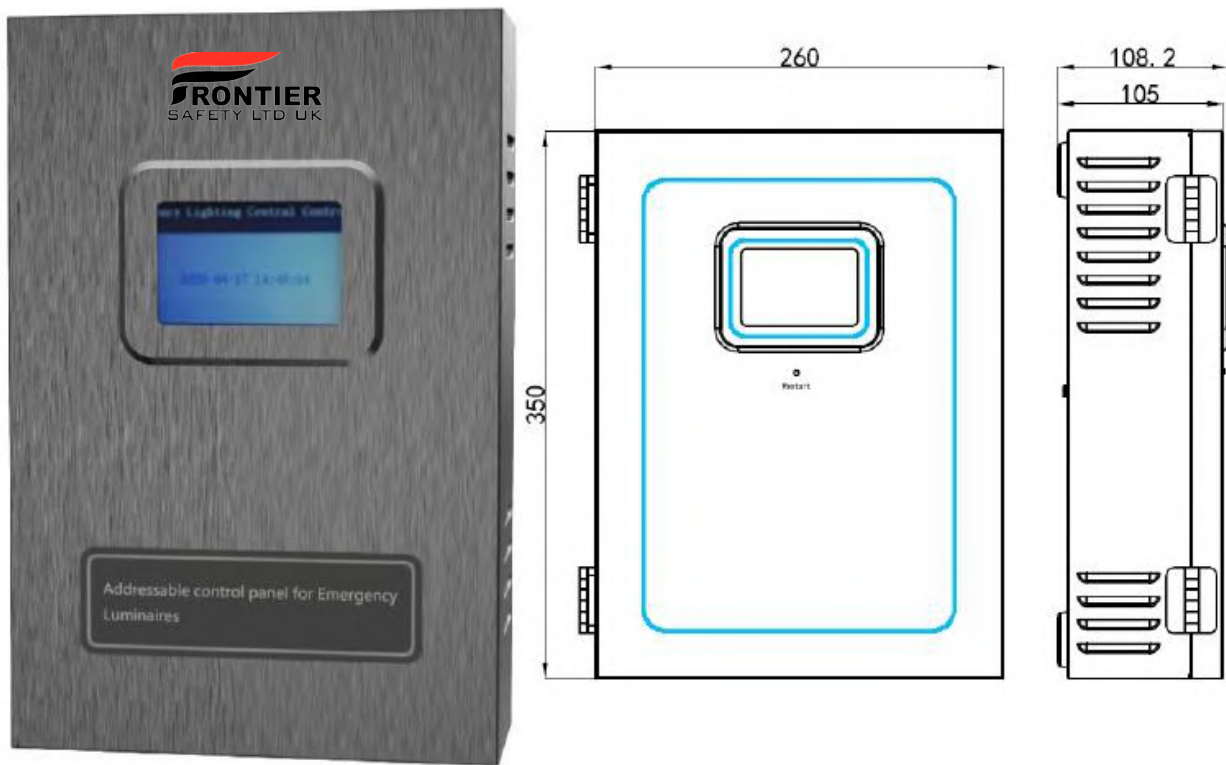

SPECIFICATION

- Input Voltage : AC 100.120V/ 200.240V
- Output voltage : DC34.5V
- IP Level : IP20
- Operation Temp : 0.40°C
- Output current : Max 8A
- Output power : Maximum 276W
- Communication distance : Up to 1000 met
- Carrying Capacity : Maximum 255 device:
- No. of Lines : 2 lines
- Certificate : UL

PRODUCT DATA SHEET

ADDRESSABLE SURFACE / RECESSED MOUNTED EMERGENCY LIGHT FRN-Z2745U

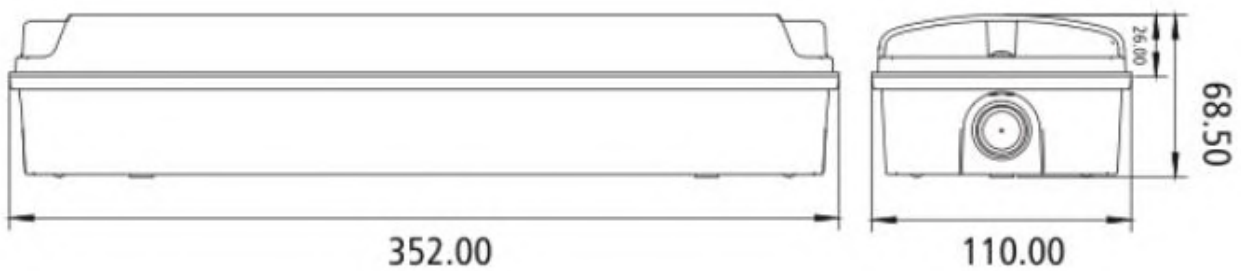

SPECIFICATION

- Mounting Method : Surface/Recessed
- Input Voltage : DC36V(DC15-40V)
- Light Source : SMD2835x27pcs
- CRI>80
- Lumen Output : 3001m
- IP Level : IP65
- Operation Model : Maintained/Non-Maintained
- Battery : LiFepo4 3.2V 3600mAh
- Battery Charge Time : 24H
- Emergency Time : 3H
- Recessed Kit (Optional)
- Certificate : UL



PRODUCT DATA SHEET

ADDRESSABLE HANGING EXIT LIGHT

FRN-B2308U

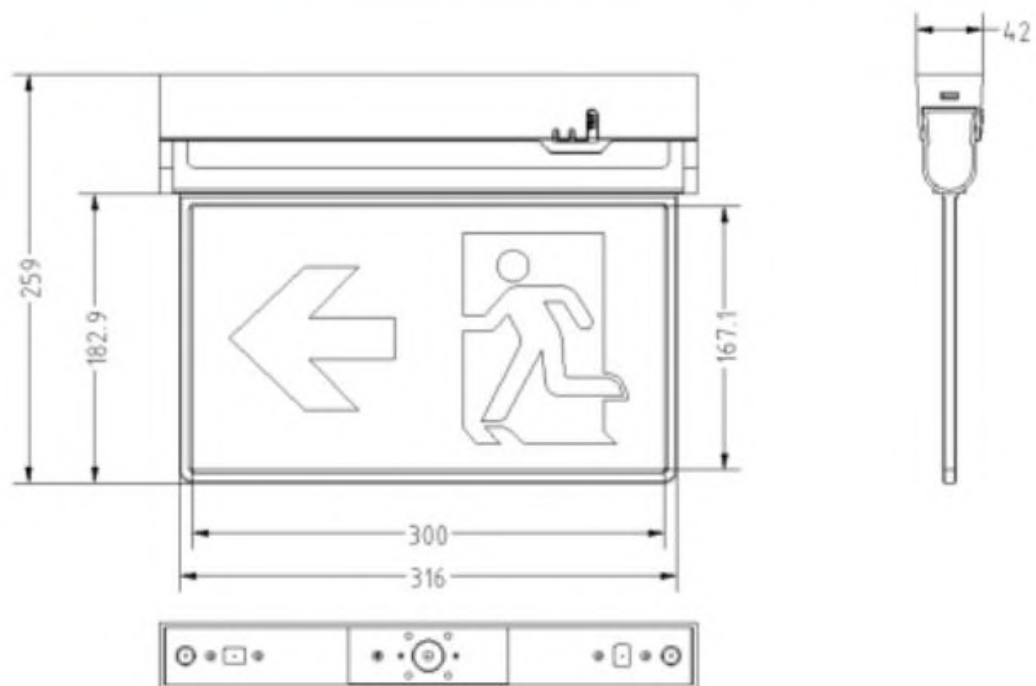

SPECIFICATION

- Input Voltage : DC36V(DCIS-40V)
- CRI>80
- Mounting Method : Ceiling/Wall/Recessed/
Suspend/End mount
- Battery Charge Time : 24H
- Emergency Time : 3H
- Operation Model : Maintained
- Viewing distance : 30M
- IP Level : 1P20
- Certificate : UL

PRODUCT DATA SHEET

ADDRESSABLE CEILING / WALL MOUNTED EXIT LIGHT

FRN-B5508U

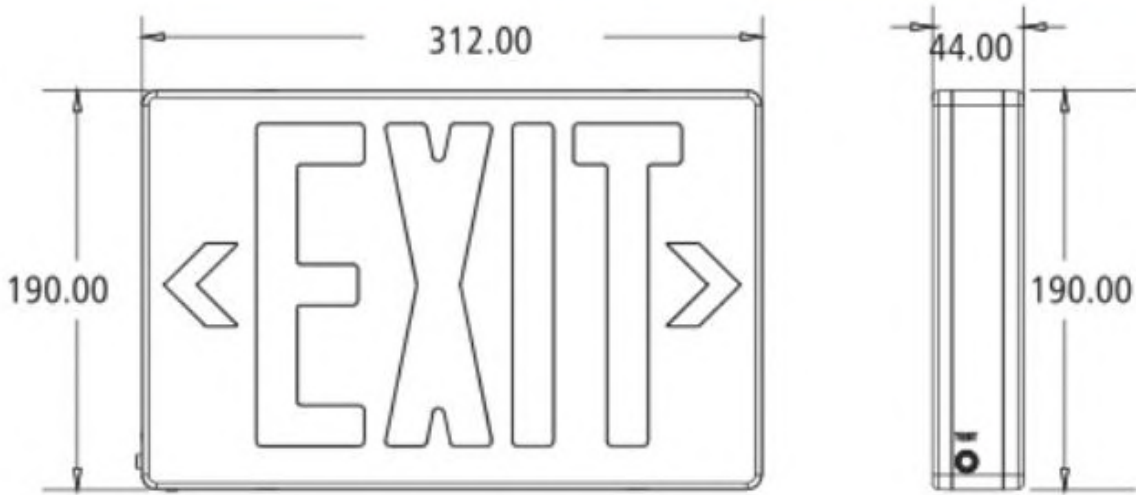

SPECIFICATION

- Input Voltage : DC36V(DC15-40V)
- Mounting Method : Ceiling/Wall/End mount
- Battery Charge Time : 24H
- Emergency Time : 3H
- Operation Model: Maintained
- Battery : Ni-Cd 1.2V 900mAh
- IP Level : IP20
- Certificate : UL



PRODUCT DATA SHEET

ADDRESSABLE RECESS MOUNTED EMERGENCY LIGHT FRN-Z1805U

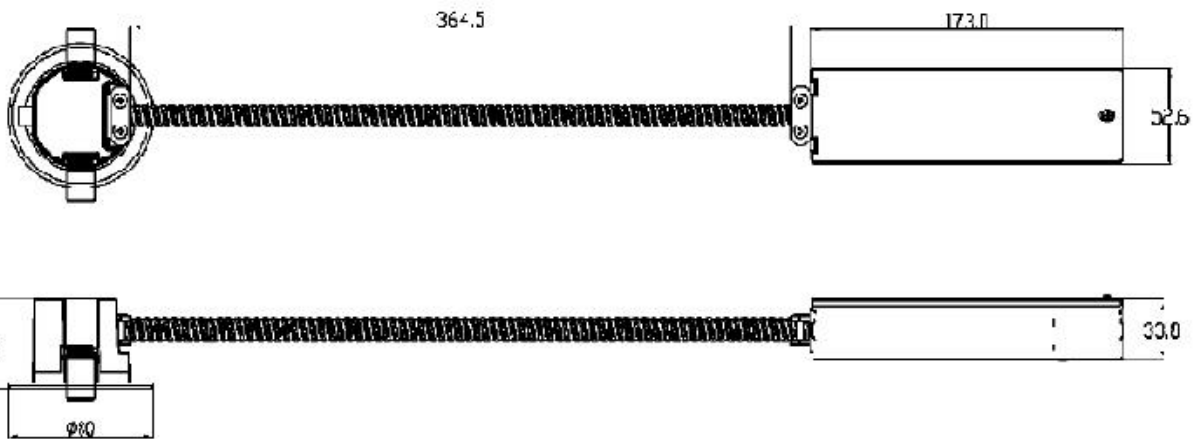

SPECIFICATION

- Input Voltage : DC36V(DC15-40V)
- Mounting Method : Recessed
- Light Source : SMD 3535 x 1pc
- CRI>70
- Lumen Output : 3001m
- Battery Charge Time : 24H
- Emergency Time : 3H
- Operation Model : Non-Maintained
- Battery : LiFePo4 3.2V 3600mAh
- IP Level : IP20
- Certificate : UL

PRODUCT DATA SHEET

ADDRESSABLE SURFACE MOUNTED EMERGENCY LIGHT FRN-Z2805U

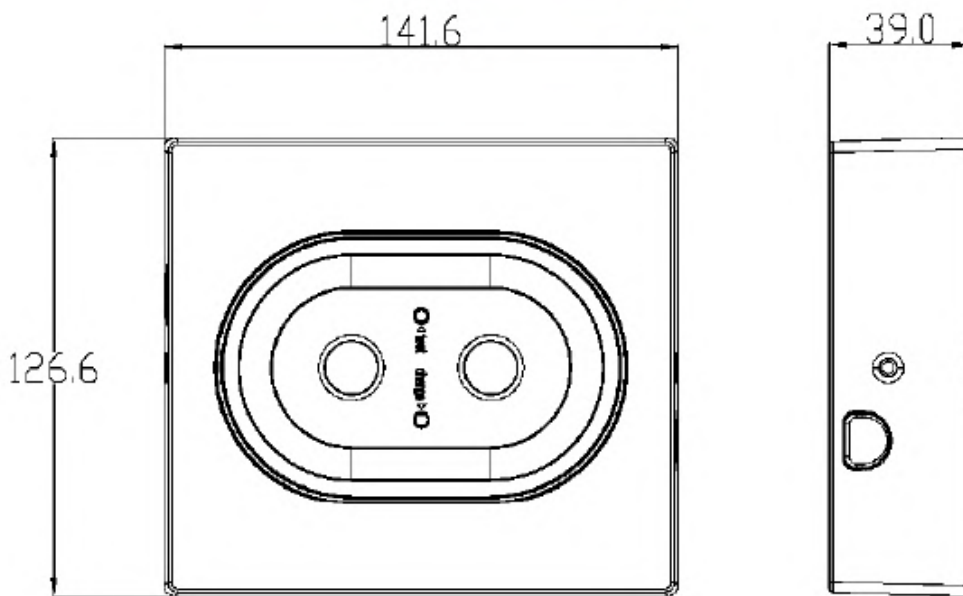

SPECIFICATION

- Input Voltage : DC36V(DC15-40V)
- Mounting Method : Surface
- Light Source : SMD 3535x1pc
- CRI >70
- Lumen Output : 3001m
- Battery Charge Time : 24H
- Emergency Time : 3H
- Operation Model : Non-Maintained
- Battery : LiFePo4 3.2V 3600mAh
- IP Level : IP20
- Certificate : UL





CONVENTIONAL EMERGENCY/EXIT LIGHTS



PRODUCT DATA SHEET

CONVENTIONAL EMERGENCY LIGHT

PRODUCT SPECS	Product Name	Emergency Light
	Product Model	FRN 2145
	Battery	Ni-Cd SC3.6V 1500mAh
	Charge Time	24H
	Emergency Duration	3H
	PCB Type	CEM-1 /1.6MM
	Self-contained or central power supply	Self-contained
	Case/color	White
	Viewing Distance	NA
	Degree of Protection	IP65
	Classification of Luminaires	NA



PRODUCT DATA SHEET

PRODUCT SPECS	Classification of Luminaires	NA
	Certification Standard	UL924
	Operation Temperature	0°C-40°C
	Warranty (Years)	1 Years
ELECTRICAL	Input Voltage	VAC 120~277
	Frequency	50Hz / 60Hz
	Input Current	0.075A (maintained) 0.025A (non-maintained)
	Input Power	5W (maintained) 1.5W (non-maintained)
	Operation Mode	Maintained/Non-maintained
	Emergency Power	1.3W(3.6V)
OPTICAL	Power Factor	-
	LED Package Type	SMD 2835/0.2W
	LED Qty	27pcs
	Correlated Color	6500k
	Luminance Flux	150 LM
	Emergency LuminanceFlux	150 LM
STRUCTURAL	Color Render Index	Ra80
	Dimension(mm)	352×110×68MM
	Mounting Type	Wall mounted
	Cover Material	PC
	Housing Material	PC
	Net Weight	0.65KG



PRODUCT IMAGE



PRODUCT DATA SHEET

CONVENTIONAL EXIT LIGHT

SL#	DESCRIPTION	BRAND	MODEL	APPROVAL
1	EXITLIGHTWALL MOUNTED	FRONTIER	FRN B5108U-G	

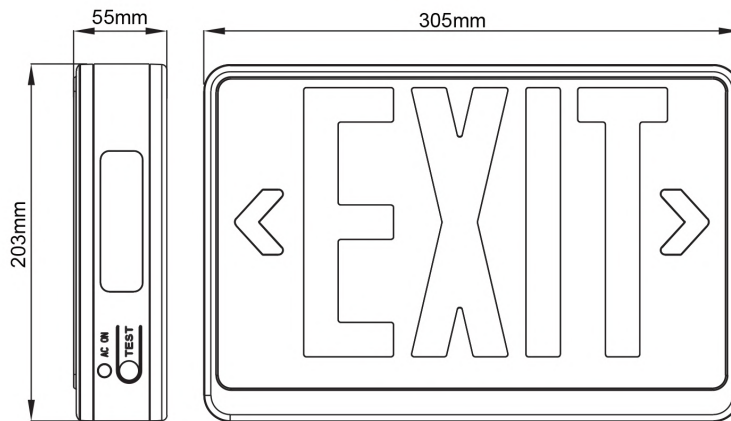

MODEL NAME	FRN-B5108U-G
Rated voltage	AC120-277V~, 60Hz
Rated Wattage	1.2W
Emergency Output Rating	0.36W
Emergency Run Time	180 Minutes
Battery	Ni-Cd 1.2V, 900mAh
Battery lift	up to 4 years
Recharge Time	24 hrs
Operating Temp Range	0°C-40°C
Dimensions	305x203x53mm
Weight	0.85kg



VOICE EVACUATION SYSTEM



DIGITAL NETWORK PA & VOICE ALARM CONTROLLER

FRNVA-6000MA



DESCRIPTIONS

VA-6000MA is a controller for public address (PA), voice evacuation. It can control the complete system and check the status through its 5" colorful touchscreen or through PC management software, to realize automatic monitor and management for each zone and each terminal, and realize automatic executing pre-programmed control. Built-in programmable trigger input and output interface is used for linkage control by used together with the sound and light alarm module(it can also be linked with the bus fire linkage controller).

FEATURES

- 5 inch HD color touch graphical operation interface.
- One key touch for emergency alarm.
- Support zone selection, zone distribution, grouping operation, the volume can be adjusted independently.
- Support user-defined zone name, group name, host name (when multi hosts cascading), easy to operate and manage.
- Support event trigger, timing trigger control output.
- Support zone monitor, equipment status real-time check.
- Support event trigger call, can be set re-calling times when no answer.
- Integrated 4 independent players (supports MP3 and wma audio formats).
- Support lines redundant wiring.
- Ethernet online configuration, control interface can work offline.
- Can connect up to 4 remote microphones which distance is 600 meters and support microphone circuit redundancy wiring.
- Support linkage to bus fire controller (Sanjiang 9100 and 9000 series of fire linkage controller).



BASIC FUNCTIONS

- Integrated with 1 independent background music player, support fixed time, fixed zone, fixed song, and specify playback mode playing, support MP3 and WMA audio format.
- Integrated with 1 independent voice message player, convenient for replacing voice message and language according to actual applications.
- Integrated with 2 independent EVA voice message players; support programmable staged evacuation alarm mode and specified partition evacuation alarm mode, evacuation alarm and warning will be played at the same time.
- Integrated with 1 channel analog telephone interface, convenient for remote telephone paging.
- 4 channel line input (one is optional for line or ordinary microphone), 1 audio output, audio output for external system recorder, for in on emergency call speech recording.
- 4 remote MIC interface, connected to VA-6000RM remote microphone. All paging stations connected with the standard RJ-45 network and CAT-5 network, using long-distance parallel transmission mode for voice transmission, the distance is up to 600 meters.
- 8 level signal or no voltage short circuit (or with voltage which determined by program, default is no voltage) input terminal, (con be regarded as 8 quick control key), each shortcut key functions can be specified , such as: ploy language message to specified zones or open external power supply to trigger a third party equipment to achieve the event triggering warning.
- Real time diagnosis, treatment, record ≤ 1000 , support sound, light alarm and prompt maintenance, troubleshooting when abnormal.
- Support basic Window platform visual operation interface, status automatic synchronization, classification rights management to ensure the security system.
- System support for third party online without voltage relay input and output interface.
- Host has backup function, by adding multiple hosts to ensure the system safety and expand audio source, increase system control point (Note, Please configure VA-6000ST before increasing host, otherwise the increased host can't operate, the host will automatically remind user to reconfigure}.

SPECIFICATIONS

Model	VA-6000MA
Electrical Specifications	
AC Power Supply	
Voltage	~220-240V 50/60Hz
Maximum Current	Less than 0.2A
Specification Of The Fuse	250V/2A, slow type
Power	36W
OC Power Supply	
Voltage	24V OC, $\pm 20\%$
Maximum Current	1.5 A
Performance Index	
Emergency Microphone	
Sensitivity	5mV
Impedance	600 Ω
Line input	
Distortion	<1 % (roted output power), 1 KHz
Frequency	80Hz ~ 20KHz
Sensitivity	775mV
Impedance	10K Ω
S/N Ratio	>70dB
Record Output	
Distortion	<1 % (roted output power), 1KHz
Frequency	200mV
Sensitivity	>70dB
Contact Output	
Fault Relay Output	Short circuit, no voltage
Fire linkage Relay Output	Short circuit, no voltage
8 Relay Programmable Output	Short circuit, no voltage
Programmable OC24V Power Outputs	+DC 24V, 1A
8 Programmable Trigger Input	
Level Model	highest 3.3V
Short Circuit Mode	Short circuit, no voltage
Short Circuit Input	
Fire Reset Input Contact	Pulse ≥ 0.55 , no voltage
Voice Message	
Data Format	MP3 or WMA format
Storage Type	SD
Information Capacity	65535 (programmable maximum 255)
Storage Time	> 10 years
Log Information	
Data Format	HEX
Storage Type	Nand Flash
Information Capacity	1000
Storage Time	> 10 years
Mechanical Index	
Size (L x W x D)	484 x 132 x 449 mm (19 inches wide, 19 inch high)
Weight	About 8.0 Kg
Installation	Desktop or 19 inch cabinet
Color	Block
Environmental Requirements	
Operating Temperature	+5°C~+40°C
Storage Temperature	-20°C~+70°C
Relative Temperature	<95%



FIREPROOF CEILING SPEAKER

FRNVA-104C / FRNVA-105C

DESCRIPTIONS

- 4" / 5" fireproof version ceiling speaker
- Ceramic connector, thermal use and fire-resistant cable
- 6 watts at 100v output
- All metal material design with fire dome
- Fast installation by spring clip
- Economy cost solution
- Excellent response for background music and voice message
- EN54-24 Certification is under taken

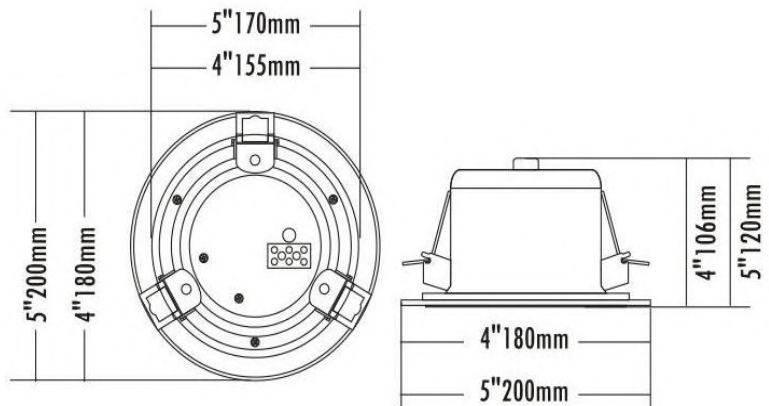

Model	VA-104C	VA-105C
Power Taps @100V	6W	6W
Power Taps @70V	3W	3W
Impedance	COM/1.7KΩ	COM/1.7KΩ
SPL(1W/1M)	89dB	90dB
Frequency Response (-10dB)	110-16KHz	110-18KHz
Finish	Baffle: Steel, White	Baffle: Steel, White
	Grille: Aluminum, White Cover: Steel, Orange	Grille: Aluminum, White Cover: Steel, Orange
Speaker Driver	4" x 1	5" x 1
Cutout Size	155mm	170mm
Dimensions	180 x 106mm	200 x 120mm
Weight	0.9Kg	1Kg
Mounting	Spring-clip	Spring-clip

WALL MOUNT LOUDSPEAKER

FRNVA-611

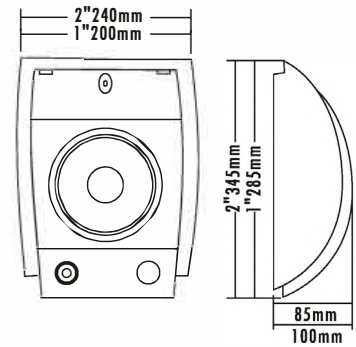

Model	VA-611
Power Tops@100V	1.5W, 3W, 6W
Power Tops@70V	0.75W, 1.5W, 3W
Impedance	Black: COM Red: 6.7KΩ / 3.3KΩ / 1.7KΩ
SPL(1W/1M)	90dB ±3dB
Mox. SPL (Rated1W/1M)	98dB
Frequency Response (-10dB)	90-1BKHz
Finish	Baffle: ABS, White Grille: Steel, Gray
Speaker Driver	5" X 1 2" x 1"
Dimensions	285 x 200 x 85mm
Weight	1.3Kg
Mounting	Spring-clip





FIRE RESISTANT CABLES



FIRE RESISTANT CABLES

(2C X 1.0 sq.mm)

FIRE ALARM CABLE SHIELDED SERIES

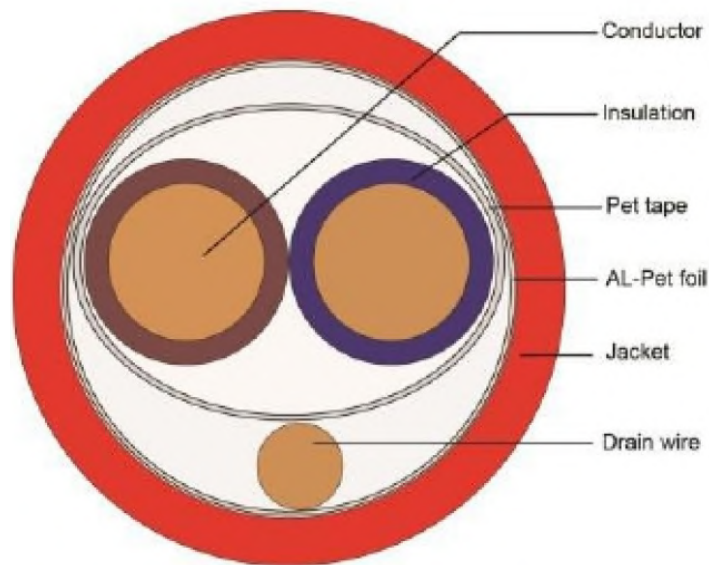

APPLICATION

Fire Protective Signaling Circuits, Smoke detectors, Strobes/Sirens, Pull stations Voice communications, Burglar alarms, Audio, control, initiating & notification circuits, Microprocessor/Addressable Controlled Systems.

STANDARDS

UL Standard: UL 13 & UL 1424 & UL 444

Flame Rating: UL 1666 Riser c(UL) FT4

RoHS: Compliant Directive 2011/65/EU



FIRE RESISTANT CABLES

(2C X 1.0 sq.mm)

PHYSICAL STRUCTURE

1.1	Conductor Diameter	1.12±0.003mm	
1.2	Conductor Material	Solid Bare Copper, Wires	
1.3	Insulation Diameter	PVC, 1.92±0.05mm	
1.4	Insulation Material Colour	Brown & Blue	
1.5	Drain Wire	No. Strands	1
		Strand Size	0.80±0.003mm
1.6	Foil Shield Coverage	115% Polyester Foil, 1x20x0.025mm	
1.7	Drain Wire Material	Tinned copper wire	
1.8	Foil Shield Coverage	100% Single Aluminum Foil, 1x20x0.35mm	
1.9	Jacket Colour	PVC Red RAL3000 or as request	
1.10	Jacket Thickness	≥0.85mm	
1.11	Overall Diameter	5.80±0.20mm	

MECHANICAL PROPERTIES

Band radius	8 x D
Operating temperature range:	-20°C to 75°C

ELECTRICAL PROPERTIES

AT 20°C

Conductor Resistance	Ω/km	≤21.4
----------------------	------	-------

FIRE RATING

PVC: UL 1666



FIRE RESISTANT CABLES

(2C X 1.5 sq.mm)

PHYSICAL STRUCTURE

1.1	Conductor Diameter		1.37±0.003mm
1.2	Conductor Material		Solid Bare Copper, Wires
1.3	Insulation Diameter		PVC, 2.35±0.05mm
1.4	Insulation Material Colour		Brown & Blue
1.5	Drain Wire	No. Strands	1
		Strand Size	0.80±0.003mm
1.6	Foil Shield Coverage		115% Polyester Foil, 1x20x0.025mm
1.7	Drain Wire Material		Tinned copper wire
1.8	Foil Shield Coverage		100% Single Aluminum Foil, 1x20x0.35mm
1.9	Jacket Colour		PVC Red RAL3000 or as request
1.10	Jacket Thickness		≥0.85mm
1.11	Overall Diameter		6.50±0.20mm

MECHANICAL PROPERTIES

Band radius	8 x D
Operating temperature range:	-20°C to 75°C

ELECTRICAL PROPERTIES

AT 20°C

Conductor Resistance	Ω/km	≤12.0
----------------------	------	-------

FIRE RATING

PVC: UL 1666



FIRE RESISTANT CABLES

(2C X 2.5 sq.mm)

PHYSICAL STRUCTURE

1.1	Conductor Diameter	1.76±0.003mm	
1.2	Conductor Material	Solid Bare Copper, Wires	
1.3	Insulation Diameter	PVC, 2.75±0.05mm	
1.4	Insulation Material Colour	Brown & Blue	
1.5	Drain Wire	No. Strands	1
		Strand Size	0.80±0.003mm
1.6	Foil Shield Coverage	115% Polyester Foil, 1x20x0.025mm	
1.7	Drain Wire Material	Tinned copper wire	
1.8	Foil Shield Coverage	100% Single Aluminum Foil, 1x20x0.35mm	
1.9	Jacket Colour	PVC Red RAL3000 or as request	
1.10	Jacket Thickness	≥0.85mm	
1.11	Overall Diameter	7.40±0.20mm	



MECHANICAL PROPERTIES

Band radius	8 x D
Operating temperature range:	-20°C to 75°C

ELECTRICAL PROPERTIES

AT 20°C

Conductor Resistance	Ω/km	≤7.5
----------------------	------	------

FIRE RATING

PVC: UL 1666



END SUCTION FIRE PUMP



END SUCTION FIRE PUMP

Sectional & Dimensional Drawings

CN125-100/250

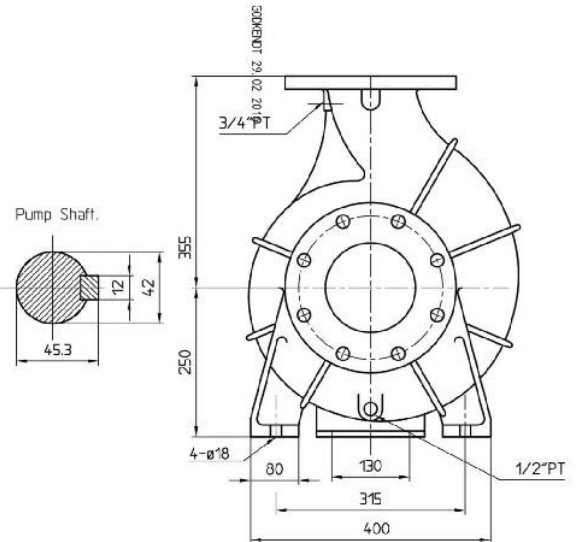
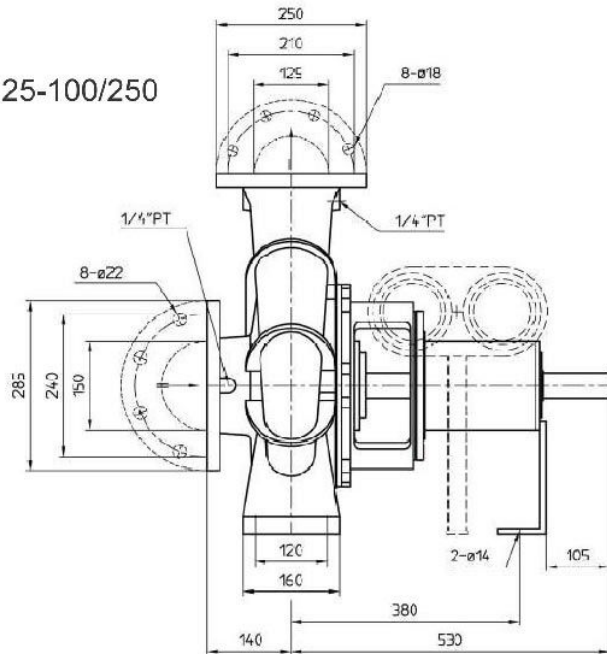

CN150-125/250

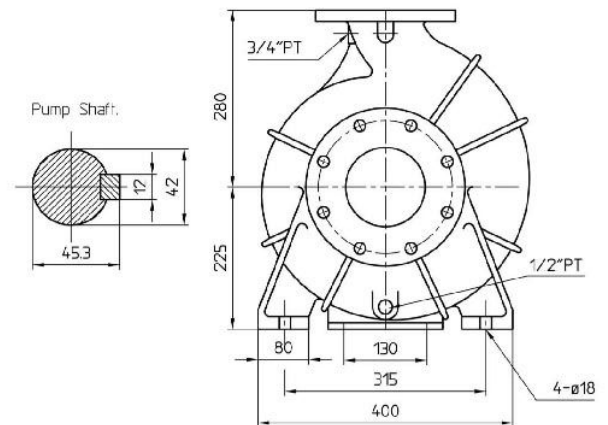
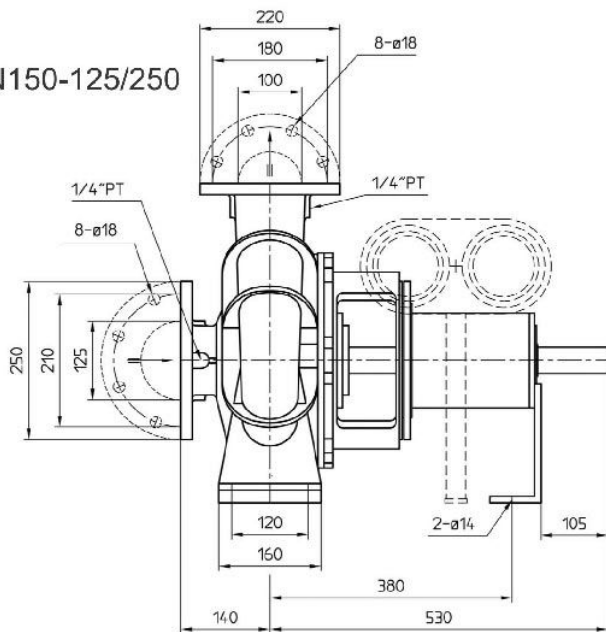

END SUCTION FIRE PUMP

Sectional Drawings

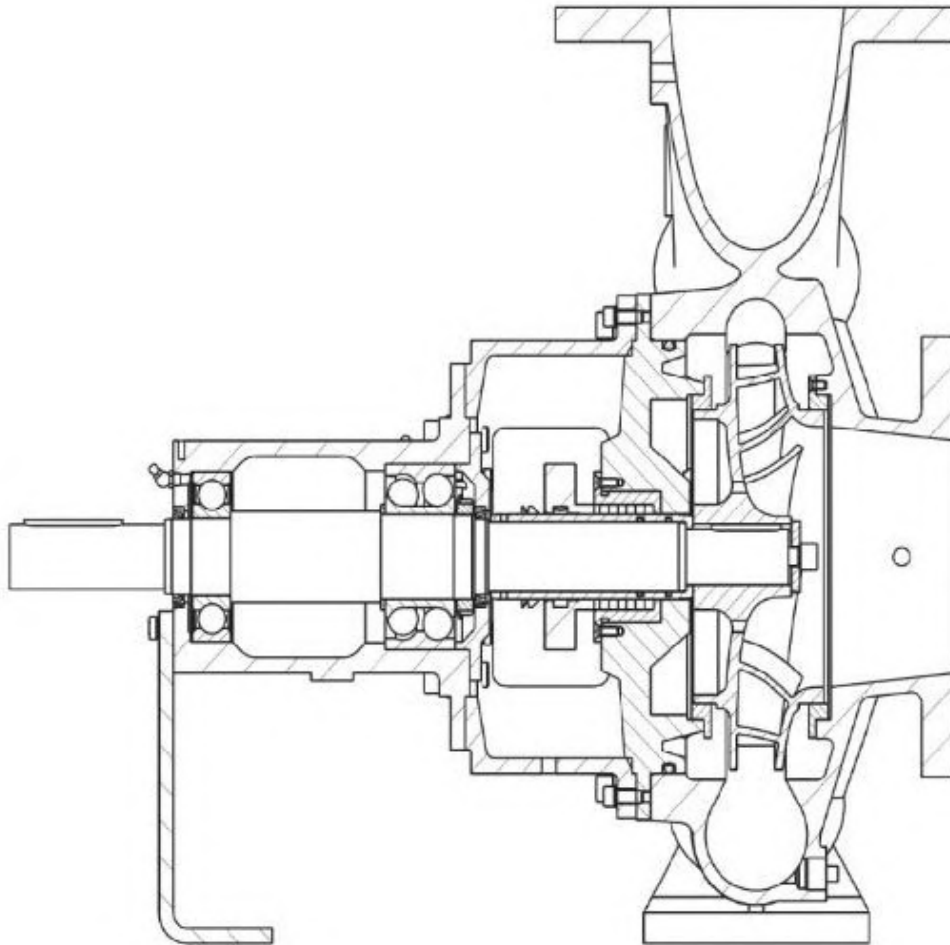
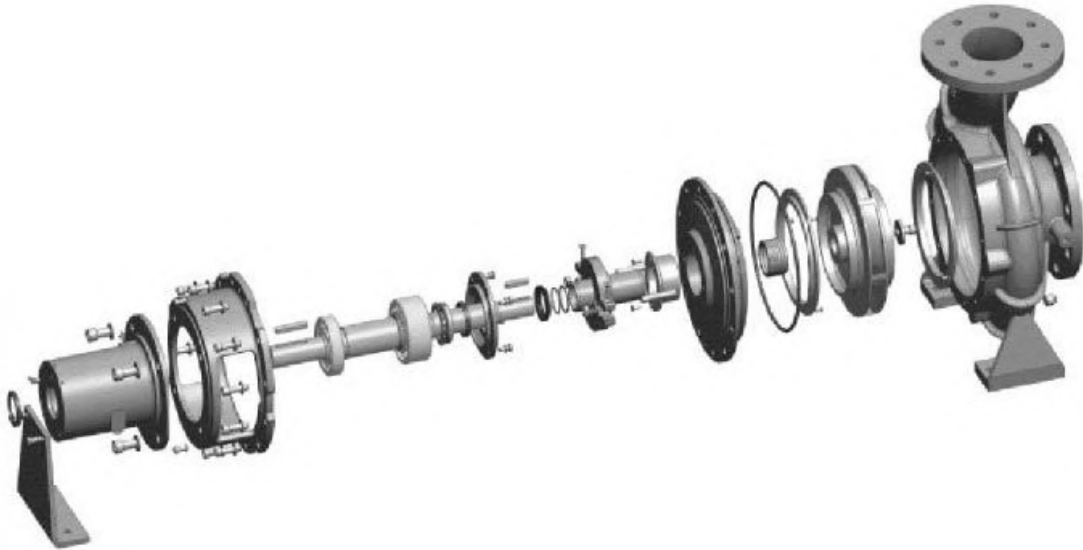

END SUCTION FIRE PUMP

Performance Range

PERFORMANCE RANGE OF PUMP-END SUCTION (50Hz)

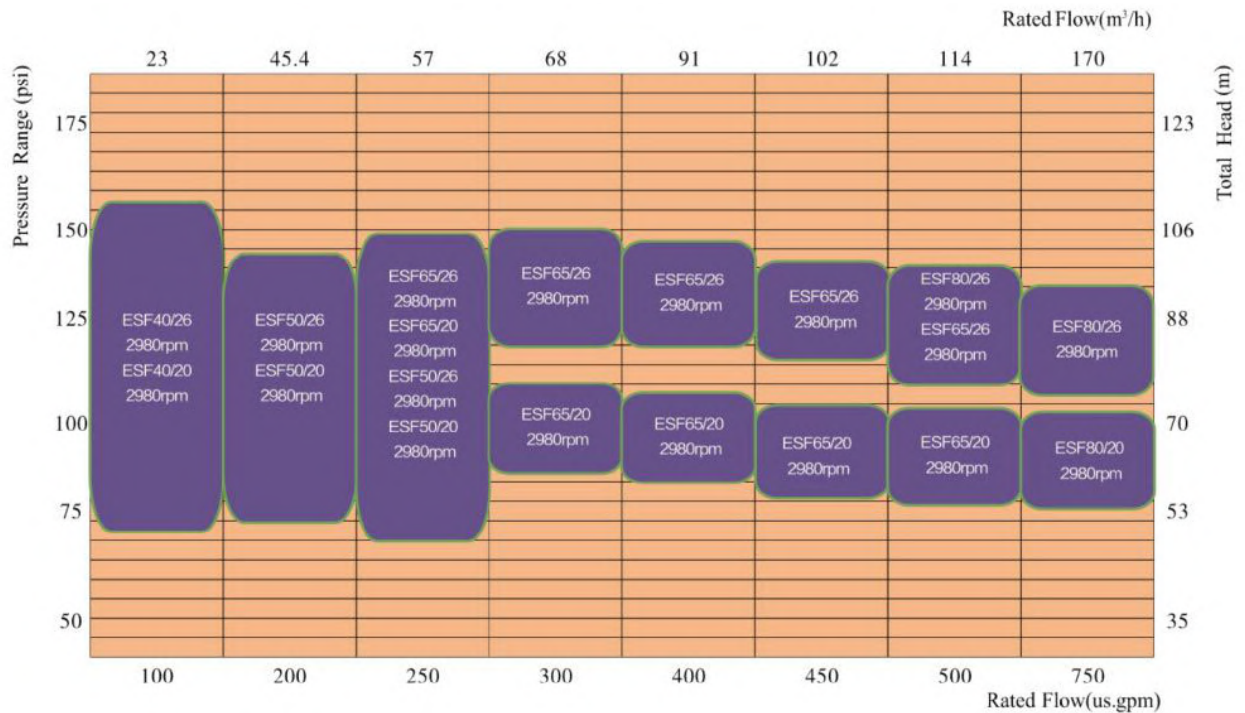

PERFORMANCE RANGE OF END SUCTION FIRE PUMP - (60Hz)

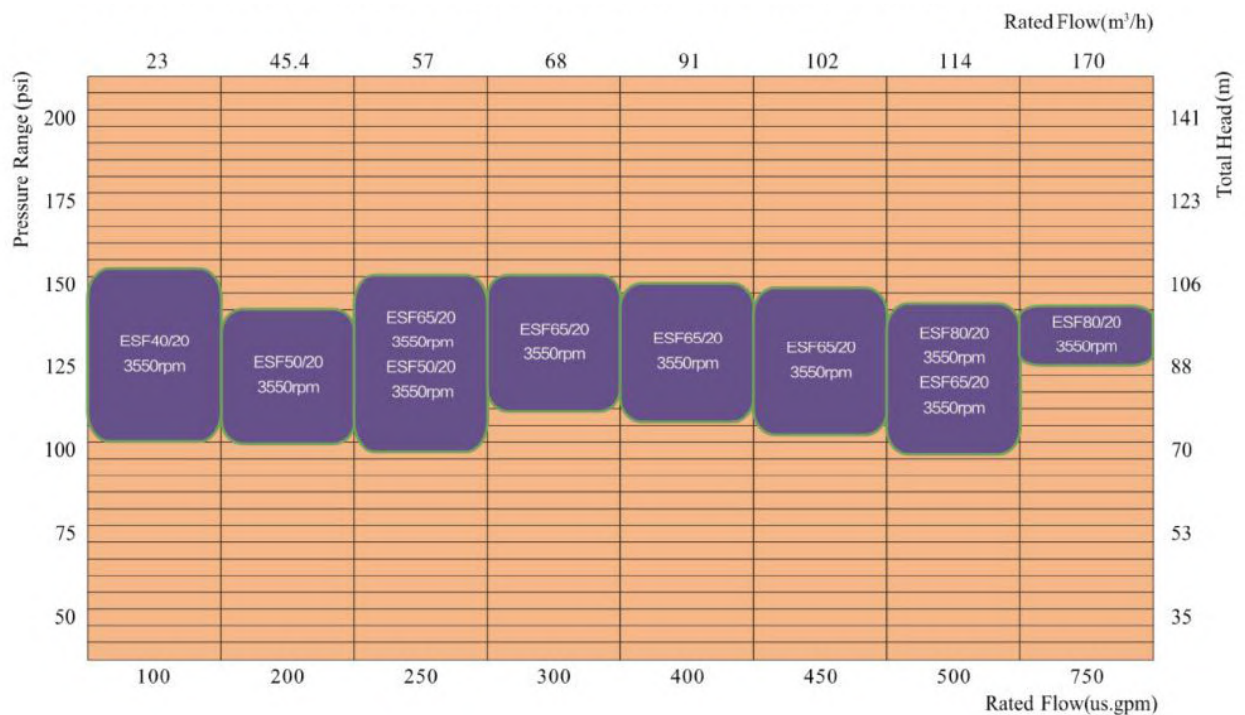

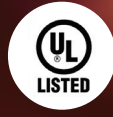

HORIZONTAL SPLIT CASE FIRE PUMP



HORIZONTAL SPLIT CASE FIRE PUMP

Sectional Drawings

REF	DESCRIPTION	MATERIAL
1213	Casing half lower	Cast iron - G30
1214	Casing half upper	Cast iron - G30
1500	Casing wear ring	Bronze
2100	Shaft	Stainless steel
2200	Impeller	Bronze
2400	Sleeve	Bronze
2910	Shaft nut	Bronze
3011	Radial ball bearing	-
3012	Radial roller bearing	-
3200	Bearing housing	Cast iron - G30
4100	Staffing box	Bronze
4130	Gland packing	PTFE
4200	Mechanical seal	On request
6262	Pipe	Stainless steel

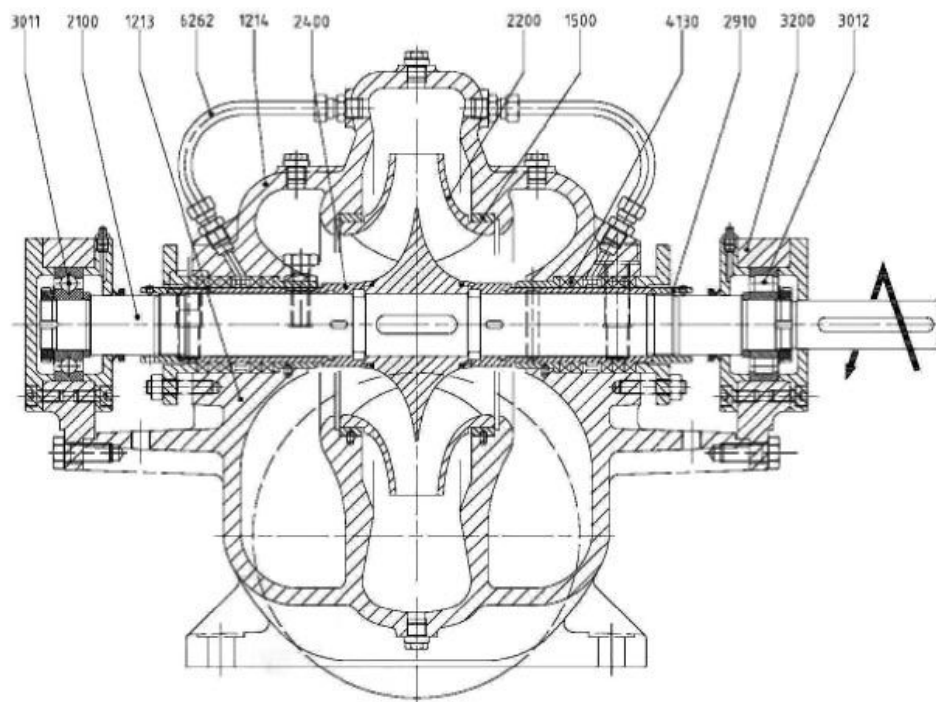
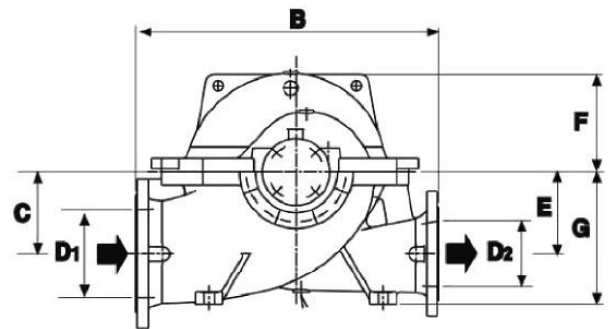
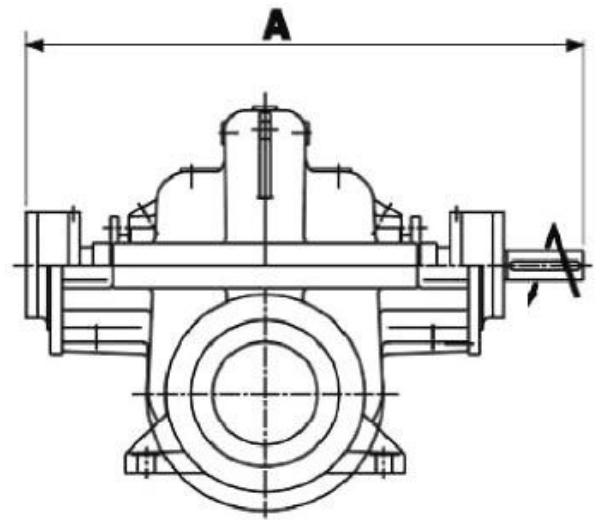

HORIZONTAL SPLIT CASE FIRE PUMP

Technical Data Summary

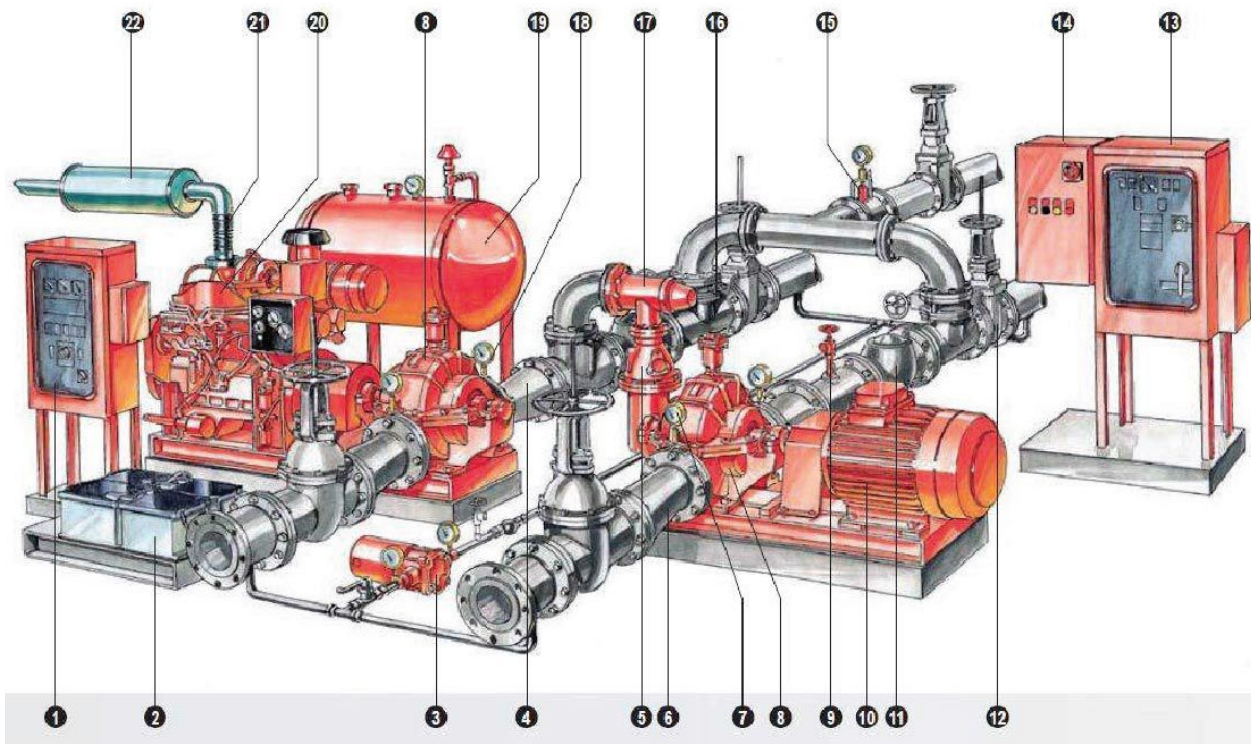

**HORIZONTAL FIRE PUMPS DIESEL ENGINE DRIVEN,
U.L. APPROVED RANGE**

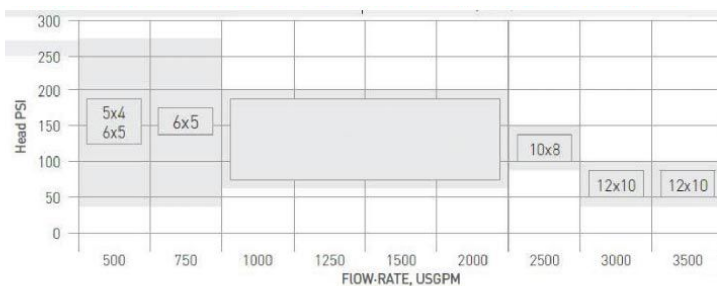

**HORIZONTAL FIRE PUMPS DIESEL ENGINE DRIVEN,
U.L. APPROVED RANGE**

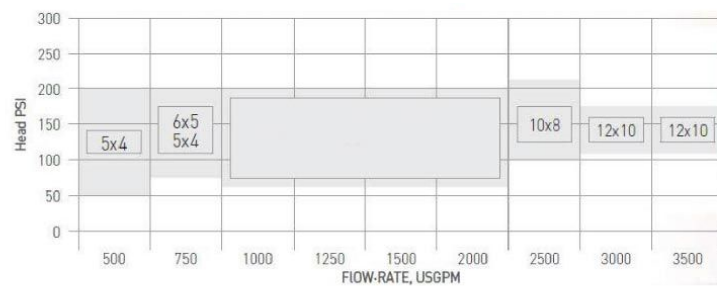

- | | |
|----|-------------------------------------|
| 1 | Diesel engine fire pump controller |
| 2 | Batteries |
| 3 | Jockey pump |
| 4 | Concentric discharge increaser |
| 5 | Enclosed discharge overflow cone |
| 6 | Eccentric suction reducer |
| 7 | Suction pressure gauge |
| 8 | Horizontal pump |
| 9 | Circulation relief valve |
| 10 | Electric motor |
| 11 | Check valve |
| 12 | OS & Y gate valve |
| 13 | Electric motor fire pump controller |
| 14 | Jockey pump controller |
| 15 | Flow meter |
| 16 | Automatic air release valve |
| 17 | Main relief valve |
| 18 | Discharge pressure gauge |
| 19 | Fuel tank |
| 20 | Diesel engine |
| 21 | Flexible exhaust connector |
| 22 | Exhaust muffler |



HORIZONTAL SPLIT CASE FIRE PUMP Performance Range

Centrifugal Fire Pumps, Horizontal Split-Case Type

UL SCF SINGLE STAGE DOUBLE SUCTION FIRE PUMP PERFORMANCE RANGE (MOTOR 60HZ)

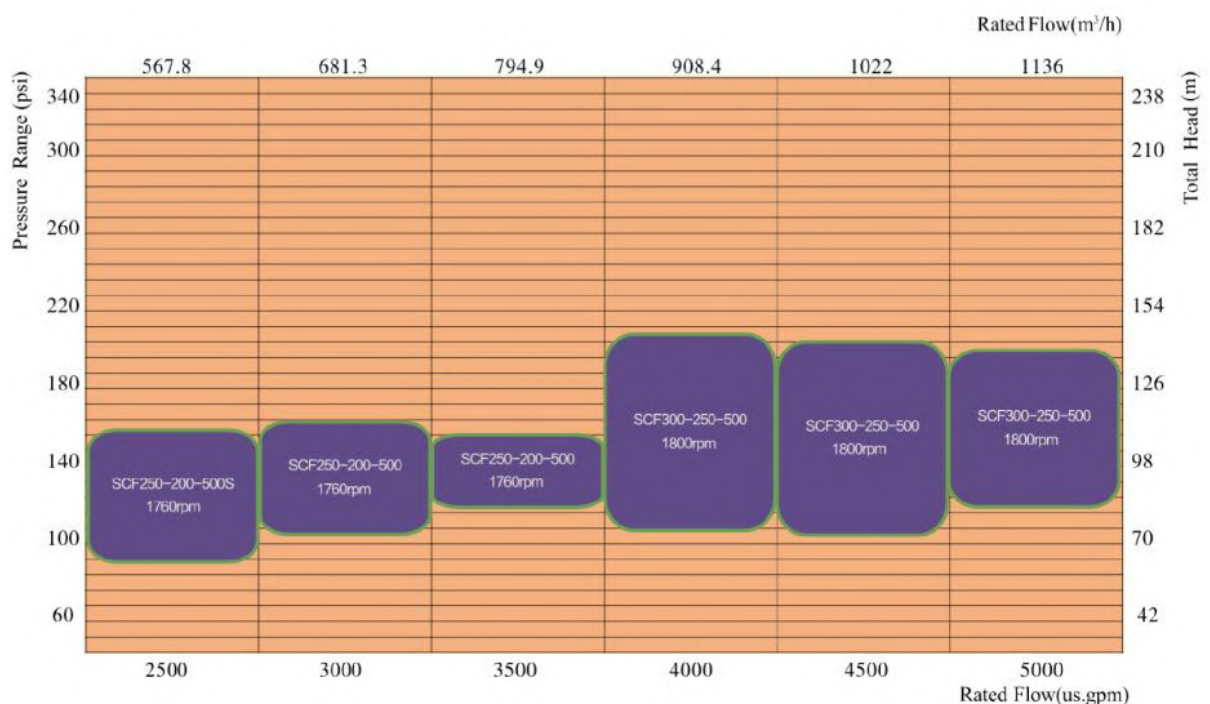
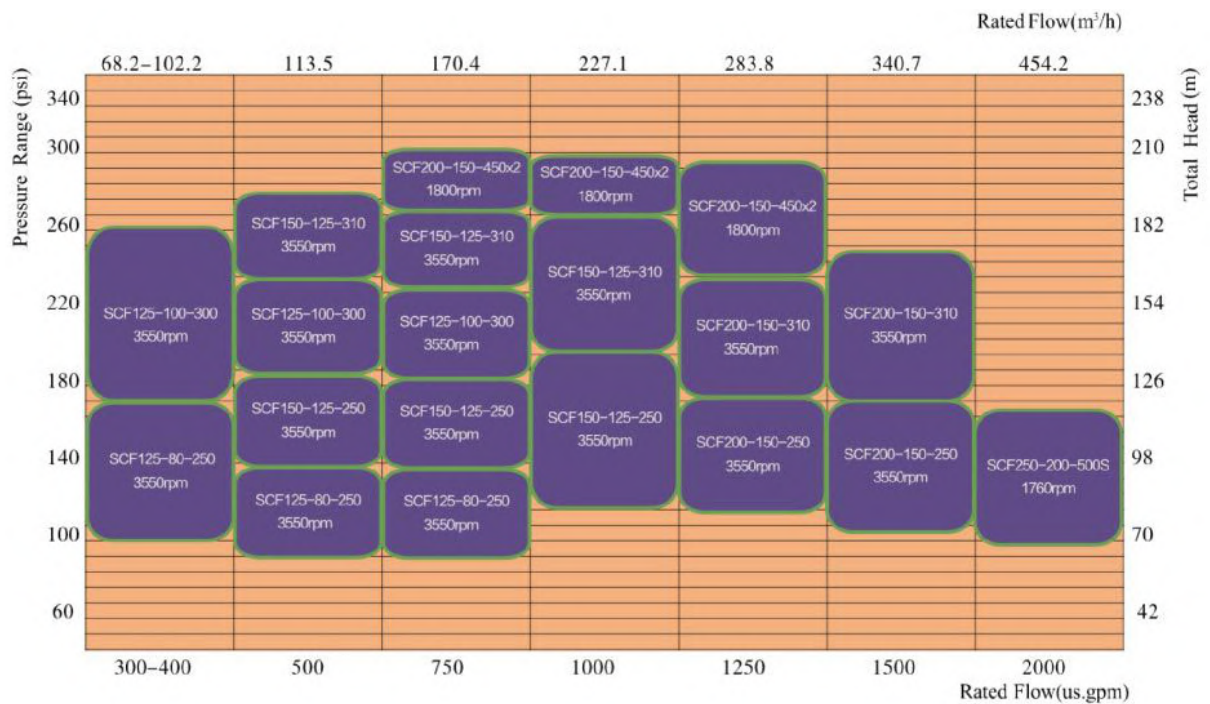

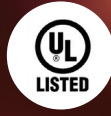

VERTICAL TURBINE FIRE PUMP

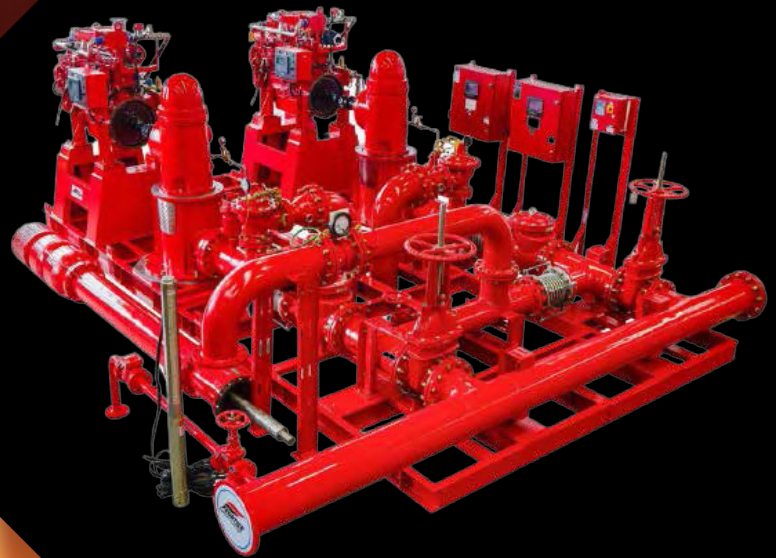

VERTICAL TURBINE FIRE PUMP

Vertical shaft turbine type fire pumps have submerged impellers contained in a series - bowl assembly at the bottom of a vertical shaft. The design is similar to the pumps used extensively for industrial & municipal services. These pumps are UL approved for discharging water from tanks, streams, open sumps, drilled wells. Each pumps consist of a discharge head, motor stand, column pipe, line shaft, bowl assembly and suction strainer.

TECHNICAL DATA SUMMARY

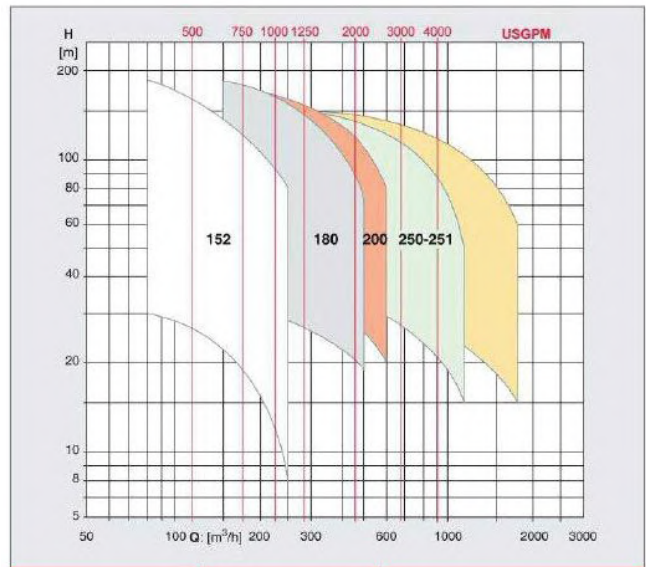

VERTICAL TURBINE FIRE PUMP

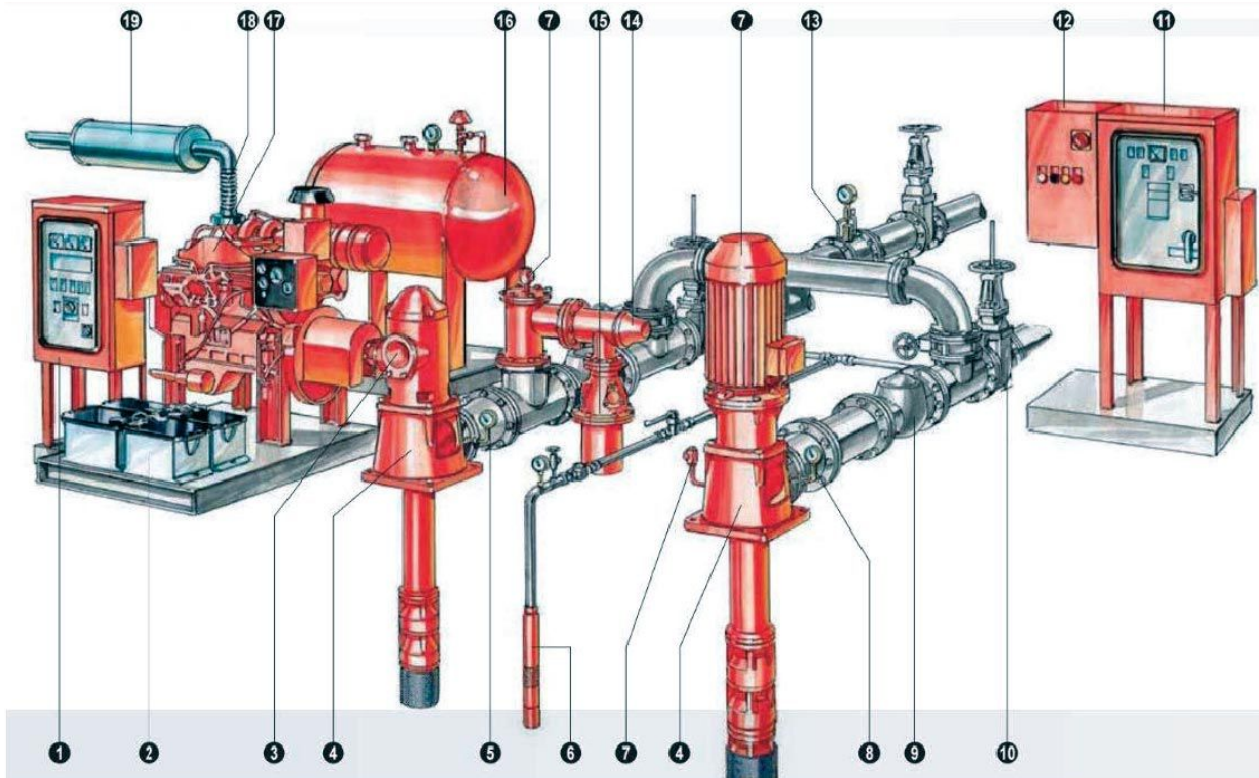

HORIZONTAL FIRE PUMPS DIESEL ENGINE DRIVEN, U.L. APPROVED RANGE



VERTICAL PUMPS AT 1100 RPM, APPROVED RANGE HEAD, PSI FLOW. RATE USGPM



- | | |
|----|-------------------------------------|
| 1 | Diesel engine fire pump controller |
| 2 | Batteries |
| 3 | Gear Drive |
| 4 | Pump |
| 5 | Suction Pressure Gauge |
| 6 | Jockey Pump |
| 7 | Circulation relief valve |
| 8 | Concentric discharge increaser |
| 9 | Check Valve |
| 10 | OS & Y gate valve |
| 11 | Electric motor fire pump controller |
| 12 | Jockey pump controller |
| 13 | Discharge pressure gauge |
| 14 | Main relief valve |
| 15 | Enclosed discharge overflow cone |
| 16 | Fuel Tank |
| 17 | Diesel Engine |
| 18 | Flexible Exhaust connector |
| 19 | Exhaust muffler |



VERTICAL TURBINE FIRE PUMP

Sectional Drawings

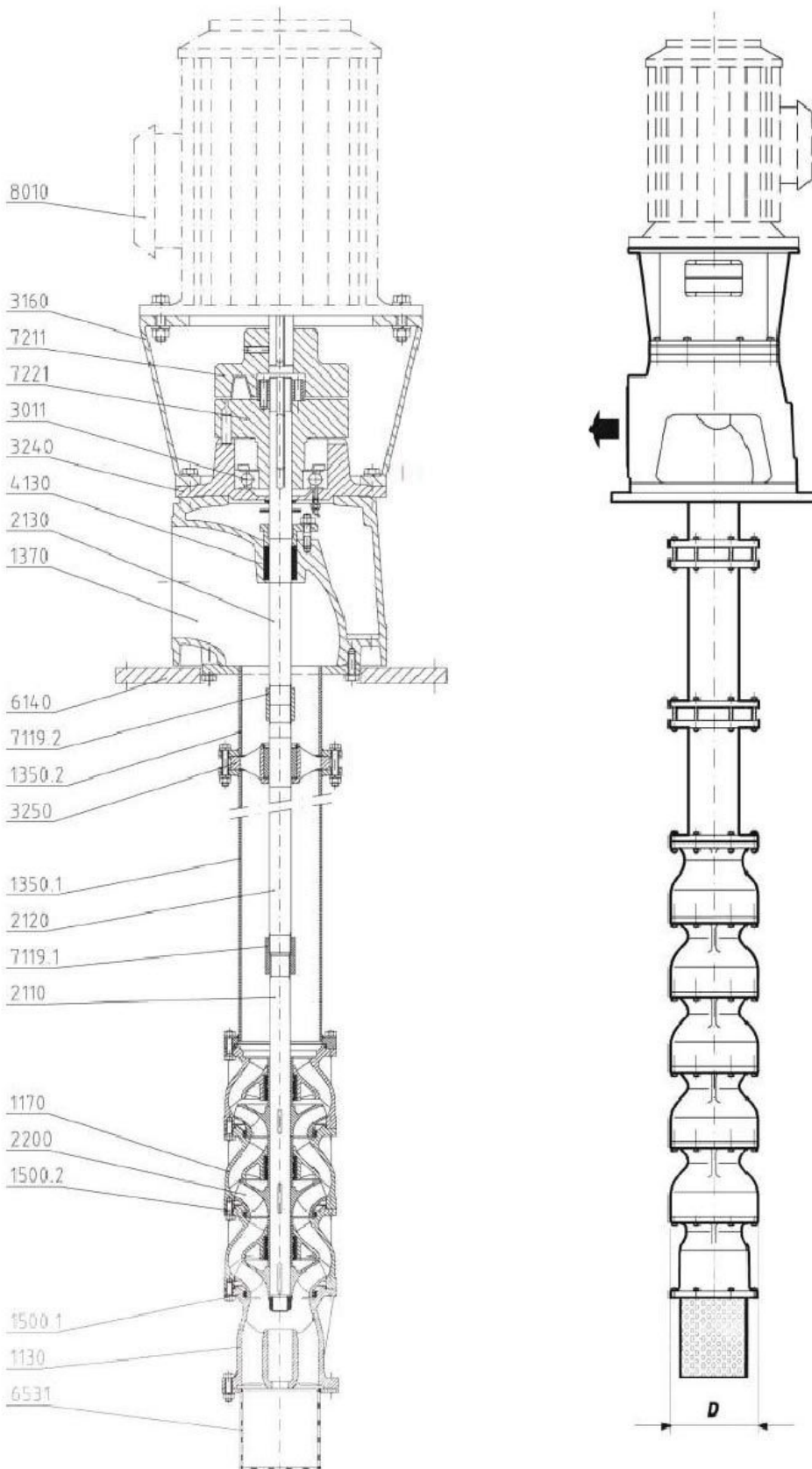

VERTICAL TURBINE FIRE PUMP

Sectional Drawings

TYPE D(“) D(MM)		
152	12"	290
180	12"	300
200	14"	354
250	17"	418
251	17"	418

REF	DESCRIPTION	MATERIAL
1130	Bell mouth	Cast iron – G25
1170	Pump bowl	Cast iron – G25
1350, 1	Column pipe	Stainless steel
1350, 2	Column pipe	Stainless steel
1370	Delivery casing	Cast iron – G25
1500, 1	Wear ring	Bronze
1500, 2	Wear ring	Bronze
2110	Pump shaft	Stainless steel
2120	Intermediate shaft	Stainless steel
2130	Top shaft	Stainless steel
2200	Impeller	Cast iron – G25
3011	Ball bearing	Stainless steel
3160	Motor spool	Cast iron – G25
3240	Bearing housing	Cast iron – G25
3250	Bearing bracket	Cast iron – G25
4130	Gland packing	Teflon Carbon
6140	Foundation plate	Steel Fe 430
6531	Suction strainer	Steel Fe 510
7119, 1	Screwed coupling	AISI 420
7119, 2	Screwed coupling	AISI 420
7211	Coupling half side motor	Cast iron – G25
7221	Coupling half side pump	Cast iron – G25



VERTICAL TURBINE FIRE PUMP

Performance Range

Centrifugal Fire Pumps, Vertical Shaft, Turbine Type

PERFORMANCE RANGE-CENTRIFUGAL FIRE PUMPS, VERTICAL SHAFT TURBINE TYPE

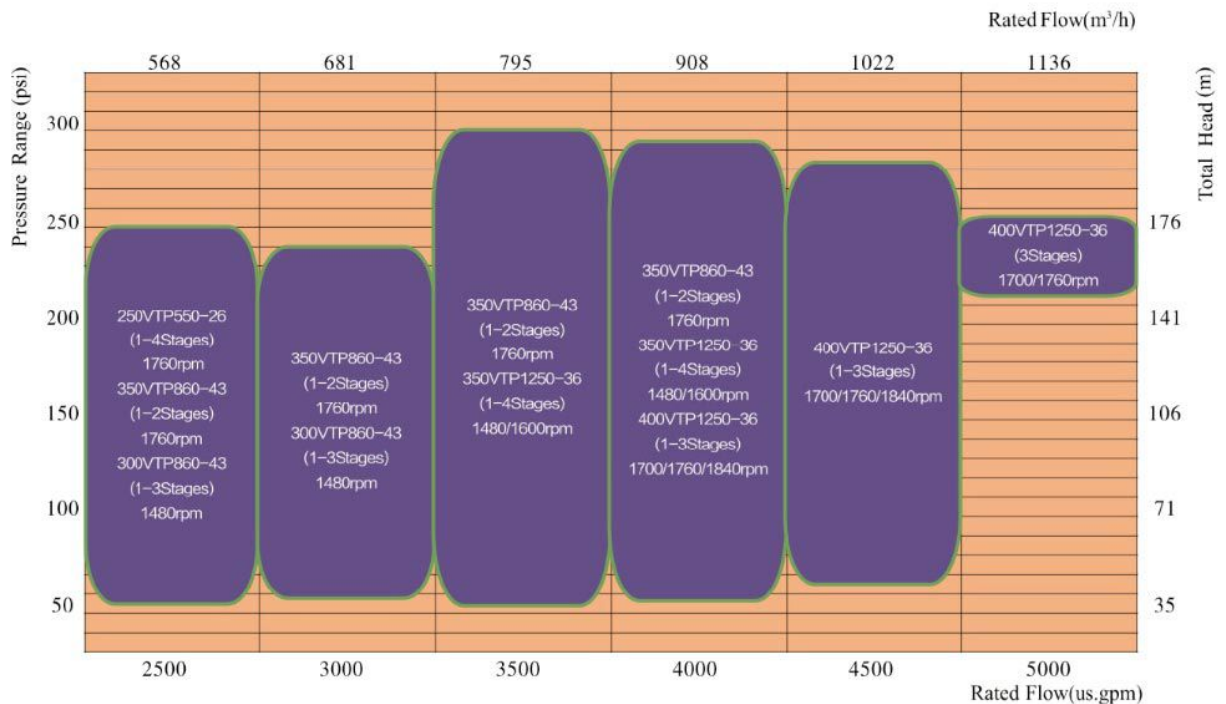
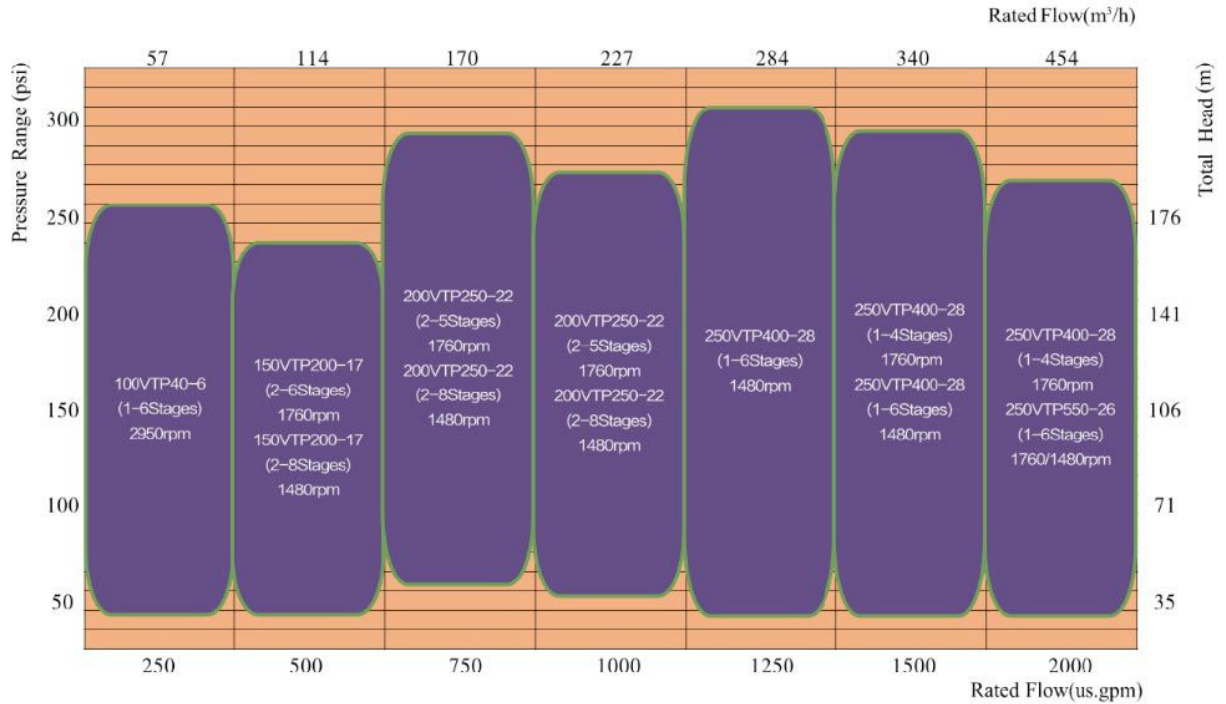



AUTOMATIC SPRINKLER HEAD



SPRINKLER HEAD

DESCRIPTION

Pendent and upright and conventional and sidewall sprinklers are designed for use in automatic sprinkler systems designed in accordance with standard installation (NFPA13). The temperature response is standard response 5mm glass bulb and fast response 3mm glass bulb. The sprinklers come with compact design available in different finishes and temperature ratings.

The sprinklers body is made of brass die-casting copper alloy (DZR). The spring seat consists of a spring Belleville washer coated on both side with a Teflon tape.

Pendent and conventional and sidewall sprinklers are installed with adjustable or non-adjustable escutcheon plates. These are intended to be installed finished ceilings. Escutcheon plate adjustment provides convenience in pendent and conventional sprinkler installation in case of areas with finished ceiling or walls.

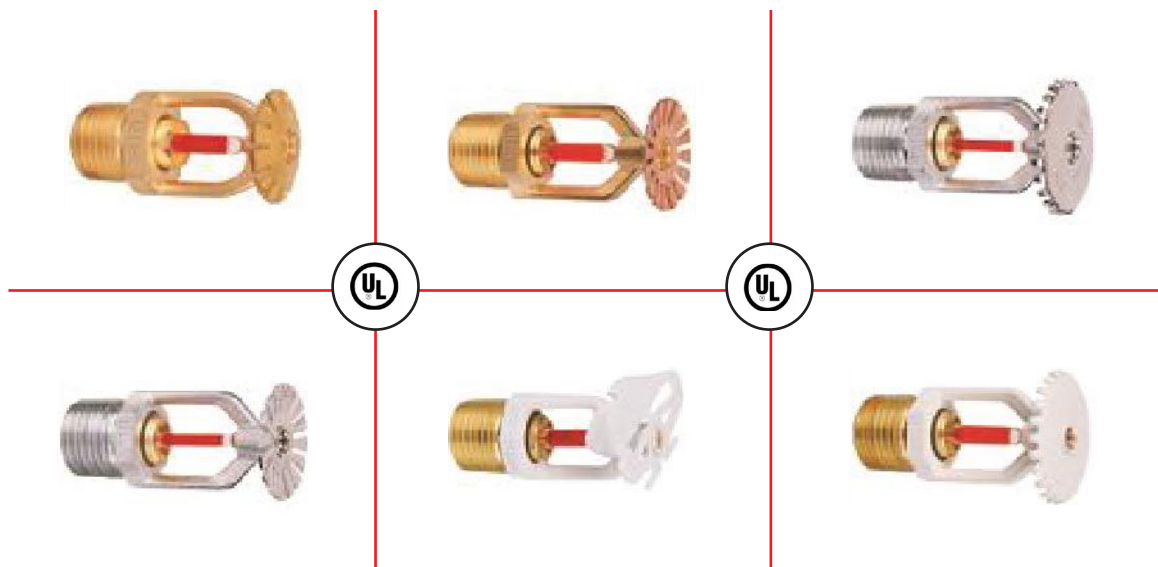

TECHNICAL SPECIFICATION

Style	Pendent, Upright, Sidewall, Conventional and Recessed Pendent, Recessed Sidewall, Recessed Conventional
K Factor gpm/(psi) ^{1/2} (L3/min(bar) ^{1/2})	5.6 (80)
Nominal Thread Size	1/2" NPT AND 1/2" BSPT
Max. Working Pressure	175 PSI (12BAR)
Factory Test Pressure	500 PSI (35BAR)
Min. Operating Pressure	7 PSI (0.5 BAR)
Finish	Brass and Chrome Plated and White Plated Available

SPRINKLER HEAD

TECHNICAL SPECIFICATION

SIN	Response Type	Sprinkler Style	Temp. Rating F (C)
FN001	SR	Sidewall	155 (68)
FN002	QR	Sidewall	155 (68)
FN003	SR	Upright	135 (57) 155 (68) 175 (79)
FN004	QR	Upright	155 (68)
FN005	SR	Pendent	135 (57) 155 (68) 175 (79)
FN006	QR	Pendent	155 (68)
FN007	SR	Conventional	155 (68)

MATERIAL SPECIFICATION

Deflector	Brass UNS-28000
Bulb	Glass with Glycerin Solution JOB GS or Day-impex-937 for Ut0001, Ut0003, Ut0005, Ut0007 JOB F3 or Day-impex-941 for Ut0002, Ut0004, Ut0006
Load Screw	Brass UNS-28000
Seal	Brass UNS-28000
Frame	Brass UNS-28000
Seal Washer	Belleville Washer coated on both sides with Teflon Tape
Bulb Nominal Diameter	Standard Response 5.0mm, Quick Response 3.0mm

EACH STYLE SPRINKLER DIMENSION

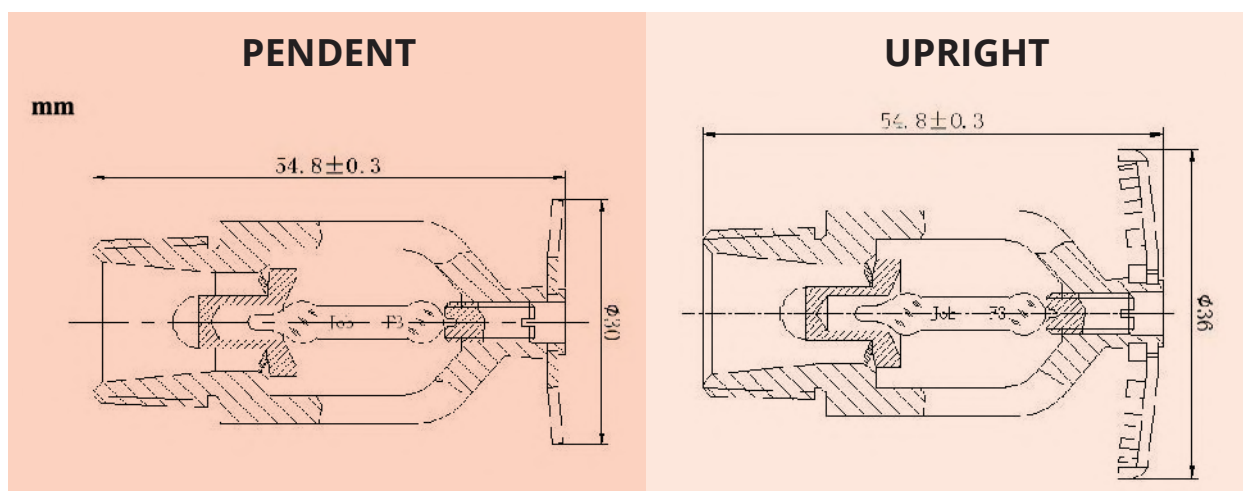

SPRINKLER HEAD

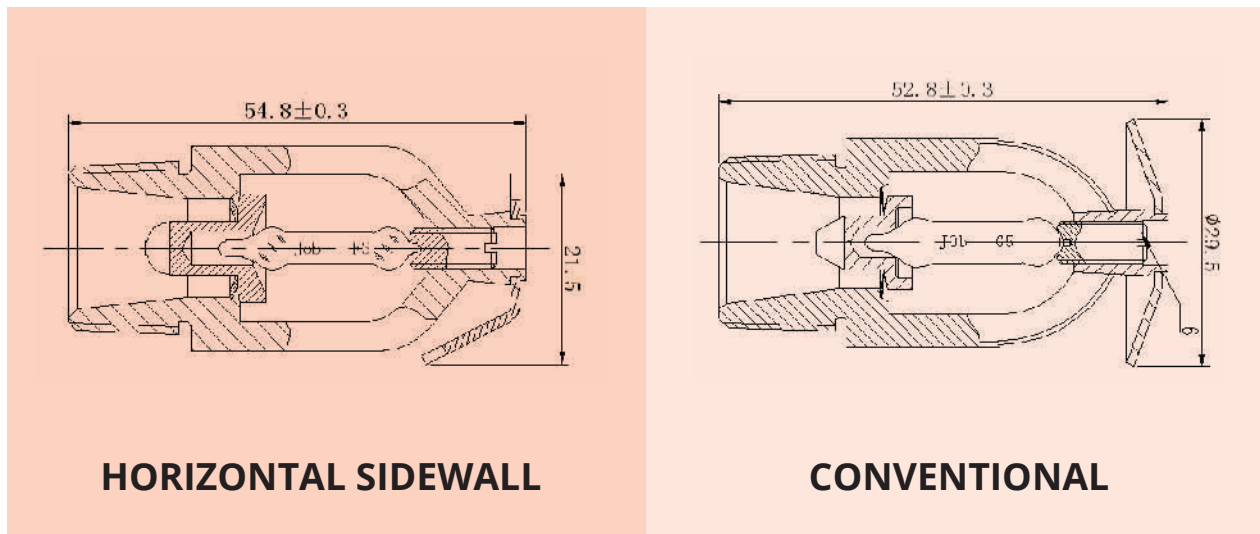

INSTALLATION

The sprinklers which are manufactured and tested in accordance with the rigid requirements of the Standard UL 199, also should be installed in accordance with the current Standard NFPA13. The system piping must be properly sized to insure the minimum required flow rate at the sprinkler. Check for the proper model, style, orifice size and temperature rating prior to installation, install sprinkler after the piping is in place to avoid mechanical damage, replace any damage units, wet pipe systems must be protected from freezing.

Upon completion of the installation, the system must be tested per recognized standard. In case of a thread leak, remove the unit, apply new pipe joint compound or tape and re-install.

INSTALLATION METHODS

- Pendent sprinkler must be mounted in a pendent position, and upright sprinkler must be mounted in upright position, the C U/P sprinkler may be mounted both in upright and pendent position, the horizontal sidewall sprinkler is install at horizontal position, to suit for field condition.
- Hand tighten the sprinkler into the sprinkler fitting. It is recommended that a torque of 7 ~14 ft lbs be used to obtain a thread 1/2 inch NPT Sprinkler joint. A radial force of 10 - 20 lbs.
- For using only a non-hardening pipe joint compound or Teflon tape apply to the male thread only.
- Hand tighten the sprinkler into fitting, use a 22mm open spanner or 8" (200mm) adjustable wrench on flat to tighten the unit into the fitting, do not use spanner on the frame arms, for it will cause the arms break and eases bulb burst.





PORTABLE FIRE EXTINGUISHERS



FIRE EXTINGUISHER

FIRE EXTINGUISHER MODEL NUMBER

Sr No	Model Number	Particulars
1.	FRNDB2	2KG ABC POWDER STORED PRESSURE, FIRE RATING 13A & 89B
2.	FRNDB4	4KG ABC POWDER STORED PRESSURE, FIRE RATING 27A & 183B
3.	FRNDB6	6KG ABC POWDER STORED PRESSURE, FIRE RATING 43A & 233B
4.	FRNDB9	9KG ABC POWDER STORED PRESSURE, FIRE RATING SSA & 233B
5.	FRNDB1	1KG ABC POWDER STORED PRESSURE, FIRE RATING 8A & SSB
6.	FRNDC1	1KG ABC POWDER (25%MAP), STORED PRESSURE, FIRE RATING SA & 34B
7.	FRNDC2	2KG ABC POWDER(25% MAP), STORED PRESURE FIRE RATING13A & 70B
8.	FRNDA6	6KG POWDER, STORED PRESSURE, FIRE RATING SSA& 233B
9.	FRNRA6	6KG POWDER, STORED PRESSURE, FIRE RATING SSA& 233B
10.	FRNRB6	6KG POWDER, STORED PRESSURE, FIRE RATING 43A& 233B
11.	FRNFB6	6Ltr FOAM STORED PRESSURE, FIRE RATING 27A & 183B
12.	FRNFC6	6Ltr FOAM STORED PRESSURE FIRE RATING 21A & 183B
13.	FRNFA9	9Ltr FOAM STORED PRESSURE FIRE RATING 34A &233B
14.	FRNFC9	9Ltr FOAM STORED PRESSURE FIRE RATING 27A & 233B
15.	FRNWA6	6Ltr WATER, STORED PRESSUER, FIRE RATING 13A
16.	FRNWB6	6Ltr WATER, STORED PRESSURE, FIRE RATING 34A
17.	FRNWA9	9Ltr WATER, STORED PRESSURE, FIRE RATING 21A
18.	FRNKA2	2Ltr WET CHEMICAL, STORED PRESSURE, FIRE RATING SA,70B & 25F
19.	FRNKA3	3Ltr WET CHEMICAL, STORED PRESSURE, FIRE RATING 13A,89B & 40F
20.	FRNKA6	6Ltr WET CHEMICALS, STORED PRESSURE, FIRE RATING 34A,233B & ?SF
21.	FRNCAS	5KG CARBON DIOXIDE, FIRE RATING 59B
22.	FRNCA2S	2KG CARBON DIOXIDE, FIRE RATIN 34B
23.	FRNCA2	2KG CARBON DIOXIDE FIRE RATING 34B
24.	FRNCASS	5KG CARBON DIOXIDE FIRE RATING 70B





CARBON DIOXIDE (CO₂) FIRE EXTINGUISHER

Product Data Sheet

Model	FRNCA2	FRNCA5	FRNCA2S	FRNCA5S
Capacity	2 KG	5 KG	2 KG	5 KG
Total Weight	7.2 KG	17.2 KG	7.2 KG	17.2 KG
Cylinder Height (mm)	515	665	515	665
Cylinder Diameter (mm)	114	152	114	152
Range of Throw	2.5	3.0	2.5	3.0
Fire Rating	34B	89B	34B	70B
Duration of Discharge (sec)	10	15	10	15
Extinguishing Agent	CO ₂	CO ₂	CO ₂	CO ₂
Propelling Agent	N ₂	N ₂	N ₂	N ₂
Operating Pressure	170 Bar	170 Bar	170 Bar	170 Bar
Material	Alloy	Alloy	Alloy	Alloy
Operating Temperature	-20C to +60C	-20C to +60C	-20C to +60C	-20C to +60C



DRY POWDER FIRE EXTINGUISHER

Product Data Sheet



Model	FRND B1	FRNDC 1	FRNDB 2	FRNDC 2	FRNDB 4	FRNDB 6	FRNDB 9	FRNDA 6	FRNRA 6	FRNRB 6
Capacity	1 KG	1 KG	2 KG	2 KG	4 KG	6 KG	9 KG	6 KG	6 KG	6 KG
Total Weight	1.98 KG	1.98 KG	3.6 KG	3.6 KG	6.1 KG	9.4 KG	13.1 KG	9.4 KG	9.4 KG	9.4 KG
Cylinder Height (mm)	315	315	391	391	483	494	556	494	494	494
Cylinder Diameter (mm)	91	91	110	110	130	163	183	163	163	163
Range of Throw	3.5	3.5	4.0	4.0	5.0	5.5	6.0	5.5	5.5	5.5
Fire Rating	8A & 55B	5A & 34B	13A & 89B	13A & 70B	27A & 183B	43A & 233B	55A & 233B	55A & 233B	55A & 233B	43A & 233B
Duration of Discharge (sec)	8	8	10	10	17	17	23	17	17	17
Extinguishing Agent	40% ABC Powder	40% ABC Powder	40% ABC Powder	40% ABC Powder	40% ABC Powder	40% ABC Powder	40% ABC Powder	40% ABC Powder	40% ABC Powder	40% ABC Powder
Propelling Agent	N ₂	N ₂	N ₂	N ₂	N ₂	N ₂	N ₂	N ₂	N ₂	N ₂
Working Pressure	14 Bar	14 Bar	14 Bar	14 Bar	14 Bar	14 Bar	14 Bar	14 Bar	14 Bar	14 Bar
Material	Steel Low Carbon	Steel Low Carbon	Steel Low Carbon	Steel Low Carbon	Steel Low Carbon	Steel Low Carbon	Steel Low Carbon	Steel Low Carbon	Steel Low Carbon	Steel Low Carbon
Operating Temperature	-30C to +60C	-30C to +60C	-30C to +60C	-30C to +60C	-30C to +60C	-30C to +60C	-30C to +60C	-30C to +60C	-30C to +60C	-30C to +60C



WATER FIRE EXTINGUISHER

Product Data Sheet



Model	FRNWA6	FRNWB6	FRNWA9
Capacity	6 LTR	6 LTR	9 LTR
Total Weight	9.8 KG	9.8 KG	13.5 KG
Cylinder Height(mm)	534	534	586
Cylinder Diameter(mm)	163	163	183
Range of Throw	5.0	5.0	7.0
Fire Rating	13A	34A	21A
Duration of Discharge (sec)	40	40	65
Extinguishing Agent	Water	Water	Water
Propelling Agent	N ₂	N ₂	N ₂
Operating Pressure	12 Bar	12 Bar	12 Bar
Material	Steel LowCarbon	Steel LowCarbon	Steel LowCarbon
Operating Temperature	-5C to +60C	-5C to +60C	-5C to +60C



WET CHEMICAL FIRE EXTINGUISHER

Product Data Sheet



Model	FRNKA2	FRNKA3	FRNKA6
Capacity	2 LTR	3 LTR	6 LTR
Total Weight	5.4 KG	5.4 KG	10.1 KG
Cylinder Height(mm)	428	428	534
Cylinder Diameter(mm)	130	130	163
Range of Throw	3.0	3.0	4.5
Fire Rating	5A, 70B & 25F	13A, 89B & 40F	34A, 223B & 75F
Duration of Discharge (sec)	13	15	30
Extinguishing Agent	50% WetChemical	50% WetChemical	50% WetChemical
Propelling Agent	N ₂	N ₂	N ₂
Operating Pressure	12 Bar	12 Bar	12 Bar
Material	Steel LowCarbon	Steel LowCarbon	Steel LowCarbon
Operating Temperature	-5C to +60C	-5C to +60C	-5C to +60C



SPECIAL SUPPRESSION SYSTEM



SP SERIES

HFC-227ea Fire Extinguishing System

The Frontier Fire Systems SP Series Clean Agent Fire Extinguishing System utilizes HFC-227ea as the extinguishing medium. HFC-227ea is a colorless, non-toxic gas perfectly suited to protect high value assets in areas that may be normally occupied, in locations where clean up of other agents is problematic, when storage space for a fire suppression agent is restricted, or when an electrically non-conductive agent is required. Each system consists of the following components and their associated accessories:

- 1 HFC-227ea Storage Components** - Storage components consist of the cylinder assembly (s), which contains the HFC-227ea chemical agent, and the cylinder bracket(s), which holds the cylinder assembly securely in place.
- 2 HFC-227ea Distribution Components** - Distribution components consist of the discharge nozzles used to introduce the HFC-227ea agent into a protected hazard along with the associated piping system used to connect the nozzles to the cylinder assembly.
- 3 Trim Components** - Trim components complete the installation of the HFC-227ea system and consist of connection fittings, pressure gauge, lowpressure supervisory switch, electric valve actuator, and manual valve actuator.
- 4 Slave Arrangement Components** - Slave arrangement components consist of the pneumatic valve actuator(s), actuation check valve, bleed valve, pilot hose, and fittings required for a multiple cylinder (slave) arrangement manual valve actuator.
- 5 Supplemental Components** - Supplemental components include the discharge pressure switch and manifold check valve. They supplement the core equipment or complete a specific multicylinder configuration.
- 6 Control Panel** - This device monitors the condition of the electric actuator, detectors, warning devices, cylinder pressure, and any manual release and abort stations. All electric or electronic devices must connect to the control panel in order to function.

Typical Clean Agent System Layout

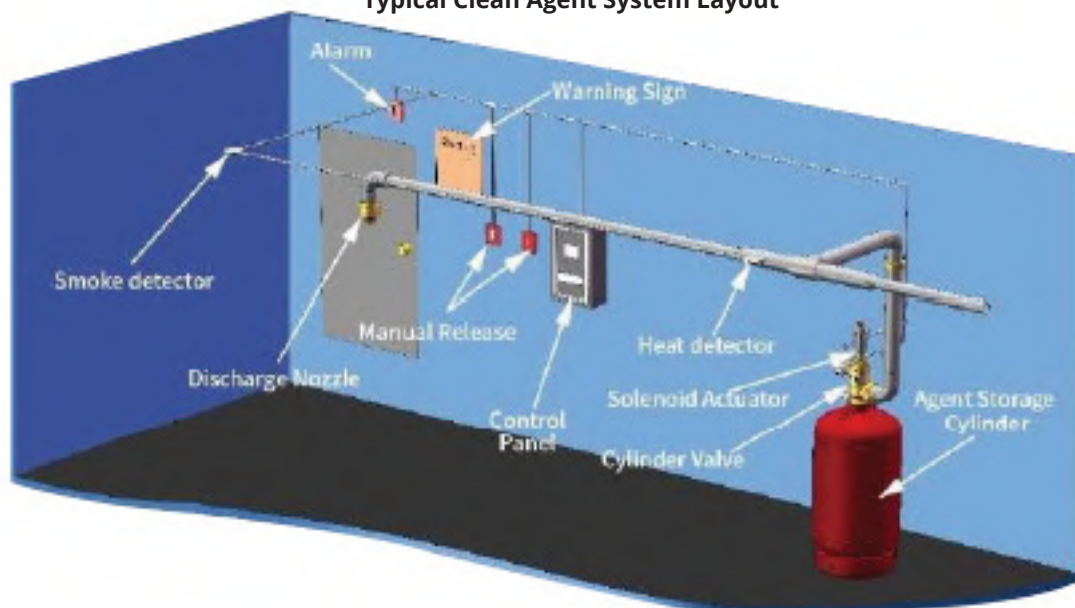

EQUIPMENT DESCRIPTION

The HFC-227ea agent is stored as a liquid in cylinder assemblies designed specifically for the application and charged to a fill density of between 480 kg/m³ and 1121 kg/m³. To ensure optimal performance, each cylinder is superpressurized with dry nitrogen to 25 or 42 bar at 21°C. An identification label is affixed to the cylinder body indicating the fill quantity of HFC-227ea, charging pressure, date of fill, and fill station. The SP Series supports three cylinder capacities.

HFC-227ea fire extinguishing systems are designed to be discharged within 10 seconds into a room, area, or enclosure with the structural integrity to retain the agent. The HFC-227ea uniformly mixes throughout the protected area, achieving a minimum concentration level in accordance with NFPA 2001 and/or agency listings.

Cylinder with Valve Assembly Part No.	Nominal Working Pressure (bar)	Nominal Cylinder Volume (L)	Fill Capacity(kg)		Outlet size (mm)	Empty Weight (kg)
			Min.	Max.		
811.101.0156	25	40	19.2	44.8	49	52
811.101.0158	42					
811.101.0166	25	50	24.0	56.0	49	57
811.101.0168	42					
811.101.0176	25	60	28.8	67.2	49	68
811.101.0178	42					
811.101.0186	25	70	33.6	78.4	49	67
811.101.0188	42					
811.101.0196	25	80	38.4	89.6	49	72
811.101.0198	42					
811.101.0206	25	90	43.2	100.8	49	84
811.101.0208	42					
811.101.0216	25	100	48.0	112.0	49	89
811.101.0218	42					
811.101.0226	25	120	57.6	134.4	49	99
811.101.0228	42					
811.101.0236	25	150	72.0	168.0	49	114
811.101.0238	42					
811.101.0246	25	180	86.4	201.6	49	146
811.101.0248	42					
811.101.0155	25	40	19.2	44.8	33	50
811.101.0157	42					
811.101.0165	25	50	24.0	56.0	33	55
811.101.0167	42					
811.101.0165	25	60	28.8	67.2	33	60
811.101.0167	42					



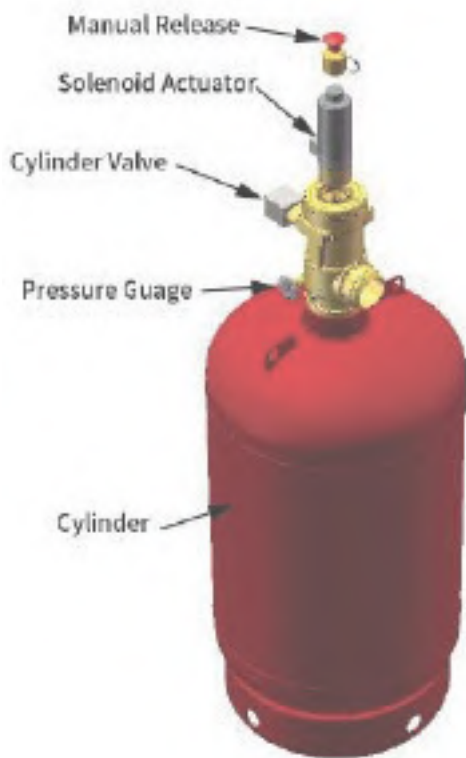

The cylinder assembly is composed of a cylinder, dip tube, cylinder valve, safety release.

Cylinder Valve: The automatic release of HFC- 227ea is controlled by a forged brass, differential pressure operated cylinder valve connected to the neck of the cylinder. The valve assembly is shipped with an anti- recoil safety device installed in the discharge outlet and chained to the cylinder valve.

Dip Tube: A threaded, rigid dip tube extends from the cylinder neck down to its bottom.

Cylinder: The light walled, welded seam cylinder is manufactured according to the requirements of TPED. Internal neck threads allow connection of the cylinder valve. The cylinder is designed for mounting in a vertical position only.

The cylinder valve has five connection points:

Valve Actuation Connection: A threaded connection located on top of the cylinder valve serves as the attachment point for the electric (primary) or pneumatic (slave) valve actuator.

Pressure Gauge Connection: A female connection serves as the attachment point for the pressure gauge. It is fitted with an internal check valve to allow removal of the gauge while the cylinder is pressurized.

Discharge Outlet: A 1.25 in (33mm) or 2 in (49mm) male thread connection serves as the attachment point for discharge piping.

Pilot Actuation Port: A 1/4 in (8 mm) FNPT connection (shipped with a removable plug) provides a means of applying actuation pressure to the slave cylinder(s). This can also be used for attachment of the discharge pressure switch in single cylinder arrangements. The port is pressurized only during the 10 second discharge period.



FOAM SYSTEM BLADDER TANK

BLADDER TANK - 100 LITERS TO 1000 LITERS

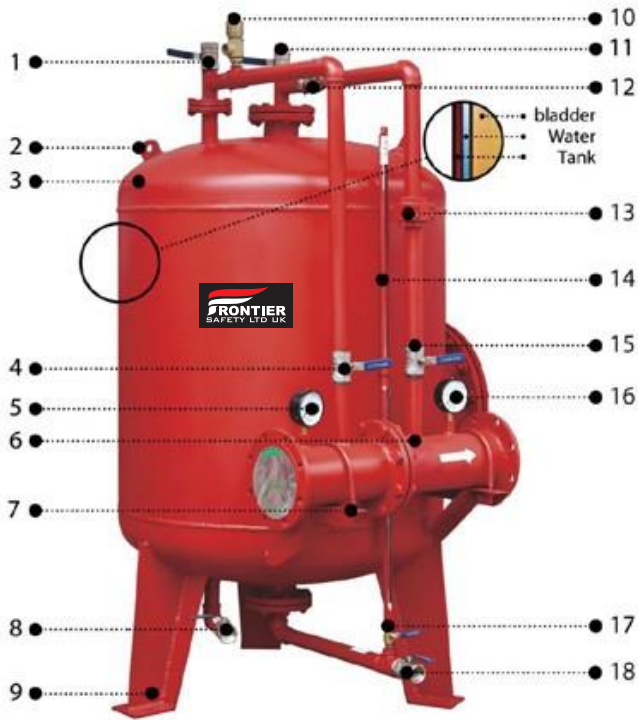

FUNTION

The bladder tank is a carbon steel pressure vessel containing an elastomeric separation bladder between the water and foam concentrate. The bladder permits water pressure to be transferred to the foam concentrate with- out the two fluids mixing together. A ratio controller generates a water pressure drop by means of a reduced cross section where the water stream passes through it. As the foam concentrate pressure is higher than the pres- sure at the ratio controller, the foam starts flowing towards the water and mixing at a calibrated rate, which is dependant on the water flow rate.

APPLICATION

Foam bladder tank, together with ratio controllers, form a balanced pressure proportioning system used to mix water and fire fighting foam together to generate an effective extinguishing medium.

The bladder tank technology is a mixing method allows the water/foam ratio to remain stable by automatically adjusting to the variable flow rates and pressure conditions that may occur during system operation. This feature makes bladder tanks particularly suitable for multiple hazard systems, sprinkler systems and any other system operating under variable, non predictable, flow and pressure conditions.

SPECIFICATION

- 1 Water Vent Valve
- 2 Lifting Lug
- 3 Tank
- 4 Water Shut-Off Valve
- 5 Water Inlet Pressure Gauge
- 6 Ratio Controller
- 7 Ratio Controller Fixed Bracket
- 8 Water Drain Valve
- 9 Earth Lug
- 10 Relief Valve
- 11 Foam Vent Valve
- 12 Foam Check Valve
- 13 Concentrate Control Valve
- 14 Analog Level Indicator
- 15 Foam Contentrate Shut-Off Valve
- 16 Water/Foam Mixture Outlet Gauge
- 17 Foam Level Indicator Valve
- 18 Foam Concentrate Drain/Fill Valve



AQUEOUS FILM FORMING FOAM

- Quickest surface sealing and flame knockdown by blocking oxygen supply to the fuel.
- Superior burn back resistance.
- Environment friendly.
- Based on the latest C6 chemistry.

TYPES

AFFF 1 (AFFF 1%) 1 volumes of concentrate with 99 volumes of water (1% Induction Rate)

AFFF 3 (AFFF 3%) 3 volumes of concentrate with 97 volumes of water (3% Induction Rate)

AFFF 6 (AFFF 6%) 6 volumes of concentrate with 94 volumes of water (6% Induction Rate)

PRODUCT DESCRIPTION

AFFF is a nontoxic foam concentrate in the form of a clear liquid with no stratification or turbidity. It has the most advanced foam formulation in low and medium expansion foam for effective extinguishment of Class A and B fires. It gives excellent penetration qualities as a wetting agent when used on Class A fires. Rigorous quality control standards are maintained while producing AFFF. It is specially formulated to make sure that the product is reliable for its ultimate fire management performance. AFFF consists of effective surfactants so as to have superior knockdown properties on all water immiscible fuel fires at a very low application rate.

FIRE-FIGHTING PROCESS

AFFF forms a vapour-sealing aqueous film on the surface of hydrocarbon fuel so that the flammable vapours are fully suppressed with a very thin layer of foam blanket. The exceptional self-sealing property re-seals any disturbed or broken surface of burning liquid. The fire will be further suppressed with the cooling effect of the water content in the foam.

COMPATIBILITY

AFFF is proved to be compatible with a wide range of conventional foams including protein-based products and hence can be applied as a twin-agent system with other types of foams and dry chemical powders. AFFF can be used with standard, conventional low/medium expansion foam making equipment with fresh/sea/brackish water, either as a premixed solution or through foam induction systems. It is not suitable for use on polar fuels with appreciable water solubility, such as methyl and ethyl alcohol, acetone, and methyl ethyl ketone.

APPLICATIONS

- High risk situations where Class B hydrocarbons such as crude oil, diesel, gasoline and aviation kerosene with low water solubility are stored, processed, or transported. (E.g. Refineries & Petrochemicals Plants)
- Crash Tenders/Rapid Intervention Vehicles (RIV)/ Monitors/Portable Foam Extinguishers etc.
- Stores, ware-houses, tanker loading areas and other local risk involving a spilled fuel fire.
- Tank farms, Power Plants. Steel Plants.
- Subsurface injection including hose-reel installations, flammable liquid tank fires.
- Fire suppression systems at Airforce base. Airports, Sea Airports and Navy ships and docks.
- Fire Extinguisher Manufacturers.
- Deep-seated fires in Jute, Cotton, Wood, Coal, Rubber, Plastics and similar materials.

STORAGE

AFFF has been formulated by world class preservatives such as Acid- Alkaline buffer and other foam stabilizer to give a very long storage life. A shelf -life of at least ten years can be expected if it is stored properly in original containers at recommended temperatures and atmospheric condition.



AQUEOUS FILM FORMING FOAM

SPECIFICATION

Property	AFFF 1%	AFFF 3%	AFFF 6%
Appearance	Amber Colour	Amber Colour	Amber Colour
pH@20°C	6.5-8.5	6.5-8.5	6.5-8.5
Sp gravity@20°C	1.00, min	1.00, min	1.00, min
Miscibility Distilled water Synthetic Sea Water	Miscible Miscible	Miscible Miscible	Miscible Miscible
Surface Tension (dyn/cm)	Less than 18	Less than 18	Less than 18
Spreading Coefficient	More than 3	More than 3	More than 3
*Lowest use Temperature	0°C	0°C	0°C
Pour Point	Freely move at 0°C or below		
Viscosity @20°C	Max 20cst	Max 20cst	Max 20cst
Sediment	Less than 0.25% (Original) Less than 0.50% (Ageing)		
Freezing and Thawing (Sedimentation fiction) No Sedimentation / Stratification after freezing and Thawing at (-) 5°C to 60°C	No Sedimentation / Stratification after freezing and Thawing at (-) 0°C to 60°C		
**Expansion Ratio	6.00 to 10.00	6.00 to 10.00	6.00 to 10.00
**Drainage (25%)	Min 90sec	Min 90sec	Min 90sec

For extreme sub-zero conditions, AFFF can be specially formulated where a concentrate is required to be 'freeze protected' to minus 30°C or even less.

* Also available in freeze protected type

**Value depends on equipment used and system parameters



UL LISTED MEDIUM VELOCITY WATER SPRAY NOZZLE

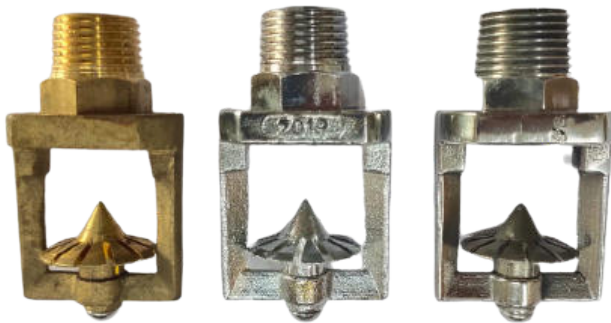

TECHNICAL DATA

MODEL	FRN-MVN-B (Brass Material) FRN-MVN-S (Stainless Steel 316 Material)
TYPE	FRN-MVN-B & FRN-MVN-S are without strainer. Optional strainers are available on request
MAXIMUM WORKING PRESSURE	12 Bar (175 PSI)
END CONNECTION	½" NPT (½" BSPT OPTIONAL)
MATERIAL	Refer Table-I
WATER SPRAY ANGLE FOR EACH K-FACTOR	140°, 120° (UL Listed), 160°, 110°, 100°, 90°, 80° & 65°
K FACTOR	FRN-MVN-B & FRN-MVN-S Metric (US) K-18 (1.26) K-22 (1.54) K-30 (2.10) K-35 (2.45) K-41 (2.87) K-51 (3.57) K-64 (4.48) K-79 (5.53) K-102 (7.14) Other K-Factors are available onrequest.
FINISH	FRN-MVN-B: Natural Brass finish/ Nickel-Chrome plated/ Electroless Nickel plated, FRN-MVN-S:Natural finish
APPROVALS	UL Listed For Approval data refer UL Listing certificate
ORDERING INFORMATION	Specify K-Factor, spray angle, finish, model and end connection

DESCRIPTION

The Medium Velocity Water Spray Nozzles are open type (non-automatic) nozzles, designed for directional spray application in fixed fire protection system.

Medium velocity water spray nozzle has a deflector, which discharges water in a directional cone shaped pattern of small droplet size. The water is uniformly distributed over the surface to be protected.

FRONTIER Nozzles are effectively designed to apply water to exposed vertical, horizontal, curved and irregular shaped surfaces to allow cooling to prevent excessive absorption of heat from external fire and avoid structural damage or spread of fire. In some application nozzles may be installed to control or extinguish the fire depending on water design density as per applicable codes. The nozzle is used in deluge water spray system for special hazard fire protection application.

As the design and intent of specific water spray system may vary considerably, MV nozzle is made available in several combinations of orifice sizes (K-factors) and spray angles.

The minimum desirable pressure to achieve a reasonable spray pattern is 1.4 Kg./Sq.cm. The water distribution pattern as shown in the graph in following pages is at an average pressure of 2.0 Kg./Sq.cm. The change in pressure between 1.4 to 3.5 Kg./sq.cm. does not affect considerable change in spray angle.

The spray pattern shown is with indoor application. System designer must consider wind velocity while designing the system for outdoor application. Field obstruction if any affecting the spray pattern of the nozzle must also be considered. The nozzle may be oriented to any position as deemed necessary to cover the hazard.





DELUGE VALVE

VALVE OPERATION

Deluge valve is a quick release, hydraulically operated diaphragm valve. It has three chambers, isolated from each other by the diaphragm operated clapper and seat seal. While in 'SET' position, water pressure is transmitted through an external bypass check valve and restriction orifice from the system supply side to the top chamber, so that supply pressure in the top chamber acts across the diaphragm operated clapper which holds the seat against the inlet supply pressure because of differential pressure design.

On detection of fire the top chamber is vented to atmosphere through the outlet port via opened actuation device(s). The top chamber pressure cannot be replenished through the restricted inlet port, thus it reaches less than half the supply pressure instantaneously and the upward force of the supply pressure lifts the clapper allowing water to enter the system piping network and alarm devices.

DESCRIPTION

Deluge Valve is known as a system control valve in a deluge system, used for fast application of water in a spray system. Deluge valve protects areas such as power transformer installation, storage tank, conveyor protection and other industrial application etc. With the addition of foaming agent deluge valve can be used to protect aircraft hangar and inflammable liquid fire.

TECHNICAL DATA

NOMINAL SIZE	200, 150, 100, 80 & 50NB
MATERIAL	Cast Iron
MAXIMUM SERVICE PRESSURE	12 Bar (175 PSI)
THREADED OPENING	BSPT
MOUNTING	90° pattern inlet to outlet vertical mounting
FACTORY HYDROSTATIC TEST PRESSURE	25 Kg./sq.cm. (350 PSI)
FLANGE CONNECTION	ANSI B 16.1 FF # 125 (Flange drilling matching to ANSI B 16.5 # 150)
TRIM	Galvanized Steel with Brass Valves
WET PILOT SPRINKLER HEIGHT LIMITATION	As per graph in the catalogue
NET WEIGHT WITHOUT TRIM	200NB - 214 Kg 150NB - 131 Kg 100NB - 77 Kg 80NB - 50 Kg 50NB - 47 Kg
FINISH	Red RAL 3000
ORDERING INFORMATION	Specify 1) Size of valve 2) Trim type - Dry Pilot Wet Pilot Electric Release Test & Alarm



PRE-ACTION SYSTEM



GENERAL DESCRIPTION

Pre-action sprinkler systems are specialized for use in locations where accidental water discharge is undesired and pre-alarm fire condition required to allow time for alternate fire suppression means, such as in museums with rare art works, manuscripts or books, libraries, archives, Data Centers, Lift Machine room, storage areas for valuable artifacts, computer and electronic equipments.

The supervised Single interlock Pre-action system with Electric Actuation utilizes automatic sprinklers and a supplemental detection system. Detection system consists of pre-action control panel, heat / smoke / multisensor, manual release station, etc. The release (Detection) system shall be designed to operate prior to sprinkler operation.

The followings are the main advantages of a single interlock pre-action system over wet pipe system.

- 1) Pre-alarm fire condition will occur prior to the sprinkler operation which allows extinguishing the fire by alternate fire suppression means. (Handheld fire extinguisher etc.,)
- 2) Integrity of the sprinkler piping can be monitored by a supervisory low pressure alarm switch. A trouble annunciator signal will occur whenever any abnormal leakage or accidental damage occurs in the piping system. However no water will flow and the air pressure is for supervisory alarm only.
- 3) In the event of a fire the delay of water delivery time will be avoided because the detection system is designed to operate prior to sprinkler operation and allowing water to flow into the piping.

PRE-ACTION SYSTEM

In supervised single interlock pre-action system air is introduced into the system piping at a pressure of approximately 10 psi from an air or nitrogen source such as:

- 1) An air compressor
- 2) A plant air system (owner's air)
- 3) Nitrogen Cylinder Gas Supply

Any of the above sources can be used to fill the required system pressure in 30 minutes. Suitable automatic air maintenance device is used to control the pressure in the pre-action system. This air pressure supervises the piping to detect leaks. The pressure switch is used for detection of low air pressure on the sprinkler pipe.

A riser check valve in the single interlock system provides air check to the system and pressurized with a nominal supervisory air pressure of 10 Psi. The supervisory low pressure alarm switch is set to transfer its contacts at 5 Psi to the pre-action control panel which in turn gives trouble signal.

If any of the detectors senses fire, operation of manual release station will give signal to pre-action control panel to energize (activate) the solenoid valve. Energized solenoid valve will drain the water from the top chamber of the deluge valve and allowing water to flow into the piping. The flow of water converts the dry system into a wet system. When the fire produces enough heat to operate one or more sprinkler heads, water will flow from the operated sprinkler heads and control or suppress the fire.

UL Listed Deluge valve is a quick release, hydraulically operated diaphragm actuated type of valve. It has three chambers, isolated from each other by the diaphragm operated clapper and seat seal. While in SET position, water pressure is transmitted through an external bypass check valve and hydraulic shut-off valve from the system supply side to the top chamber, so that supply pressure in the top chamber act across the diaphragm operated clapper which holds the seat against the inlet supply pressure because of the 2 : 1 differential pressure design. On detection of fire the top chamber is vented to atmosphere through the outlet port via opened actuation devices (solenoid valve). If the top chamber pressure reaches less than half the supply pressure instantaneously, the upward force of the supply pressure lifts the clapper allowing water to enter the system piping network and alarm devices. As water flows into the system, the hydraulic shut-off valve becomes pressurized and automatically shuts off the top chamber supply flow (Priming line). Shutting off the top chamber supply flow prevents the **Pre-action valve** from becoming re-pressurized, thereby preventing inadvertent closing of the pre-action valve during a fire (If the solenoid valve become de-energized after its initial operation).

Technical Data:

Nominal Size : 50, 80, 100, 150 & 200

Working Pressure : 175 psi



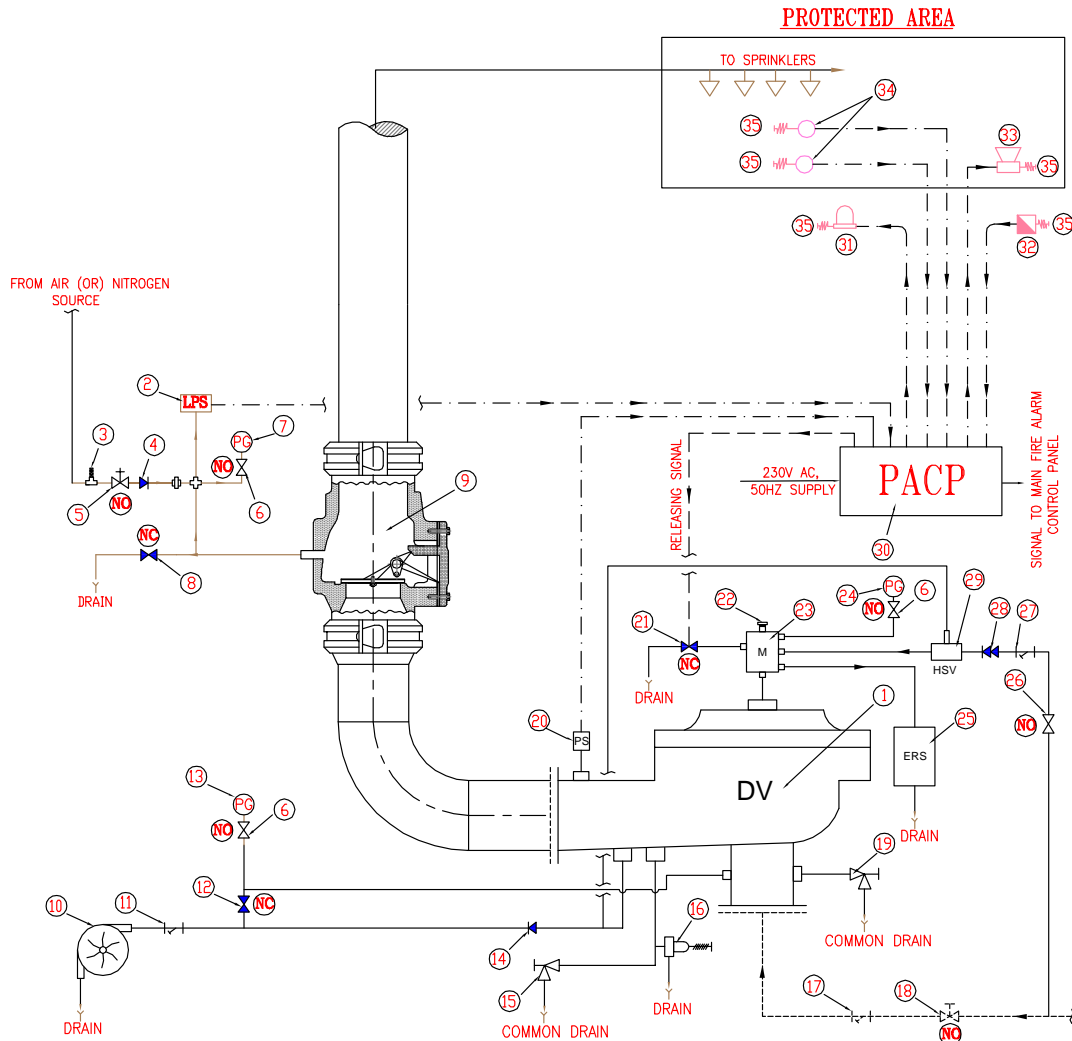

SCHEMATIC DIAGRAM FOR SUPERVISED SINGLE INTERLOCK PRE-ACTION SYSTEM (ELECTRIC ACTUATION)

LEGENDS

- | | |
|-----------------------------------|--|
| ① DELUGE VALVE | ⑳ WATER FLOW ALARM PRESSURE SWITCH |
| ② LOW AIR PRESSURE ALARM SWITCH | ㉑ SOLENOID VALVE |
| ③ PRESSURE RELIEF VALVE | ㉒ PLUG |
| ④ CHECK VALVE (AIR) | ㉓ 6-WAY MANIFOLD |
| ⑤ SYSTEM AIR SUPPLY VALVE (GLOBE) | ㉔ TOP CHAMBER PRESSURE GAUGE (DIAPHRAGM) |
| ⑥ BALL VALVE | ㉕ EMERGENCY RELEASE STATION |
| ⑦ PRESSURE GAUGE (AIR SUPPLY) | ㉖ PRIMING BALL VALVE |
| ⑧ SYSTEM MAIN DRAIN VALVE | ㉗ STAINER (PRIMING) |
| ⑨ RISER CHECK VALVE | ㉘ RESTRICTION CHECK VALVE |
| ⑩ WATER MOTOR ALARM GONG | ㉙ HYDRAULIC SHUT-OFF VALVE |
| ⑪ STAINER (ALARM GONG) | ㉚ PRE ACTION CONTROL PANEL |
| ⑫ BALL VALVE (ALARM TEST) | ㉛ STROBE LIGHT |
| ⑬ PRESSURE GAUGE (WATER SUPPLY) | ㉜ MANUAL RELEASE |
| ⑭ CHECK VALVE | ㉝ STROBE HORN |
| ⑮ ANGLE DRAIN VALVE | ㉞ DETECTOR |
| ⑯ DRIP VALVE | ㉟ END OF LINE |
| ⑰ STAINER | Ⓝ NO NORMALLY OPEN |
| ⑱ SYSTEM CONTROL VALVE | Ⓞ NORMALLY CLOSED |
| ⑲ ANGLE VALVE (MAIN DRAIN) | |





VALVES



VALVE

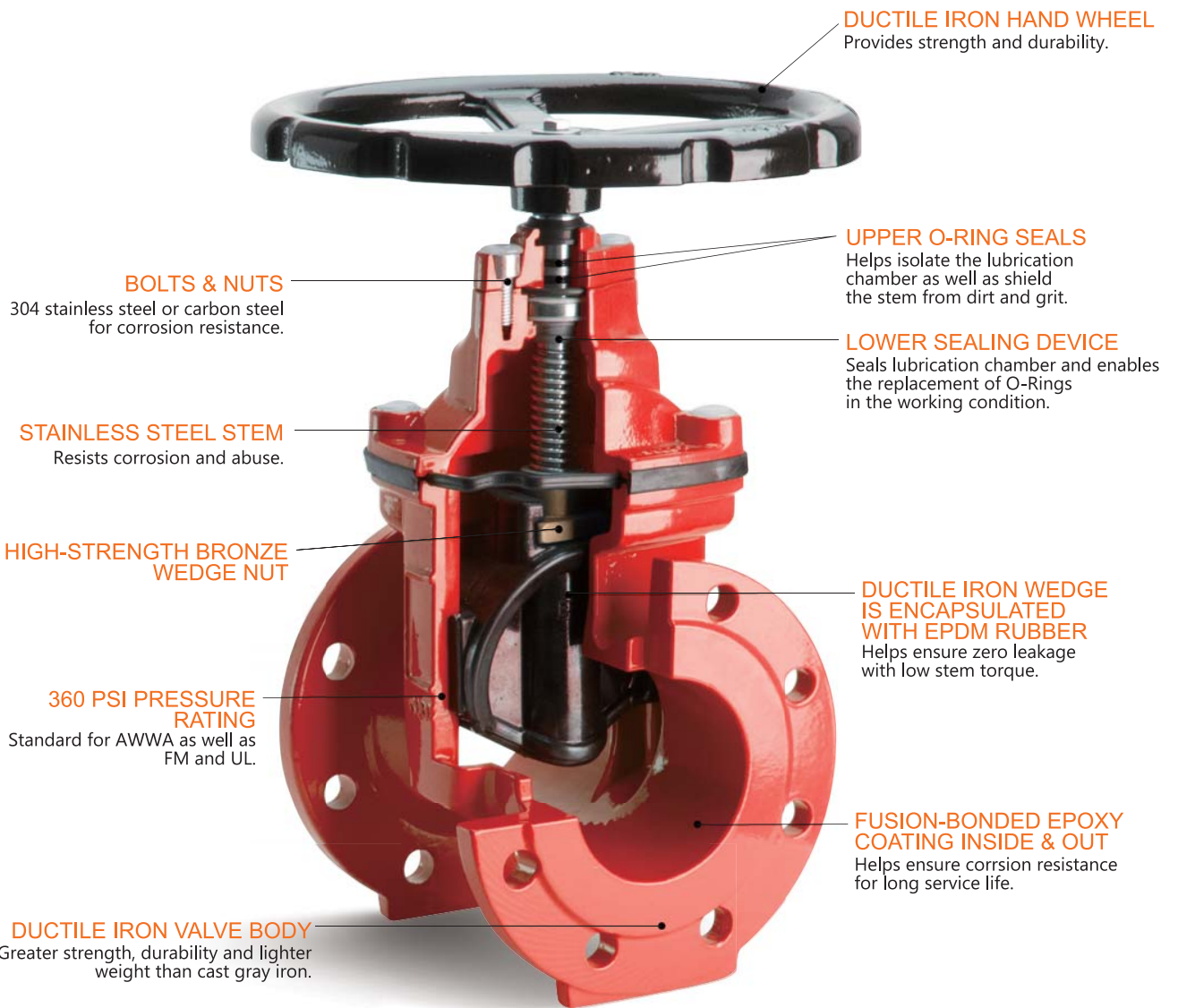



1

DIN F4 Resilient seated NRS gate valve-flange end



2

BS5163 Resilient seated NRS gate valve-flange end



3

AWWA C515 Resilient seated NRS gate valve-flange end



4

AWWA C515 Resilient seated NRS gate valve-flange end with indicator post flange



5

Resilient seated NRS gate valve grooved end



6

DIN F4 Resilient seated OS&Y gate valve-flange end



7

BS5163 Resilient seated OS&Y gate valve-flange end



8

AWWA C515 Resilient seated OS&Y gate valve-flange end



9

Resilient seated OS&Y gate valve-grooved end



10

Butterfly valve with tamper switch wafer style



11

Butterfly valve with lever handle wafer style



12

Butterfly valve with tamper switch grooved end





13

Butterfly valve with lever handle grooved end



14

Swing check valve with flange end



15

Swing check valve with grooved end



16

Y strainer with flange end



17

Y strainer with grooved end



18

Deluge Valve



19

Alarm Check Valve



20

Pressure Reducing Valve



21

Wet Barrel Hydrant





**FRONTIER IS**
SERVING WORLDWIDE



Distinctive Frontier Company for safety Equipment L.L.C

Headoffice: Riyadh - Almanakh Area 18th Exit.
Eastern Province:
8561 King Abdulaziz Road 2821 North Khobar Area
PO.Box 34426 Al Khobar City - KSA

more information:

Mobile: 966 54 147 4609
e-mail: info@frontierksa.com
www.frontierksa.com

